

2008

A feasibility study of implementing an Ammonia Economy

Jeffrey Ralph Bartels
Iowa State University

Follow this and additional works at: <http://lib.dr.iastate.edu/etd>

 Part of the [Mechanical Engineering Commons](#)

Recommended Citation

Bartels, Jeffrey Ralph, "A feasibility study of implementing an Ammonia Economy" (2008). *Graduate Theses and Dissertations*. 11132.
<http://lib.dr.iastate.edu/etd/11132>

This Thesis is brought to you for free and open access by the Graduate College at Iowa State University Digital Repository. It has been accepted for inclusion in Graduate Theses and Dissertations by an authorized administrator of Iowa State University Digital Repository. For more information, please contact digirep@iastate.edu.

A feasibility study of implementing an Ammonia Economy

By

Jeffrey Ralph Bartels

A thesis submitted to the graduate faculty
in partial fulfillment of the requirements for the degree of
MASTER OF SCIENCE

Major: Mechanical Engineering

Program of Study Committee:
Michael B. Pate, Co-Major Professor
Ron M. Nelson, Co-Major Professor
Gap-Yong Kim

Iowa State University

Ames, Iowa

2008

Copyright © Jeffrey Ralph Bartels, 2008. All rights reserved.

TABLE OF CONTENTS

LIST OF FIGURES	iv
LIST OF TABLES	v
ABSTRACT	vi
CHAPTER 1. OVERVIEW OF AN AMMONIA ECONOMY.....	1
CHAPTER 2. HYDROGEN PRODUCTION	4
2.1 Fossil Fuel Based Hydrogen Sources	4
2.1.1 Converting Fossil Fuel to Hydrogen.....	4
2.1.2 Hydrogen from Natural Gas.....	5
2.1.3 Hydrogen from Coal Gasification.....	7
2.2 Alternative Energy Based Hydrogen Sources	11
2.2.1 Converting Alternative Energy Sources to Hydrogen	11
2.2.2 Hydrogen from Nuclear Energy.....	12
2.2.3 Hydrogen from Solar Energy.....	15
2.2.4 Hydrogen from Wind Energy	20
2.2.5 Hydrogen from Biomass	23
2.3 Cost of Hydrogen from Conventional and Alternative Energy Sources	27
2.4 Summary.....	33
CHAPTER 3. AMMONIA PRODUCTION.....	34
3.1 Ammonia Synthesis Processes.....	35
3.1.1 Haber-Bosch Ammonia Synthesis	35
3.1.2 Thermochemical Ammonia Synthesis	37
3.1.3 Solid State Ammonia Synthesis.....	37
3.2 Fossil Fuel Based Ammonia Synthesis Processes	37
3.2.1 Ammonia from Natural Gas.....	38
3.2.2 Ammonia from Coal	40
3.3 Alternative Energy Based Ammonia Synthesis Processes	41
3.3.1 Ammonia from Wind Energy	42
3.3.2 Ammonia from Ocean Thermal Energy Conversion	42
3.4 Ammonia Production from Hydrogen	44
3.4.1 Ammonia Synthesis System Components	45
3.4.2 Ammonia Synthesis from an Energy Source	46
3.4.3 Ammonia Synthesis from a Hydrogen Source.....	47
3.4.4 Cost of Ammonia from Conventional and Alternative Energy Sources.....	53
3.4.5 Comparison to Fossil Fuels.....	56
3.4.6 Sensitivity Analysis	58
3.5 Summary.....	61
CHAPTER 4. LARGE-SCALE STORAGE OF ALTERNATIVE FUELS	62
4.1 Pressure Storage.....	62
4.1.1 Ammonia Pressure Storage.....	62
4.1.2 Hydrogen Pressure Storage.....	63
4.2 Low-Temperature Storage	63

4.2.1 Ammonia Low-Temperature Storage	63
4.2.2 Hydrogen Low-Temperature Storage	64
4.3 Low-Temperature Storage Analysis	64
4.3.1 Key Parameters and Assumptions.....	65
4.3.2 Analysis Results.....	67
4.3.3 Low-Temperature Storage System Costs.....	70
4.4 Summary.....	71
CHAPTER 5. TRANSPORTATION OF ALTERNATIVE FUELS	73
5.1 Fuel Transportation with Storage Vessels	73
5.1.1 Ammonia Fuel Transportation with Storage Vessels	74
5.1.2 Hydrogen Fuel Transportation with Storage Vessels	74
5.1.3 Summary of Storage Vessel Transport	75
5.2 Pipeline Fuel Transportation.....	75
5.2.1 Ammonia Pipeline Transport.....	76
5.2.2 Hydrogen Pipeline Transport.....	76
5.3 Pipeline Analysis	77
5.3.1 Key Parameters and Assumptions.....	77
5.3.2 Analysis Results.....	81
5.3.3 Pipeline System Costs.....	88
5.4 Summary.....	89
CHAPTER 6. AN ECONOMIC COMPARISON BETWEEN AMMONIA AND HYDROGEN TRANSPORTATION FUELS	91
6.1 Comparing Hydrogen and Ammonia Costs.....	91
6.2 Alternative Energy Sources of Ammonia.....	92
6.3 Total Estimated Production, Storage, and Transportation Cost.....	92
6.4 Existing Infrastructure for an Ammonia Economy.....	94
6.5 Summary.....	94
CHAPTER 7. CONCLUSIONS	95
BIBLIOGRAPHY.....	97
ACKNOWLEDGEMENTS.....	103

LIST OF FIGURES

Figure 1: World natural gas reserves by country [4]	6
Figure 2: World coal reserves by country [4]	8
Figure 3: Sulphur-iodine thermochemical process shown by Richards et al. [19]	14
Figure 4: Flow diagram of Haber-Bosch synthesis loop showing major components	36
Figure 5: Haber-Bosch ammonia synthesis with natural gas	39
Figure 6: Diagram of methods to produce ammonia from an several energy sources	46
Figure 7: Ammonia production from a hydrogen source	48
Figure 8: Sensitivity analysis of ammonia selling price	60
Figure 9: Diagram of ammonia storage vessel and refrigeration system [64]	66
Figure 10: Hydrogen and ammonia low-temperature storage system diagram	68
Figure 11: Ammonia pipelines in the United States [72]	76
Figure 12: Diagram of the ammonia pipeline system	80
Figure 13: Diagram of hydrogen pipeline system	81
Figure 14: Hydrogen and ammonia pipeline system diagram	83
Figure 15: Ammonia pipeline system with conversion to hydrogen	84
Figure 16: Diagram of methane and ammonia pipeline system	85
Figure 17: Total cost for hydrogen and ammonia production, storage, and transport	93

LIST OF TABLES

Table 1: Financial assumptions for Gray and Tomlinson study [3, 5]	9
Table 2: Summary of Gray and Tomlinson study results for several coal gasification technologies [5]	9
Table 3: Financial assumptions for Kreutz et al. study [11]	10
Table 4: Summary of Kreutz et al. study results for several coal gasification technologies [11]	11
Table 5: Summary of hydrogen production cost from wind energy by Levene et al. [30]	22
Table 6: Hydrogen production studies summary	28
Table 7: Hydrogen production studies adjusted for inflation	30
Table 8: Conversion efficiency from hydrogen to ammonia	50
Table 9: Economic assumptions for ammonia synthesis facility	52
Table 10: Specific capital cost for ammonia synthesis for designs with and without ASU and gas turbine for a 2,200 t/day synthesis plant	52
Table 11: Specific capital cost per tonne of ammonia and total plant cost based on plant size and use of ASU	53
Table 12: Calculated cost of ammonia from hydrogen sources	54
Table 13: Comparison of alternative fuel costs in 2007 dollars	57
Table 14: Sensitivity analysis results	59
Table 15: Comparison between hydrogen and ammonia low-temperature storage	68
Table 16: Comparison of storage vessel transport methods for ammonia and hydrogen	75
Table 17: Comparison between hydrogen and ammonia pipeline system	82
Table 18: Energy use in the methane and ammonia pipeline systems	86
Table 19: Pipeline analysis results	87
Table 20: Production, storage, and transportation cost for hydrogen and ammonia	93

ABSTRACT

This thesis reports the results of a feasibility study performed on the concept of an Ammonia Economy, which treats ammonia as an alternative fuel and energy storage mechanism. As part of the Ammonia Economy, costs for production, storage, and transportation of this alternative fuel are also presented. The cost of hydrogen, which is the main feedstock for ammonia production, was first determined for both fossil-fuel and alternative energy sources. Capital costs and operating parameters of an ammonia synthesis plant were then used in an economic model to calculate the cost of ammonia from energy sources that included natural gas, coal, nuclear, ocean thermal energy conversion (OTEC), wind, solar, and biomass. The energy use and cost for both hydrogen and ammonia fuels was then compared for fuel storage and transportation.

The results showed that the lowest cost ammonia source is coal with a production cost of 147-432 \$/t, or a gasoline equivalent of 0.96-2.83 \$/gal. Natural gas and OTEC also provided low costs of less than 689 \$/t, or a gasoline equivalent of 4.51 \$/gal. Other alternative ammonia sources were more expensive, however, they may become economical as fossil fuel costs increase and technological advances improve the alternative fuel technology.

The storage analysis of ammonia and hydrogen showed that the ammonia storage system is 93.6% efficient when the ammonia synthesis energy is included in the calculation, which was calculated by dividing the chemical energy stored by the chemical and electrical energy added to the storage vessel. In comparison, hydrogen is only 76.9% efficient. Ammonia also required nearly five times less energy for low temperature storage than hydrogen. In addition, ammonia has a storage cost advantage over hydrogen with an estimated cost for 182 days of storage to be 14.83 \$/kg-H₂ and 0.51 \$/kg-H₂, respectively.

Comparing the transportation of the two fuels showed that ammonia is more efficient and less expensive than hydrogen to transport in a pipeline. Specifically, the efficiency for transporting the fuel 1,610 km and delivering it at fueling pressure is 93.4% and 86.9% for ammonia and hydrogen, respectively. The ammonia calculation also includes the losses

involved with ammonia synthesis from a hydrogen source. Pipeline transportation costs are estimated to be 0.70-3.22 \$/kg for hydrogen, and 0.0344 \$/kg for ammonia. The ammonia delivery cost in hydrogen terms is 0.194 \$/kg-H₂, which makes hydrogen at least three times more costly to transport than ammonia.

CHAPTER 1. OVERVIEW OF AN AMMONIA ECONOMY

The current use of oil as a primary energy source for transportation creates many challenges to overcome. Specifically, the combustion of oil generates greenhouse gas emissions, which are damaging to the environment, and it leads to a dependence on a resource with a finite supply. The cost of oil and transportation fuel has been steadily increasing, which in turn has increased the cost of goods that rely on oil for production or shipment. An alternative transportation fuel that is not oil-based could help to solve these issues.

Ammonia (NH_3) and hydrogen (H_2) are the only alternative fuels that are both carbon free and can be produced from any energy resource. More than thirty years of research has been done on the production, transportation, and use of hydrogen for use in a Hydrogen Economy. However, even though initial research into ammonia as a transportation fuel is promising, there have been only limited studies of an Ammonia Economy. However, these limited studies show that an Ammonia Economy could achieve the same benefits of a Hydrogen Economy while using existing infrastructure to hasten the transitioning to an alternative fuel.

The concept of the Hydrogen Economy is to use hydrogen fuel as a means to store and carry energy in a manner similar to a battery. A hypothetical Hydrogen Economy could use many energy sources to produce hydrogen; therefore the monopoly of oil is eliminated and the lowest cost energy sources can compete to produce the fuel, which would ultimately lower the consumer price. These energy sources include alternative energy technologies, such as wind, solar, and nuclear, which do not produce greenhouse gasses and can be produced domestically. Hydrogen fuel would facilitate the fueling of vehicles quickly, similar to current gasoline and diesel transportation fuels. Conversely, the use of an electric battery will not allow for fast refueling with existing technology. Hydrogen would be utilized in internal combustion engines and fuel cells for conversion to mechanical and electrical power, respectively. In addition, the only product of hydrogen combustion is pure water; water is an environmentally benign chemical and no greenhouse gasses are emitted during combustion, in contrast to fossil-fuel based transportation fuels.

The Hydrogen Economy appears to be a solution to the energy problem based on its benefits. However, after more than thirty years of research, hydrogen is still not a commonly used transportation fuel. Furthermore, the physical characteristics of hydrogen, such as low energy density, embrittlement of metals, difficulty in storage and transportation, makes hydrogen a challenging fuel to use for transportation. A different fuel, namely ammonia, is needed that can provide the benefits of hydrogen while eliminating the physical barriers to the implementation of a Hydrogen Economy.

Ammonia is the fuel that can realize the potential benefits of the Hydrogen Economy while also having the physical characteristics that allow it to be easily transported and stored. The Ammonia Economy is nearly identical in concept to the Hydrogen Economy. Just like hydrogen, ammonia is not a primary energy source, rather it is used as a means to store and carry energy. Also, ammonia can be created from potentially any energy source, unlike oil-based transportation fuels that have only one finite source of energy. Similar to hydrogen, the ammonia is transported to consumers and is ultimately used in either an internal combustion engine or an ammonia fuel cell. The products of ammonia combustion are pure water and nitrogen, both of which are harmless to the environment.

Ammonia is a much higher density fuel than hydrogen. The physical properties of ammonia are similar to propane, in that it can be stored as a liquid at a moderate pressure of 17 bar [1]. At this pressure, ammonia has an energy density of 13.77 MJ/L whereas hydrogen would have an energy density of 0.20 MJ/L. Therefore, hydrogen is typically compressed to a much higher pressure to be stored at a higher energy density. The densest form of hydrogen is liquid hydrogen at -253°C with an energy density of 9.98 MJ/L. Therefore, liquid ammonia has an energy density 38% higher than liquefied hydrogen at conditions that are much easier to maintain. Of special importance, this higher density for ammonia allows more fuel to be stored in the limited vehicle space.

Ammonia is currently used as a fertilizer to supply nitrogen to plants. As a result, it is the second most common chemical produced in the world [1]. Further, there are over 100 years of industrial experience in the production and handling of ammonia. In addition, the well-established infrastructure for ammonia consists of worldwide distribution networks

consisting of ships, barges, rail cars, semi trailers, and pipelines that move ammonia from the producer to the end user.

Ammonia has the potential to be a widely used chemical energy carrier, which would form the basis of a future Ammonia Economy. In addition, ammonia provides all of the benefits of a hydrogen transportation fuel while also having the physical characteristics to overcome the challenges of using hydrogen, namely the low energy density, embrittlement, and difficulty in storage and transportation. The subsequent chapters describe the production of both hydrogen and ammonia along with a storage and transportation comparison for the two fuels.

CHAPTER 2. HYDROGEN PRODUCTION

Ammonia is synthesized from hydrogen and nitrogen, although the majority of the feedstock costs are associated with the production of hydrogen. Consequently, the future of the Ammonia Economy is dependent on the availability of a low cost and environmentally-friendly source of hydrogen. Presently, hydrogen production is mostly done by using fossil fuels, such as natural gas and coal. However, both of these fuels have a limited supply, and in addition, they release greenhouse gasses during the production of hydrogen. Therefore, for both environmental and economic reasons, alternative energy sources must be pursued for the purposes of producing hydrogen in an Ammonia Economy. Although the cost of hydrogen from fossil-fuel plants has historically been cheaper than alternative energy sources, the variable fuel cost of operating fossil-fueled facilities is increasing, and the cost of alternative energy technology is decreasing as economies of scale are achieved.

This chapter compares the cost of hydrogen production between conventional fossil-fuel sources (i.e. coal and natural gas) and alternative energy sources (i.e. nuclear, solar, wind, and biomass). All costs given in this chapter are reported in 2007 dollars adjusted from the original studies by using the Chemical Engineering Plant Cost Index , which includes equipment, construction, building, and engineering and supervision costs for chemical plants [2]. The original costs and year of study can also be found in this chapter.

2.1 Fossil Fuel Based Hydrogen Sources

Natural gas and coal are currently the two main feedstocks used for hydrogen production. The technology for hydrogen production from both of these feedstocks is well advanced, and significant experience exists in the operation of these types of plants. In the near term, these hydrogen producing plants will continue to be built and operated. The following describes the processes used in existing plants and the associated costs.

2.1.1 Converting Fossil Fuel to Hydrogen

The conversion of both natural gas and coal to hydrogen is a similar process in that both processes use the hydrocarbon fuel as both the hydrogen source and the energy source to drive the process. Also, in both processes the fuel is combined in an exothermic reaction

with oxygen and steam to produce synthetic gas, which mainly consists of carbon monoxide and hydrogen along with some water, carbon dioxide, and methane [1]. The synthetic gas is further processed by using reactions to shift the carbon monoxide and methane into hydrogen. The two main chemical reactions, which are the steam-methane and CO shift reactions, are shown in Equation 1 and 2.



The gas also goes through several treatments to remove carbon dioxide and trace substances in the gas stream, such as particulates, sulfur compounds, nitrogen compounds, and other contaminants [3].

2.1.2 Hydrogen from Natural Gas

Natural gas is a fuel consisting mostly of methane produced through the decay of organic materials. Further, most natural gas is obtained from wells, although it can be produced from organic waste through the use of digesters.

2.1.2.1 Natural Gas Resource

Natural gas is typically found near areas with large oil or coal reserves. The countries and areas with the largest reserves are shown in Figure 1. Russia has the largest proved reserves of 44.65 Tm³, followed by Middle East nations such as Iran and Qatar with 27.80 Tm³ and 25.60 Tm³, respectively [4]. The United States has a relatively small reserve of 5.98 Tm³, and most European countries have proved reserves far less than 1% of the world total [4]. Worldwide, there are 177.36 Tm³ of proved reserves, which is expected to last about 60 years at the current consumption rate [4].

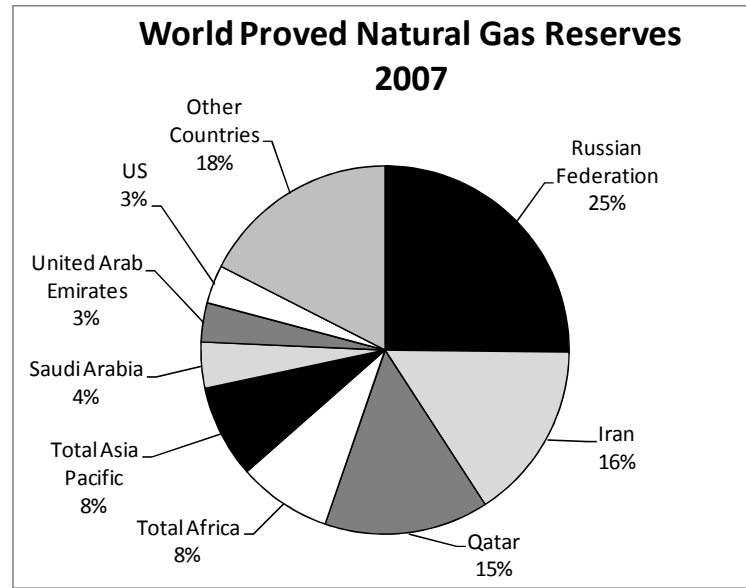

Figure 1: World natural gas reserves by country [4]

2.1.2.2 Economic Studies

The cost of producing hydrogen by using steam methane reforming is highly sensitive to the cost of natural gas, and Gray and Tomlinson have developed an equation to show this relationship, as follows [5].

$$\text{Hydrogen Cost (\$/MMBtu)} = 1.27 * \text{NG price (\$/MMBtu)} + 0.985 \quad (\text{Equation 3})$$

Equation 3 is applicable to facilities with about 100 million standard cubic feet per day (SCFD) (236,239 kg/day) of production capacity with a capital cost of 0.65-0.80 \\$/SCFD of plant capacity. The plant thermal efficiency is 70% or higher, based on the higher heating value of natural gas [5]. Natural gas cost approximately 10.00 \\$/MMBtu in April 2008 for industrial users [6], and by using the Gray and Tomlinson equation, the hydrogen cost at this price is approximately 2.48 \\$/kg when adjusted to 2007 dollars and SI units.

A similar hydrogen cost equation is given by Penner in Equation 4 as follows [7].

$$\text{Hydrogen Cost (\$/kg)} = 0.286 * \text{NG price (\$/MMBtu)} + 0.15 \quad (\text{Equation 4})$$

Using the same natural gas cost of 10.00 \\$/MMBtu, the Penner equation gives a hydrogen cost of 3.17 \\$/kg in adjusted 2007 dollars, which is higher than the cost given by the Gray

and Tomlinson value of 2.48 \$/kg. Plant size and operating assumptions were not given with Equation 4.

Two studies of hydrogen production from steam methane reforming, with and without carbon capture technology, have been completed by Rutkowski [8, 9]. Both plants have a design capacity of 379,387 kg/day and output 341,448 kg/day at 90% capacity factor. The studies used cost data from 1995 with a natural gas cost of 0.24 \$/Nm³ (6.59 \$/MMBtu). The cost of natural gas was adjusted in this paper to 0.364 \$/Nm³ (10.00 \$/MMBtu) to correspond with current natural gas prices. The hydrogen cost was also adjusted to 2007 dollars, resulting in a production cost of 2.55 \$/kg and 2.33 \$/kg for steam methane reforming, with and without carbon capture and sequestration, respectively [8, 9].

2.1.3 Hydrogen from Coal Gasification

Coal is a fossil fuel formed millions of years ago from prehistoric vegetation. This vegetation accumulated in swamps and peat bogs where it was buried due to the movement of the earth's crust and the build-up of sediment. High pressure and temperature then contributed to the breakdown of the vegetation, eventually turning it into coal [10].

2.1.3.1 Coal Resource

At the end of 2007, the United States had the largest coal reserves in the world with 243 Gt, followed by Russia and China with 157 Gt and 115 Gt, respectively [4]. The United States has 234 years of coal reserves provided all proved reserves can be mined and consumption in the United States remains constant. Following the same assumptions and considering the coal resource and consumption of each country, Russia has 500 years, China has 45 years, and the world has 133 years of remaining coal supply [4].

Using coal as a source of fossil fuel is not without problems in that it releases carbon dioxide and other pollutants when combusted. Mining of coal causes topographical and ecological changes, especially with the mountaintop removal method used in the Appalachian Mountains. Coal gasification and carbon sequestration may be able to minimize pollutants and greenhouse gasses while changes in mining practices can reduce the environmental concerns.

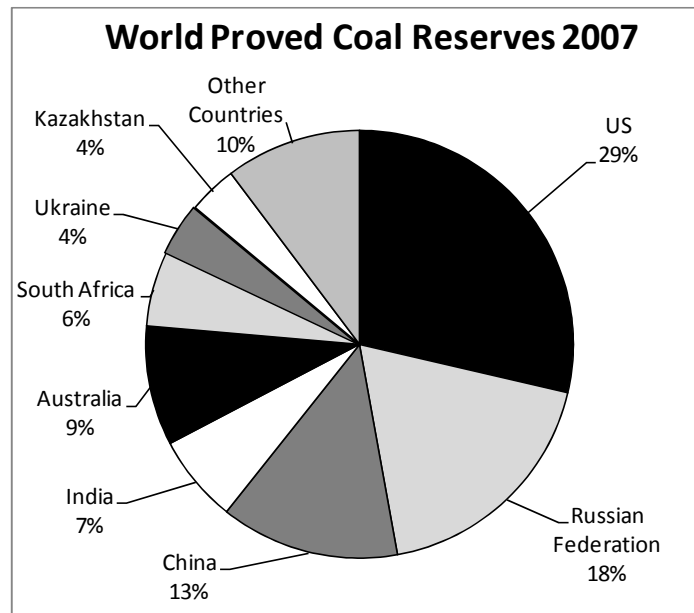

Figure 2: World coal reserves by country [4]

2.1.3.2 Economic Studies

A study by Mitretek Systems in 2002 for the U.S. DOE National Energy Technology Laboratory analyzed hydrogen production from coal and provided projected hydrogen costs [5]. The Mitretek study, authored by Gray and Tomlinson, analyzed ten different designs with different technologies and production facility sizes, thus resulting in different costs. The systems included designs with and without carbon sequestration and with varying amounts of coproduction of electrical power. Three of the designs are not included herein since they focus on electric power production and not on the production of hydrogen. Projected costs in the study have been adjusted to 2007 dollars, and estimates are based on economic assumptions given in Table 1.

Table 1: Financial assumptions for Gray and Tomlinson study [3, 5]

Debt/Equity	67/33%
Return on equity	15%
Interest on debt	8%
General inflation	3%
Coal de-escalation below general inflation	1.50%
Plant life	25 years
Depreciation DDB	15 years
Federal tax rate	34%
State tax rate	6%
Cost of carbon sequestration	\$10/ton Carbon
Cost of coal	\$29/ton AR
Construction period	3 years
Output startup year	50%

Both Texaco quench gasifiers and Conoco Phillips advanced E-gas gasifiers are compared in the study. The carbon sequestration, if so equipped, uses either conventional pressure swing adsorption (PSA) or an advanced membrane technology to remove the carbon from the gas. Plants that are primarily producing hydrogen use a heat recovery steam generator (HRSG) to generate steam and power the facility. The designs shown in Table 2 that co-produce electricity use a combined cycle (CC) plant while the more advanced plants also use a solid oxide fuel cell (SOFC) as a topping cycle in the plant design.

Table 2: Summary of Gray and Tomlinson study results for several coal gasification technologies [5]

	Design 1	Design 2	Design 3	Design 4	Design 5	Design 6	Design 7
Gasifier	Texaco	Texaco	E-gas	E-gas	E-gas	E-gas	E-gas
Carbon Sequestration	NA	PSA	Membrane	NA	PSA	PSA	Membrane
Electricity Production	HRSG	HRSG	HRSG	CC	CC	SOFC & CC	SOFC & CC
Sequestration Percentage	0%	87%	100%	0%	95%	90%	95%
H ₂ Production, kg/day	309500	281100	373300	352000	361400	352000	354400
Coal Consumption, tons/day	3000	3000	3000	6000	6000	6000	6000
HHV Efficiency %	63.7	59	75.5	62.4	56.5	64.5	65.2
Net Electrical Power, MW	20.4	26.9	25	475	358	509	519
Capital Cost, millions	495	562	573	1228	1281	1399	1375
RSP of H ₂ \$/GJ LHV	8.78	10.51	7.57	6.97	7.25	3.59	3.08
RSP of H ₂ \$/kg	1.05	1.25	0.90	0.83	0.86	0.43	0.37

The cost of the different technologies shown in Table 2 varies widely. For example, it can be seen that the solid oxide fuel cell approaches, Designs 6 and 7, provide the lowest cost for hydrogen production, but the capital cost of the plant is high. The low hydrogen cost plants also co-produce a lot of electricity, which is sold and improves the overall economics of the

plant. A plant that uses conventional technology with carbon capture, such as Design 2, has the highest cost of hydrogen.

A similar study by Kreutz et al. was completed in 2005 and compares several different methods for coal gasification and production of hydrogen and electricity [11]. All of the plants in the study use a Texaco gasifier and a Siemens V64.3a gas turbine for electricity coproduction. Sulfur removal is done with the Selexol process. All hydrogen generating plants use two water-gas shift reactors and a Selexol system for CO₂ removal. Pressure swing adsorption is used for hydrogen separation with 85% efficiency [11].

Even though the Kreutz et al. study used many different plant variations, only the plant variations that primarily produce pure hydrogen at 99.999% purity have been included in this paper. The other designs that primarily produce electricity or fuel-grade hydrogen are not included since pure hydrogen is needed for the Hydrogen Economy. Other factors that contribute to variations between the designs are gasification pressure, CO₂ venting, and syngas cooling methods. The economic assumptions for the analysis are given in Table 3.

Table 3: Financial assumptions for Kreutz et al. study [11]

Coal price (2001 avg cost to electric generators)	\$1.26/GJ LHV
Capacity factor	80%
Return on equity	15%
Interest during construction	12.3% of overnight capital
Debt/Equity	55/45%
Real discount rate	7.80%
O&M costs	4% overnight capital
Cost of CO ₂ transport and storage	\$5/tonne CO ₂
Co-product electricity price	6.23 ¢/kWh
Depreciation	MACRS
Federal and state income tax	38.2% combined
Plant life	25 years
Construction period	4 years
Levelized capital charge rate period	30 years

The results of the Kreutz et al. study are shown in Table 4 adjusted to 2007 dollars. The results show a hydrogen production cost of 1.15-1.56 \$/kg with the lowest cost being for a conventional HVQ design with a Texaco quench gasifier and no carbon capture. If carbon capture is required, the lowest cost system is the HPQ₁₂₀, which uses the same technology as the HVQ; however, the gasification process is operated at a higher pressure and PSA is used to remove the carbon.

The Kreutz et al. study shows the cost for technology available today, such as commercial gas turbines, Texaco gasifiers, and pressure-swing adsorption. Designs 1 and 2 of the Gray and Tomlinson study are comparable to the HVQ and HPQ Kreutz et al. configurations respectively, and both show a similar cost for hydrogen produced. For example, plants without sequestration have a hydrogen cost of 1.05-1.15 \$/kg, and if sequestration is included, then the cost increases to 1.25-1.36 \$/kg. In both cases, the Kreutz et al. study had a higher hydrogen cost compared to a similar design in the Gray and Tomlinson study.

Table 4: Summary of Kreutz et al. study results for several coal gasification technologies [11]

	HVQ	HPQ	HVS	HPS	HPS _y	HPS _L	HPQ ₁₂₀	HPS ₁₂₀
Gasification pressure (bar)	70	70	70	70	70	70	120	120
Carbon Sequestration	0%	91%	0%	90%	91%	74%	91%	90.12
Syngas cooling	Q	Q	R + C	R + C	R + C	R + C	Q	R + C
Coal Consumption, tonnes/day	6483	6483	6249	6249	3721	3383	4887	4638
H ₂ Production, kg/day	0	0	0	0	0	0	0	0
LHV Efficiency %	57.46	57.46	57.45	57.45	50.10	50.10	57.28	57.21
Net Electrical Power, MW	78.40	38.90	111.00	73.82	89.49	100.30	51.42	66.03
Capital Cost, millions	1138	1200	1391	1452	893	845	1164	1450
RSP of H ₂ \$/GJ LHV	9.60	11.40	11.12	12.70	13.00	12.39	11.01	13.09
RSP of H ₂ \$/kg	1.15	1.36	1.33	1.52	1.55	1.48	1.31	1.56

Q refers to quench syngas cooling, R + C refers to radiative and convective heat exchangers.

Two studies by Rutkowski completed in 2005 were performed as part of the Department of Energy Hydrogen Program Production Case Studies. The two studies use the same economic parameters, but one includes carbon capture and sequestration. The plant without sequestration produces 255,400 kg/day of hydrogen at a cost of 1.50 \$/kg [12]. If sequestration is included, the plant has a hydrogen output of 276,900 kg/day at a cost of 1.83 \$/kg [13]. The costs reported for both designs have been adjusted to 2007 dollars.

2.2 Alternative Energy Based Hydrogen Sources

As the supply of fossil fuel decreases, alternatives must be developed and used to produce hydrogen, for both environmental and economic reasons. The cost of fossil fuels is rapidly increasing while many alternative sources of energy are decreasing in cost as technologies improve and economies of scale are achieved.

2.2.1 Converting Alternative Energy Sources to Hydrogen

Alternative energy sources of hydrogen generally obtain the hydrogen molecule from water. The energy source is used to drive the hydrogen production process by using either electricity

with electrolysis or heat with a thermochemical process, which breaks water down into its hydrogen and oxygen components. Later, the hydrogen forms water when it is combusted, which in turn can be used again to create more hydrogen to provide a sustainable fuel cycle.

If the alternative energy source emits no carbon compounds during energy production, then no carbon is emitted during the production and end use of the hydrogen fuel. This is not true with fossil fuel hydrogen sources, such as natural gas and coal; fossil fuel sources use the hydrocarbon as the source for both hydrogen and process energy while emitting large amounts of carbon.

2.2.2 Hydrogen from Nuclear Energy

Nuclear energy uses controlled nuclear reactions to obtain energy from atoms. The nuclear fuel is similar to fossil fuel in that it is limited in quantity, although the quantities available are much larger and longer-lasting than fossil resources, especially if breeder reactor technologies find widespread usage. Even though nuclear generation does create waste that must be disposed of, no greenhouse gas emissions are created directly during the generation of nuclear power.

2.2.2.1 Nuclear Resource

The world proved reserves of uranium are approximately 3,622,000 tonnes, and current annual usage is 65,000 tonnes [14]. Therefore, the world has approximately 56 years of uranium supply, assuming no new sources are found and demand remains the same.

However, as uranium prices increase, more reserves are expected to be found that can be mined economically. In addition, new reactor technologies can improve the utilization of the fuel. For example, reprocessing spent fuel from conventional light water reactors and implementing breeder reactor technology could increase utilization of the fuel by a factor of 1.3 and 50, respectively [14].

2.2.2.2 Economic Studies

Significant research is being done on the generation of hydrogen from nuclear power through the Department of Energy (DOE) Nuclear Hydrogen Initiative program. The goal of the program is to build a commercial-scale hydrogen production system and have it operational by 2019.

There are three methods actively being researched to produce hydrogen from nuclear power. One method is conventional electrolysis of water by using electricity generated from nuclear power plants. The inefficiencies of several energy conversions from nuclear heat to the end product of hydrogen limits the viability of electrolysis for large scale use and has prompted research into ways to use nuclear heat directly, including thermochemical water splitting. Sulphur-iodine, hybrid sulphur, and calcium-bromine cycles are being researched since the efficiency of thermochemical water splitting processes is much higher than for electrolysis. The third method being researched is high temperature electrolysis of steam, which has a potential efficiency higher than conventional electrolysis [15].

2.2.2.3.1 Conventional Electrolysis

Ryazantsev et al. proposes the use of off-peak electrical power from nuclear reactors and conventional electrolysis for hydrogen production [16]. During dips in the electricity demand, the excess capacity of the nuclear powerplant would be used to generate hydrogen. In the Ryazantsev et al. study, a small hydrogen production facility with an electrical capacity of 30 MW and hydrogen production capacity of 14,500 kg/day would be located next to an existing nuclear powerplant [16]. This hydrogen production facility could later be expanded to 300 MW of capacity, and for one such example plant, the hydrogen production capacity is about 8,000 t/year by using off-peak electrical power [16]. The results of this analysis showed that existing nuclear powerplants can be utilized for hydrogen production without building new nuclear hydrogen production facilities

The economics of using off-peak generation for conventional hydrogen electrolysis with light water reactors was also examined by Petri et al, which resulted in a higher actual cost compared to a base-loaded hydrogen generator producing 1,000 kg/day. Using an electricity cost of 4.83 ¢/kWh, which is assumed equivalent to an industrial user rate, the cost of generated hydrogen is 4.36 \$/kg [17]. For off-peak operation, a capacity factor of only 40% was used for the hydrogen facility, compared to the 97% for the base-load plant. As a result, the cost of produced hydrogen increases to 7.36 \$/kg due to the larger plant size needed to produce the same quantity of hydrogen and the higher capital cost. In addition, this study assumed that the off-peak electricity will remain at a low cost. If a demand is created for off-

peak power by using this approach, then the daily peaks in electricity use will be minimized and off-peak electricity rates may not be available.

2.2.2.3.2 Thermochemical Processes

The thermochemical cracking process is a complex process that uses heat to break apart water into hydrogen and oxygen. Research by Schultz identified 115 different thermochemical cycles. The sulphur-iodine (SI) process proved to have the highest efficiency, and it can be used with nuclear heat [18]. The process, which is shown in Figure 3, starts by decomposing sulphuric acid at high temperatures followed by a water shift to hydrate the acids. The Bunsen reaction produces sulphuric acid and hydrogen iodide, giving off heat at temperatures below 120°C. The sulphuric acid is recycled so that it can be used in the reaction again. Hydrogen is produced by decomposing hydrogen iodide into hydrogen and iodine at 300°C while the iodine is then recycled back into the process. The hydrogen is produced with an overall efficiency of 45% based on the higher heating value of hydrogen [19].

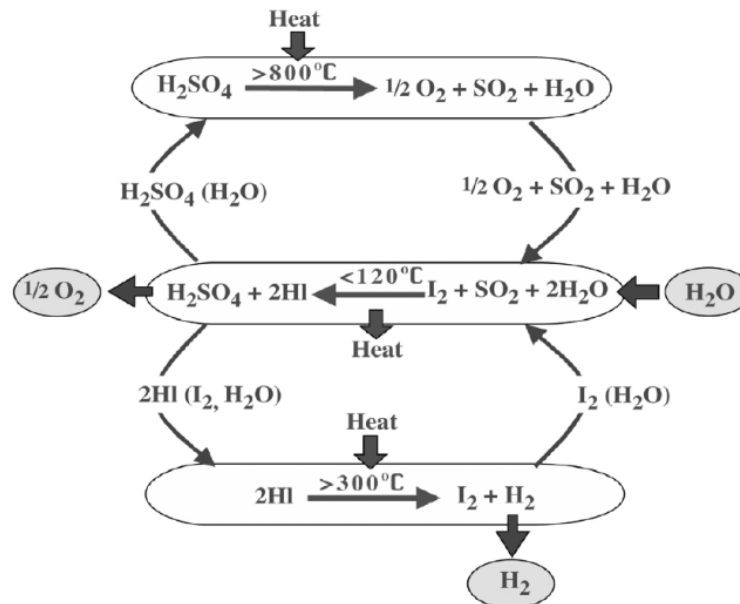

Figure 3: Sulphur-iodine thermochemical process shown by Richards et al. [19]

Thermochemical water splitting offers the advantage of a higher efficiency compared to conventional electrolysis. A study by Schultz found the General Atomics Modular Helium Reactor (MHR) combined with the sulphur-iodine (SI) process provided the best combined

system [18]. The MHR was selected based on safety, economics, high temperature operation, and the small amount of development needed for commercial operation. The conceptual design uses four Modular Helium Reactors for a total of 2,400 MW of thermal energy, which will produce hydrogen at a rate of 800,000 kg/day by using the SI process. The cost of hydrogen from such a facility is expected to be between 2.45 \$/kg and 2.63 \$/kg in 2007 dollars depending on the process temperature and the capital recovery factor [18].

Another study of MHR hydrogen production by Richards et al. showed a similar production cost as the Schultz study. According to Richards et al, hydrogen can be produced by using the SI process for 1.84 \$/kg adjusted to 2007 dollars [19].

2.2.2.3.3 High Temperature Electrolysis

A conceptual design for a high temperature electrolysis (HTE) cycle was presented by Richards et al, which recommended the MHR as the heat and power source. This reactor operates at temperatures of up to 850°C, which is much higher than the current light water reactor temperature of approximately 350°C. The higher temperature allows higher thermal efficiency for conventional electricity production, and it can supply the temperature needed for high temperature electrolysis [19].

The HTE design generates 600 MW of thermal energy and uses helium as a coolant, which drives a gas turbine to produce electricity at an efficiency of 48-52% [19]. For the high temperature electrolysis, 68 MW of heat is transferred through an intermediate heat exchanger to produce superheated steam. The rest of the thermal energy is used to produce electricity for the electrolysis of the steam in solid-oxide electrolyzer modules. Overall efficiency of the design is expected to be 55.5% based on the HHV of hydrogen [19].

2.2.3 Hydrogen from Solar Energy

Solar energy from the sun's radiation incident on the earth can be used to produce electricity directly by using photovoltaic cells or indirectly by using solar heat in a thermal heat cycle. The use of heat is typically at high temperatures, which are achieved by using solar furnaces or other concentrating devices.

2.2.3.1 Solar Resource

The energy available from solar radiation is immense in that a total of 5.457×10^{18} MJ reaches the Earth's surface annually [20]. In 2005, the total energy consumption of the entire earth from all sources of energy was 4.883×10^{14} MJ, which is several orders of magnitude less than the solar energy striking earth [21]. Only a small amount of land is needed to meet the Earth's energy needs with solar technology. For example, if a solar collector system operated at 10% conversion efficiency to electricity, then less than one percent of the world land area would be covered in solar collectors while still meeting the energy needs for all human activities.

2.2.3.2 Economic Studies

Several different technologies can be used for the solar energy to hydrogen conversion with one approach being electrolysis of water by using photovoltaics or concentrating solar and a thermal power cycle. The other approach being thermochemical processes by using high-temperature heat from concentrating solar to break water into hydrogen and oxygen. Since there are cost differences associated with each technology, a wide range of selling prices for hydrogen result.

2.2.3.2.1 Photovoltaic Electrolysis

Photovoltaic technology converts solar radiation directly into electricity with no moving parts in the energy conversion system. There are many types of solar cells produced, with the most common at this time being silicon based. Thin film panels, which either do not require silicon or use much smaller amounts, are starting to be mass produced and commercially available. However, they typically have lower efficiencies compared to silicon-based photovoltaic panels.

Gray and Tomlinson estimate the cost of hydrogen from photovoltaic electrolysis to vary from 0.98 \$/kg to 6.02 \$/kg in 2007 dollars depending on system cost [5]. The study assumes 18% photovoltaic efficiency and 85% electrolysis efficiency with a 231 \$/kW electrolyzer [5]. The low hydrogen cost of 0.98 \$/kg assumes a future low cost of 0.30 \$/W_{Peak} for the photovoltaic system, although the study specifically states current prices are

much higher. The estimate of 6.05 \$/kg is much closer to the capital cost of a current system at 2.40 $\$/W_{\text{Peak}}$.

A study by Glatzmaier et al. estimated a cost of hydrogen between 5.78 \$/kg and 23.27 \$/kg depending on the cost of the photovoltaic system [22]. The low estimate is for an installed photovoltaic cost of 0.75 $\$/W_{\text{Peak}}$, which could be considered a future system cost with improved technology. A more realistic cost of an installed photovoltaic system with current technology is 5.00 $\$/W_{\text{Peak}}$, which corresponds with the 23.27 \$/kg cost of hydrogen. The study used an electrolyzer capital cost of 450 \$/kW with an efficiency of 82% and a capacity factor of the plant estimated at 0.28. Both costs estimates are for a plant sized to 10 MW of electric power, which produces hydrogen at a rate of approximately 1,400 kg/day.

The high cost of a hydrogen-producing photovoltaic plant, along with the low capacity factor due to daily cyclical cycles in hydrogen production, greatly affects the economics of the plant. Currently, the cost of electricity from photovoltaic systems is 0.2134 \$/kWh [23]. Electricity from wind and other commercial energy sources costs about one-fourth as much as solar, and therefore improvements will have to be made in cost effectiveness of solar photovoltaic technology for it to be feasible in the future [24].

One of the improvements that may make solar photovoltaic hydrogen possible is lower cost solar panels. The current cost of a silicon photovoltaic panel is about 4.83 $\$/W_{\text{Peak}}$ [23]. With the cost of the other required components and installation, the cost of a 50 kW and 500 kW system are 6.84 $\$/W_{\text{Peak}}$ and 4.95 $\$/W_{\text{Peak}}$, respectively [23]. Companies have recently started marketing thin film solar panels and selling them at a cost as low as 0.99 $\$/W_{\text{Peak}}$ by printing solar cells on an aluminum backing without the use of silicon [25]. Such developments currently being researched and commercialized could bring commercial systems to a price competitive with competing sources of energy.

2.2.3.2.2 Concentrated Solar

Concentrating solar technology typically uses mirrors to concentrate sunlight on a receiver, thus heating the receiver to a high temperature. A thermodynamic power cycle can operate between the high temperature of the receiver and the ambient temperature. Both central

collectors and distributed collectors can be used for power generation and hydrogen production.

A central receiver system consists of a tower with a receiver on top, hundreds or thousands of heliostats to reflect the sunlight to the receiver, and a thermodynamic cycle to convert the solar heat into mechanical or electrical power. Each heliostat, which is a reflecting mirror, has an individual controller to change the angle of the surface to reflect sunlight to the receiver at all hours of the day. The receiver is cooled by a fluid that can be stored and then used to heat a secondary fluid for use in a power cycle.

A distributed system uses many concentrators to focus solar radiation by using either a line or point focus system. A line focus system uses parabolic troughs to focus sunlight on a pipe containing a heat-transferring fluid. The fluid is pumped through the pipes and then the system is operated in the same manner as a central receiver system. Point focus systems use a parabolic dish collector to focus light at a receiver located at the focal point of the dish. The heat is used to heat a fluid, or to power a Stirling engine. Both distributed systems use a controller to track the sun and focus the sunlight on the receiver.

A study by Glatzmaier et al. [22] investigated the available technology and the cost of concentrated solar for both central and distributed receiver systems. The plant would use electrolyzers at 79.5% efficiency and a cost of 500 \$/kW to convert the electrical energy into hydrogen. Estimates were provided for expected costs in 2010 and 2020, with costs decreasing in the future. However, only the 2010 costs are reported herein since they come closer to reflecting current prices.

The first design considered was for a solar Stirling-dish engine design with a parabolic dish mirror. The total plant size was 10 MW of electrical output and the plant capacity factor was 0.28, which is equivalent to a hydrogen output of 1,356 kg/day. The cost of hydrogen from the facility is expected to be 10.49 \$/kg [22].

The second design was for a solar power tower with 200 MW of electrical output. The plant uses thermal storage to give the plant a capacity factor of 0.65, which is more than double the

Stirling-dish engine capacity factor without thermal storage. Hydrogen in this system is produced at a rate of 62,950 kg/day at a cost of 6.46 \$/kg [22].

Kolb et al. also provided an estimate of hydrogen cost for a central receiver system with electrolyzers. The electrolyzers would operate at 80% efficiency with a capacity factor of 76% based on using thirteen hours of molten-salt thermal storage. The solar-to-hydrogen efficiency would be 15%, and the system would output hydrogen at a rate of 38,356 kg/day for a cost of 5.10 \$/kg [26].

2.2.3.2.3 Thermochemical

Concentrated solar radiation can produce high temperatures for use in thermochemical cycles. Specifically, by using a solar power-tower type design, temperatures of 1,000°C can be reached. Kolb et al. suggested the use of a sulfuric acid/hybrid thermochemical cycle with a power tower. Such a system could have a solar-to-hydrogen efficiency of about 21% with a hydrogen cost of 2.80 \$/kg [26]. Compared to a similar solar plant analysis by Kolb et al. for a system that uses electrolysis, the thermochemical system provides a lower cost of hydrogen at a higher overall efficiency.

Giaconia et al. suggests the use of a combined solar and natural gas system to produce hydrogen [27]. The system uses the sulphur-iodine reaction, which is the same reaction used for nuclear thermochemical cycles shown in Figure 3. The proposed system would use methane for the high temperature sulfuric process and then concentrating solar would be used as the heat source for the lower-temperature hydrogen-iodide section of the reaction. The solar energy could also be stored as a molten salt for use as needed.

The system was designed in this way in order to maintain a constant hydrogen output by eliminating the problems caused by the intermittent solar energy heat source. Specifically, thermal storage provides a much more constant supply of solar energy and then natural gas can be used when not enough solar energy is available. Hydrogen output remains constant and 70% of the thermal energy needed for hydrogen production comes from solar. The capital cost of the plant is high, and as a result the cost of hydrogen produced is also relatively high at 7.53 \$/kg [27].

2.2.4 Hydrogen from Wind Energy

Wind energy uses the power available in wind to rotate a turbine and produce electricity. Most modern turbines use a horizontal-axis turbine design, although vertical-axis wind turbines are also manufactured. Wind turbines are typically constructed in large groups of individual wind turbines in order to form a large wind farm.

2.2.4.1 Wind Resource

Wind is an indirect form of solar energy in that approximately 2% of all solar radiation on the earth surface is converted to kinetic energy of moving air with about 30% of this energy being within 1,000 m of the earth surface [20]. The United States wind potential is estimated to be 10,777 TWh/year, which is two and a half times more energy than the 4,368 TWh of electrical energy production in 2007 [4, 28].

2.2.4.2 Economic Studies

There are several variations of hydrogen production from wind power design. One system would be completely grid independent so that all of the energy from the wind turbines would be used to electrolyze water to produce hydrogen. Due to the variable output of wind turbines and their relatively low capacity factor, the production of hydrogen would continually fluctuate and the capacity factor of the electrolyzer would also be low. Sizing the electrolyzer for a lower wind-plant capacity factor would help decrease the capital cost of the electrolyzer, but as a result excess wind power would not be utilized during high wind periods. However, connecting the system to the grid would provide the advantage of a constant supply of electricity. The electrolyzers could operate at a high capacity factor by using both energy from the wind and the grid, but the hydrogen produced would not be completely renewable unless the grid energy was also produced from a completely renewable source.

According to Sherif et al, intermittent electrolyzer operation is not desirable in terms of electrolyzer efficiency, safety, and heat management [29]. Specifically, electrolyzers operate at a cell voltage of around two volts, and power conditioning equipment would be required to convert the variable power from the wind turbines into electrical energy at the proper voltage. In addition, losses in this equipment would consume some of the energy, thus

reducing efficiency. Electrolyzers operating at low capacity could produce hydrogen and oxygen at such a low rate that the gasses could permeate through the electrolyte and come into contact, possibly causing a hazardous flammability condition within the electrolyzer [29]. Alkaline electrolyzers are especially sensitive to this problem, but PEM electrolyzers also have the same problem to a lesser extent. Electrolyzer operating temperature is also important, and operating at below normal temperatures decreases efficiency. The variable power from the wind might not allow the electrolyzer to reach operating temperatures fast enough so that the electrolyzers would stay below the range of efficient power production during a significant portion of operating time [29].

A study by Bockris and Veziroglu estimated the cost of using wind for hydrogen production with a wind farm, based on assuming an average wind speed of 6.71 m/s, to be 3.50 \$/kg adjusted to 2007 dollars [24]. It should be noted that the reported cost is based on commercially available low temperature electrolyzers. In addition, high temperature electrolysis and higher wind speeds are both expected to decrease the cost of hydrogen according to the study [24].

A study by Levene et al. compares the cost of hydrogen produced with wind by using two main system designs. The first case involved producing hydrogen at a wind farm by electrolysis. Wind data from the University of Minnesota West Central Research and Outreach Center (WCROC) in Morris Minnesota and the Gobbler's Knob site near Lamar Colorado was used in the analysis with average wind speeds of 7.41 m/s and 8.50 m/s, respectively. A Vestas V82 turbine was used for the analysis at both locations since it is the turbine currently installed at the WCROC site. Electricity for the electrolyzers is assumed to cost 0.038 \$/kWh, and electricity is sold to the grid for 0.066 \$/kWh between four and seven pm during times of peak electrical demand. The electrolyzer hydrogen load of 1,000 kg/day results in a hydrogen cost of 2.27-5.55 \$/kg, depending on the wind site and the timeframe [30].

The second case is based on a hydrogen filling station with a hydrogen demand of 1,500 kg/day. Hydrogen is produced at the point of use with three existing wind farms located in Colorado (Lamar, Peetz Table, and Ponnequin) providing the energy. A signal would be sent

from the wind power sites to the electrolyzer and then hydrogen would be produced when wind power is available [30]. The cost of hydrogen from such a system costs 2.33-4.03 \$/kg depending on the timeframe [30]. It should also be noted that the cost of transporting the hydrogen to the filling station is eliminated in the second case, although electrical transmission from the wind farm to the electrolyzer would still be required. This design also benefits from a potentially higher capacity factor since three wind sites over a large geographic area are being used instead of just one wind site.

The differences in cost depending on timeframe are due to a few assumptions such as electrolyzer costs decreasing in the future, with costs of 740 \$/kW, 400 \$/kW, and 300 \$/kW assumed in the near, mid, and long term, respectively. In addition, the hydrogen is assumed to be compressed to 448 bar after production with the compressor cost decreasing in the future to \$600,000, \$300,000, and \$100,000 for a 1,500 kg/day compressor in near, mid, and long term, respectively [30].

The results shown in Table 5 show a decrease in cost when producing hydrogen at the point of use and at sites with higher wind speeds. Levene et al. also noted that a more integrated approach to generating hydrogen from wind power could decrease costs [30]. For example, wind turbines generate AC power at variable frequency, which is converted to DC power and converted back to AC power at grid frequency. Currently, most electrolyzers use alternating current from the grid for a power source, which is converted to low voltage DC for electrolysis of water. These multiple, and possibly unnecessary, conversions add to the cost of a system so that design efforts to optimize the components and provide an integrated design could further reduce hydrogen-production costs [30].

Table 5: Summary of hydrogen production cost from wind energy by Levene et al. [30]

	Wind Speed (m/s)	Location	Near Term	Mid Term	Long Term
Case 1	7.41	WCROC	\$ 5.55	\$ 3.40	\$ 2.70
Case 1	8.50	Gobbler's Knob	\$ 4.89	\$ 2.90	\$ 2.27
Case 2	-	Point of Use	\$ 4.03	\$ 2.80	\$ 2.33

Near Term = 2006-2010. Mid Term = 2010-2020. Long Term = 2020-2030.

Costs are per kg of hydrogen generated.

Levene performed two additional wind-to-hydrogen studies in 2005 as part of the US DOE Hydrogen Program Production Case Studies. Both studies use the same assumptions and

financial parameters for hydrogen production. However, the difference is that one of the studies co-produces electricity along with hydrogen, and the other study only produces hydrogen. The hydrogen generation unit for both studies has an efficiency of 64% with an electrolyzer efficiency of 71%. The wind farm was rated at 278 MW with a capacity factor of 41% and the total hydrogen plant output is expected to be about 50,000 kg/day. The results showed hydrogen could be produced at a selling price of 6.61 \$/kg with coproduction of electricity, and 6.77 \$/kg without the coproduction of electricity, with prices adjusted to 2007 dollars [31, 32].

2.2.5 Hydrogen from Biomass

Biomass consists of biological material that can be used for industrial purposes, such as plants, wood, or waste. Biomass has historically been used as a fuel for heating by using combustion furnaces. Research is currently being done on the use of biomass to produce hydrogen from more advanced thermochemical and biological approaches.

2.2.5.1 Biomass Resource

There are four main categories of biomass resources that have the potential to be used as a feedstock. The first is energy crops, which as the name implies are specifically grown for energy content. Examples are corn, soybeans, poplar trees, and algae. Agricultural waste is the second category, which includes crop and animal waste. The third is forestry waste from harvesting trees and clearing land, while the fourth category is industrial and municipal waste [33].

The waste-to-energy application has received much attention due to its potential to become a major hydrogen source. It is estimated that 1.08×10^8 GJ of waste vegetable bio-matter is generated annually [33]. This resource is currently a waste stream and use of this energy does not require additional farmland for production.

2.2.5.2 Environmental Effects

Biomass is considered to be carbon-neutral source of energy in that the carbon dioxide released during combustion is then absorbed by the plants to produce biofuels during photosynthesis. The net effect on the concentration of carbon dioxide in the atmosphere is assumed to be zero [34].

Some recent studies have suggested that using biofuels from energy crops may actually increase greenhouse gas emissions compared to using fossil fuels. This claim is based on land-use changes caused by the increased use of biofuels and the resulting increase in agricultural land required to meet both food and fuel requirements. Searchinger et al. reports that corn and switchgrass based ethanol increase greenhouse gas emissions by 93% and 50%, respectively, compared to gasoline when the land use change is included [35]. A similar study by Fargione et al. estimates it takes 48 to 93 years for the carbon released in the conversion of unused farmland for corn production to be recovered through the use of corn based ethanol [36].

2.2.5.3 Economic Studies

Utilizing biomass resources to produce hydrogen is still a developing industry, and there are several different pathways to producing hydrogen from a feedstock. For example, thermochemical processes uses heat to break down the biomass, and biological methods produce hydrogen directly by using organisms, such as algae.

2.2.5.3.1 Thermochemical Processes

Pyrolysis and gasification of biomass are the two main processes available for thermochemical conversion of biomass into hydrogen. They differ in that pyrolysis is done in an inert environment while gasification is done in a reactive environment, typically consisting of air with or without steam [37].

2.2.5.3.2 Pyrolysis

Pyrolysis is the conversion of biomass into liquid oils, solid charcoal, and gaseous products in a nonreactive environment. The temperatures involved are typically in the 650-800 K range at a pressure of 1-5 bar.

The speed of the reaction and the temperature determines the type of pyrolysis. Slow pyrolysis involves low heating rates and lower temperatures, and charcoal is the main product from the reaction [37]. Fast pyrolysis involves fast heat rates and higher temperature, which maximizes the production of gasses [37]. Since gaseous hydrogen is the desired product from pyrolysis for use in a Hydrogen Economy, fast pyrolysis is the method considered herein.

The gaseous products from fast pyrolysis are hydrogen, methane, carbon monoxide, carbon dioxide, and other gasses. In a method similar to the steam reforming of methane, the carbon monoxide and methane are converted into hydrogen and carbon dioxide through the methane-steam reaction and the CO shift reaction, as previously shown in Equations 1 and 2 [33].

Co-production of other valuable substances from the remaining reaction products, such as adhesive resins, is important for making the technology economically feasible [38]. As a result, the cost of hydrogen from a pyrolysis facility is expected to be between 1.47 \$/kg and 2.57 \$/kg adjusted to 2007 dollars, depending on whether or not a co-product is generated and on the size of the facility [39].

2.2.5.3.3 Gasification

Biomass gasification is done at temperatures higher than pyrolysis, typically greater than 1,000 K, and the biomass is partially oxidized in a reactive environment containing oxygen [33]. The process is optimized to produce gaseous products from the biomass, although some charcoal is also formed in the process.

The type of gasification can be classified as either direct or indirect gasification. Direct gasification uses heat from the combustion of a small amount of the biomass in the reactor gasification vessel. Indirect gasification processes use heat from a nonreactive medium, such as sand, to heat the biomass in the reactor vessel. This sand is heated in a combustor that uses the charcoal from gasification to provide heat [39].

The gaseous products have a content similar to that of the gasses from pyrolysis, which was described previously. The gas is reformed by using the methane-steam reaction and CO shift reaction in order to maximize the production of hydrogen. The charcoal is broken down into hydrogen, carbon monoxide, carbon dioxide, and methane, and further refined to produce hydrogen [33].

The cost of hydrogen produced by biomass gasification is expected to be between 1.44 \$/kg and 2.83 \$/kg when adjusted to 2007 dollars [39]. Many factors, such as the size of the facility and cost of feedstock, affect the economics. Further, facilities that use direct

gasification are expected to produce hydrogen at a cost about 5% more than the indirect method [39].

A study by Mann determined hydrogen costs based on biomass gasification for a plant with an expected hydrogen output of 139,700 kg/day. The cost of biomass was assumed to be 46 \$/dry-ton, resulting in a production cost of 1.99 \$/kg when adjusted to 2007 dollars [40]. The study results are available on a spreadsheet, which allows parameters to be changed to see the effects on cost. For example, if the feedstock cost is changed to 80 \$/dry-ton for the same economic parameters and plant size, the cost of hydrogen will increase from 1.99 \$/kg to 2.30 \$/kg.

2.2.5.3.4 Biological Processes

There are five different methods of producing hydrogen by using biological processes: direct and indirect biophotolysis, biological water-gas shift reaction, photo-fermentation, and dark fermentation. The processes are based on the use of solar energy and special biological organisms adapted to produce hydrogen instead of oxygen during photosynthesis.

To date, the research on these methods has not yielded either a practical process or a conceptual process at a laboratory scale [41]. The photosynthesis process would have to operate at high conversion efficiencies in order to be practical since solar photovoltaic and electrolyzer systems operate at an overall efficiency of 13% [42]. Photosynthesis has a low efficiency, typical given as below 1% [42, 43], or even as low as 0.5% [44]. Therefore, the land area required for a similar sized hydrogen production based on biological processes could be at least 100 times larger than what would be required for photovoltaic systems, if one considers growing season and thermal cycle efficiency.

The efficiency of biologically converting sunlight into hydrogen affects the economics of such a system. In the best solar locations, the energy reaching the surface of the earth is equivalent to about 6.6 GJ/m²-year. If the hydrogen was priced at 2.12 \$/kg (15 \$/GJ), the system would be producing less than 1.00 \$/m² annually [43]. This would be equivalent to revenue of about 10,000 \$/ha, which would have to cover the capital cost of land, production

equipment, and maintenance. As one can see, the biomass technology approach will need further advancements before it will be economically feasible.

2.3 Cost of Hydrogen from Conventional and Alternative Energy Sources

In this chapter, a number of studies describing the cost of hydrogen production and the technology involved have been presented. The original data obtained from these studies is shown in Table 6, where the studies are sorted by energy source for comparison purposes.

Each hydrogen production study analyzed in this chapter was first converted to a standard set of units, namely kilograms of hydrogen. The use of energy units can cause confusion due to the difference between higher and lower heating value of a given quantity of hydrogen. Volume measurements are not used since the volume can change with temperature and pressure. A kilogram of hydrogen is the most convenient unit since the energy in one kilogram of hydrogen (119.9 MJ) is nearly equal to a gallon of gasoline (121.7 MJ) on a lower heating value basis, which makes quantities produced and costs for hydrogen easy to compare to gasoline.

To compare the results between the studies, several key variables used in the studies have been provided in Table 6. These factors include the dollar year of the study, internal rate of return (IRR), capital cost of the plant, feedstock cost, and plant size. The cost per kilogram of hydrogen produced is then given in terms of hydrogen retail selling price (RSP), which is the retail price at which the plant can sell the hydrogen at a profit while providing the specified IRR to the investors and paying for all of the capital and operational costs of the plant.

The dollar year of the study is an important parameter since costs must be compared in the same time period. Inflation causes the capital cost of a plant and the associated production cost of hydrogen to increase each year. However, the information in Table 6 is not adjusted for inflation and is reported as found in the original analysis for each hydrogen production plant.

Table 6: Hydrogen production studies summary

Study	Energy Source	Process	Study Year		Study Capital		Plant Output (kg H ₂ /day)	H ₂ RSP (\$/kg)
			Dollars	IRR (%)	Cost (M\$)	Feedstock Cost		
Gray and Tomlinson	Natural Gas	Steam Methane Reforming	1998	†	70.0	10.00 \$/MMBTU	236,239	1.84
Penner	Natural Gas	Steam Methane Reforming	2006	†	†	10.00 \$/MMBTU	†	3.01
Rutkowski	Natural Gas	Steam Methane Reforming	2005	10.0	180.7	10.00 \$/MMBTU	341,448	2.08
Rutkowski	Natural Gas	Steam Methane Reforming with Sequestration	2005	10.0	226.4	10.00 \$/MMBTU	341,448	2.27
Petri et al.	Nuclear	Electrolysis-Base Load	2006	†	†	0.0483 \$/kWh	1,000	4.15
Petri et al.	Nuclear	Electrolysis-Off Peak	2006	†	†	0.0483 \$/kWh	1,000	7.00
Richards et al.	Nuclear MHR	Sulfur-Iodine Thermochemical	2006	†	†	a	†	1.75
Schultz	Nuclear MHR	Sulfur-Iodine Thermochemical (Low Efficiency)	2003	16.5	1611.4	a	583,000	2.01
Schultz	Nuclear MHR	Sulfur-Iodine Thermochemical (High Efficiency)	2003	16.5	1894.3	a	723,000	1.87
Giaconia et al.	Solar & NG	Sulfur-Iodine Thermochemical	2007	8.0	1480.6	0.27 \$/m ³ NG	86,400	7.53
Glatzmaier et al.	Solar	Photovoltaic Electrolysis (\$5/W)	2010	15.0	54.5	b	1,399	23.27
Glatzmaier et al.	Solar	Photovoltaic Electrolysis (\$0.75/W)	2010	15.0	12.0	b	1,399	5.78
Glatzmaier et al.	Solar	Dish Stirling Electrolysis	2010	15.0	22.1	b	1,356	10.49
Glatzmaier et al.	Solar	Power Tower Electrolysis	2010	15.0	624.0	b	62,954	6.46
Gray and Tomlinson	Solar	Photovoltaic Electrolysis	1998	12.7	5563.0	b	354,359	6.05
Kolb et al.	Solar	Power Tower Electrolysis	2007	14.0	421.0	b	38,356	5.10
Kolb et al.	Solar	Sulfuric acid/hybrid Thermochemical	2007	14.0	387.0	b	93,151	2.80
Bockris & Veziroglu	Wind	Electrolysis	2006	25.0	†	0.045 \$/kWh	†	3.33
Levene et al.	Wind	Electrolysis (Near Term)	2006	10.0	3.0*	0.038 \$/kWh	1,000	5.55
Levene et al.	Wind	Electrolysis (Long Term)	2006	10.0	0.9*	0.038 \$/kWh	1,000	2.27
Levene	Wind	Electrolysis Without Electricity Coproduction	2005	10.0	499.6	b	50,000	6.03
Levene	Wind	Electrolysis With Electricity Coproduction	2005	10.0	504.8	b	50,000	5.89
Mann	Biomass	Gasification	2005	10.0	149.3	46 \$/ton	139,700	1.77
Padró and Putsche	Biomass	Pyrolysis (Low Estimate)	1995	†	53.4	46.30 \$/t	72,893	1.06
Padró and Putsche	Biomass	Pyrolysis (High Estimate)	1995	†	3.1	16.50 \$/t	2,696	1.86
Padró and Putsche	Biomass	Gasification (Low Estimate)	1992	†	175.1	46.30 \$/t	194,141	1.04
Padró and Putsche	Biomass	Gasification (High Estimate)	1995	†	6.4	16.50 \$/t	1,977	2.05
Gray and Tomlinson	Coal	Coal Gasification With Sequestration	1998	15.0	417.0	29 \$/ton	281,100	0.93
Gray and Tomlinson	Coal	Coal Gasification Without Sequestration	1998	15.0	367.0	30 \$/ton	309,500	0.78
Gray and Tomlinson	Coal	Advanced Gasification With Sequestration	1998	15.0	1019.0	31 \$/ton	354,400	0.27
Kreutz et al.	Coal	Coal Gasification With Sequestration	2002	15.0	903.2	1.26 \$/GJ	770,700	1.02
Kreutz et al.	Coal	Coal Gasification Without Sequestration	2002	15.0	857.0	1.26 \$/GJ	770,700	0.86
Rutkowski	Coal	Coal Gasification With Sequestration	2005	10.0	545.6	1.15 \$/GJ	276,900	1.63
Rutkowski	Coal	Coal Gasification Without Sequestration	2005	10.0	435.9	1.15 \$/GJ	255,400	1.34

† Study did not provide data for this value *Study assumes purchased wind energy and does not include capital cost of turbines

a Feedstock cost not given b Renewable energy with feedstock cost included in plant capital

The internal rate of return (IRR) is included when available for each study so as to allow a better comparison between the studies. Internal rate of return is an economic term that refers to the yield of the investment in the plant over the entire life of the plant. A higher rate of return results in a higher cost of hydrogen produced, but also in a more attractive investment for potential investors in the project due to a higher yield.

The capital cost and plant size are two related quantities. In general a larger plant, which uses the same technology, will cost more to build. The capital cost of the plant is a useful term since it shows the amount of money needed to be raised from investors or through loans before a plant can be constructed. The plant size shows what output capacity is possible if such a facility is producing hydrogen.

Feedstock costs affect the selling price of hydrogen and are an important factor to consider when comparing the different studies. The feedstock costs in Table 6 are given with the units provided in the original study. However, the feedstock cost has been adjusted to a cost per GJ of energy and given in Table 7.

All costs were adjusted to 2007 dollars by using the Chemical Engineering Plant Cost Index [2]. The production cost index value used for each study is included in Table 6, and all were adjusted to the 2007 index value of 525.4. The only exceptions to this are the solar and some of the wind studies, which were not adjusted since these studies were given with capital costs reflecting current costs and no adjustment is needed. It should be noted that solar technology is still developing, and the cost for such facilities is decreasing [23].

As can be seen in Table 7, hydrogen production cost is lowest with coal, biomass, and nuclear sources of energy while the highest costs are from solar and wind. However, it should be noted that both solar and wind require no fuel input, and as the cost of feedstock for the more economical alternatives increase, solar and wind may be more economic relative to other alternatives.

Table 7: Hydrogen production studies adjusted for inflation

Study	Energy Source	Process	Cost Index for Year	Study Capital Cost (2007) (M\$)	Feedstock Cost (\$/GJ)	Plant Output (kg H ₂ /day)	H ₂ RSP (\$/kg) (2007)
Gray and Tomlinson	Natural Gas	Steam Methane Reforming	389.5	94.4	10.55	236,239	2.48
Penner	Natural Gas	Steam Methane Reforming	499.6	0.0	10.55	†	3.17
Rutkowski	Natural Gas	Steam Methane Reforming	468.2	202.8	10.55	341,448	2.33
Rutkowski	Natural Gas	Steam Methane Reforming with Sequestration	468.2	254.1	10.55	341,448	2.55
Petri et al.	Nuclear	Electrolysis-Base Load	499.6	†	13.42	1,000	4.36
Petri et al.	Nuclear	Electrolysis-Off Peak	499.6	†	13.42	1,000	7.36
Richards et al.	Nuclear MHR	Sulfur-Iodine Thermochemical	499.6	†	b	†	1.84
Schultz	Nuclear MHR	Sulfur-Iodine Thermochemical (Low Efficiency)	401.7	2107.6	b	583,000	2.63
Schultz	Nuclear MHR	Sulfur-Iodine Thermochemical (High Efficiency)	401.7	2477.6	b	723,000	2.45
Giaconia et al.	Solar & NG	Sulfur-Iodine Thermochemical	a	1480.6	7.08	86,400	7.53
Glatzmaier et al.	Solar	Photovoltaic Electrolysis (\$5/W)	a	54.5	c	1,399	23.27
Glatzmaier et al.	Solar	Photovoltaic Electrolysis (\$0.75/W)	a	12.0	c	1,399	5.78
Glatzmaier et al.	Solar	Dish Stirling Electrolysis	a	22.1	c	1,356	10.49
Glatzmaier et al.	Solar	Power Tower Electrolysis	a	624.0	c	62,954	6.46
Gray and Tomlinson	Solar	Photovoltaic Electrolysis	a	5563.0	c	354,359	6.05
Kolb et al.	Solar	Power Tower Electrolysis	a	421.0	c	38,356	5.10
Kolb et al.	Solar	Sulfuric acid/hybrid Thermochemical	a	387.0	c	93,151	2.80
Bockris & Veziroglu	Wind	Electrolysis	499.6	†	12.50	†	3.50
Levene et al.	Wind	Electrolysis (Near Term)	a	3.0*	10.56	1,000	5.55
Levene et al.	Wind	Electrolysis (Long Term)	a	0.9*	10.56	1,000	2.27
Levene	Wind	Electrolysis Without Electricity Coproduction	468.2	560.6	c	50,000	6.77
Levene	Wind	Electrolysis With Electricity Coproduction	468.2	566.5	c	50,000	6.61
Mann	Biomass	Gasification	468.2	167.5	2.81	139,700	1.99
Padró and Putsche	Biomass	Pyrolysis (Low Estimate)	381.1	73.7	2.57	72,893	1.47
Padró and Putsche	Biomass	Pyrolysis (High Estimate)	381.1	4.2	0.92	2,696	2.57
Padró and Putsche	Biomass	Gasification (Low Estimate)	381.1	241.4	2.57	194,141	1.44
Padró and Putsche	Biomass	Gasification (High Estimate)	381.1	8.8	0.92	1,977	2.83
Gray and Tomlinson	Coal	Coal Gasification With Sequestration	389.5	562.5	1.24	281,100	1.25
Gray and Tomlinson	Coal	Coal Gasification Without Sequestration	389.5	495.0	1.24	309,500	1.05
Gray and Tomlinson	Coal	Advanced Gasification With Sequestration	389.5	1374.5	1.24	354,400	0.36
Kreutz et al.	Coal	Coal Gasification With Sequestration	395.6	1199.5	1.26	770,700	1.36
Kreutz et al.	Coal	Coal Gasification Without Sequestration	395.6	1138.2	1.26	770,700	1.15
Rutkowski	Coal	Coal Gasification With Sequestration	468.2	612.3	1.15	276,900	1.83
Rutkowski	Coal	Coal Gasification Without Sequestration	468.2	489.2	1.15	255,400	1.50

† Study did not provide data for this value *Study assumes purchased wind energy and does not include capital cost of turbines

a Costs reflect current prices and are not adjusted b Feedstock cost not given c Renewable energy feedstock cost included in plant capital

One kilogram of hydrogen is approximately equivalent to one gallon of gasoline based on lower heating value energy content. Any hydrogen sources that have a hydrogen cost below the current cost of gasoline have an economic advantage over gasoline. Based on recent gasoline prices in the 2.00 to 4.00 \$/gal retail price range, many of the studies surveyed in this chapter have a competitive cost. It should be noted that the hydrogen cost estimates given in this chapter are independent of oil prices, and therefore these estimates are applicable regardless of future changes in the price of gasoline.

The fossil fuel based hydrogen sources of natural gas and coal have a price range of 2.33-4.00 \$/kg and 0.36-1.83 \$/kg, respectively. Looking at the capital cost figures for the two plant designs in Table 7 shows coal plants cost significantly more than a natural gas plants. Coal-to-hydrogen facilities will cost more money than a comparably sized natural gas plant, but have the benefit of a lower cost feedstock, especially since proven coal reserves in the United States can last for hundreds of years. In contrast, a natural gas plant has a relatively low capital cost, but the feedstock cost is much higher and proven reserves are much smaller than that of coal. Natural gas plant production costs for hydrogen are highly dependent on natural gas prices while the cost of hydrogen from a coal plant depends mostly on the initial capital cost of the facility since coal as a feedstock is relatively cheap. Further, even the most expensive hydrogen from coal given in Table 7 includes carbon sequestration to minimize environmental impacts. Also, at a cost of 1.83 \$/kg, hydrogen from coal is cheaper than the lowest cost estimate of 2.33 \$/kg for hydrogen from natural gas.

Hydrogen from alternative energy costs more than fossil fuel sources based on data found in this survey. The lowest cost hydrogen from each alternative energy sources may be comparable or cheaper than for fossil fuel technology, but many of the low cost renewable technologies have never been implemented and are based on future costs.

Biomass provides a promising cost of hydrogen in the 1.44- 2.83 \$/kg range. The issue with biomass is whether there is enough land to produce the amount of fuel and food needed in the world. If a waste stream, such as municipal solid waste or other organic matter, can be used in these processes, then biomass could provide an important role as a renewable feedstock for hydrogen production.

Nuclear hydrogen sources could provide a low cost hydrogen supply by using future gas-cooled Generation IV reactors, with a low hydrogen cost of 1.84 \$/kg. However, the use of today's water-cooled Generation III reactors gives a cost of 4.36 \$/kg if the electrolyzers are base-loaded, or a cost of 7.36 \$/kg if the electrolyzers only use off-peak electricity. Although nuclear energy could provide large quantities of cost-effective and carbon-free hydrogen, it will be several years before the next generation reactors are in operation and able to provide hydrogen with favorable economics.

Solar energy resources vary widely in production cost. For electrolytic production of hydrogen with photovoltaic technology, the cost ranges from 5.78 \$/kg to 23.27 \$/kg. The low cost is based on the price of photovoltaic panels available in the future, and the high price is more indicative of current prices, which shows that photovoltaic hydrogen production is clearly not economical at this time. The use of a concentrating solar design with thermal storage improves the economics by allowing the electrolysis units to operate at a higher capacity factor. The lowest cost system uses the high temperatures available from solar energy in a thermochemical cycle to produce hydrogen at a cost of 2.80 \$/kg.

Thermochemical processes and concentrating solar achieve economies of scale at large plant sizes, unlike electrolysis units and photovoltaic panels which tend to scale linearly. For example, doubling the size of a thermochemical process by using a scaling factor of 0.65 would result in a 57% cost increase, while doubling the cost of an electrolyzer or photovoltaic system would double the cost.

Wind technology is currently high priced, but it is a renewable energy source that is being commercially developed today, and as a result, it is achieving economies of scale. The range of hydrogen production cost was found to be 2.27 \$/kg to 6.77 \$/kg. The high cost of 6.77 \$/kg is likely with a large-scale modern system, which is significantly less than the 23.27 \$/kg price of current available solar photovoltaic technology. Wind-to-hydrogen may also allow wind energy to be harnessed in areas without electrical transmission capacity, or it could provide an energy storage medium for the intermittent wind resource in order to provide a more constant renewable electricity supply.

An economic comparison based on the energy content of hydrogen and gasoline alone does not account for the efficiency gains a Hydrogen Economy has over gasoline powered vehicles. A fuel cell and electric motor may be as much as twice as efficient in converting fuel into useable mechanical energy compared to an internal combustion gasoline engine. With twice the efficiency in end use, the cost of hydrogen could be twice as high as gasoline and still be competitive. This would make nearly all production technologies found in this analysis economical at recent gasoline prices in the 2.00 to 4.00 \$/gal range.

2.4 Summary

Hydrogen is one of the primary feedstocks for ammonia production. Therefore, an economical source of hydrogen is needed for low-cost production of transportation fuel in the Ammonia Economy. In this chapter, costs for hydrogen were found from energy sources including natural gas, coal, nuclear, solar, wind, and biomass. The results of the analysis showed that the most economical sources of hydrogen are coal and natural gas with an estimated cost of 0.36-1.83 \$/kg and 2.48-3.17 \$/kg for each energy source, respectively. A kilogram of hydrogen has the approximate energy content of one gallon of gasoline; therefore the cost of hydrogen per kilogram is directly comparable to the gasoline cost per gallon. Consequently, hydrogen can be produced economically considering the recent cost of gasoline in the 2.00-4.00 \$/gal range.

Alternative sources of hydrogen had the highest estimated production costs with most estimates exceeding 4.00 \$/kg. However, there were several alternative studies that showed a promising future for alternative sources of hydrogen if advanced technologies are developed. For example, hydrogen from nuclear energy may be produced for a price as low as 1.84 \$/kg from a modular helium reactor with thermochemical hydrogen production. In contrast, the existing light-water reactors with electrolysis have a higher hydrogen production cost estimated to be between 4.36 and 7.36 \$/kg, which would not be considered a low cost energy source relative to recent gasoline prices. In addition, feedstock costs are increasing for traditional fossil-fuel plants while technology enhancements are decreasing the cost of alternative energy sources. Therefore, alternative fuel sources may become economical hydrogen sources relative to fossil fuels in the future

CHAPTER 3. AMMONIA PRODUCTION

The majority of the United States ammonia supply is currently produced by using natural gas. Recently, ammonia prices have been above 700 \$/t and even over 1,000 \$/t, which is much higher than the 200-400 \$/t price range seen throughout the 1990's. Natural gas has also increased in cost over the past few years and, as the main feedstock for ammonia production, is one of the major factors that is contributing to higher ammonia prices.

Presently, the major use of ammonia is as a fertilizer, which supplies nitrogen to plants, and as such it is an integral part of crop production. Further evidence of ammonia's importance is that when it is not used as a fertilizer then significantly lower crop yields result, which affects our ability to feed the population. Based on this widespread usage, a significant ammonia infrastructure already exists in many places. As one would expect, ammonia prices have an impact on food pricing and a low cost ammonia fertilizer supply is needed to keep food costs low throughout the world.

In addition to its use in food production, ammonia is also being considered as a potential replacement for fossil transportation fuels, similar in concept to the Hydrogen Economy. Ammonia, when used as an energy carrier and fuel, minimizes some of the barriers to the Hydrogen Economy while still providing all of the benefits. Ammonia consists of one atom of nitrogen and three atoms of hydrogen, therefore no carbon emissions are given off when ammonia is combusted or used in a fuel cell, just like hydrogen. The only products of ammonia combustion are water and nitrogen. Ammonia is also about 1.7 times more energy dense than liquefied hydrogen. As mentioned earlier, since ammonia is one of the most widely produced chemicals in the world, a significant infrastructure, including pipelines and large scale refrigerated storage facilities, already exists. This infrastructure along with experience in handling ammonia could help the growth of an Ammonia Economy.

Ammonia can be made from many different energy sources, which could help stabilize the ammonia price by allowing multiple technologies to compete for the lowest cost form of ammonia production. Unlike fossil fuels, which rely on a single, non-renewable source of

energy abundant only in a few places on earth, ammonia can be produced from local alternative energy sources.

The following analysis determines the cost of producing ammonia from conventional and alternative energy sources for use as both a fertilizer and transportation fuel. Cost estimates for the price of ammonia are given for ammonia production from natural gas, coal, nuclear, wind, solar, OTEC, and biomass. The analysis also includes estimates for the cost of ammonia plants along with details on general ammonia plant design for alternative energy sources. Finally, ammonia is compared to hydrogen based on the production cost of the two alternative transportation fuels.

3.1 Ammonia Synthesis Processes

More than 90% of the world ammonia production currently uses the Haber-Bosch synthesis process, which is named for Fritz Haber and Carl Bosch who developed the process in 1913 [45]. This method is based on combining hydrogen and nitrogen over an iron oxide catalyst. In order to increase the performance of the plants, Haber-Bosch synthesis has been performed with different variations in synthesis pressure, temperature, and catalysts. However, new technologies such as thermochemical and solid state synthesis processes are currently being developed to further decrease the cost and improve the efficiency of ammonia production. The following describes the conventional and potential new technologies available for ammonia synthesis.

3.1.1 Haber-Bosch Ammonia Synthesis

In most commercial plants, either steam reforming of methane or gasification of coal is used as the source of nitrogen and hydrogen gas for the Haber-Bosch synthesis loop (Figure 4). The nitrogen and hydrogen gas mixture, which is called synthetic gas, is first compressed to 120-220 bar, depending on the particular plant, before it enters the ammonia synthesis loop [46]. Only a fraction of the synthetic gas is converted to ammonia in a single pass through the converter due to thermodynamic equilibrium of the ammonia synthesis reaction shown in Equation 5.

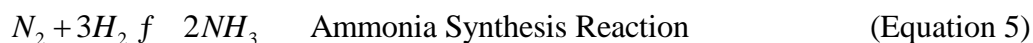

The remaining unreacted gas is passed through the converter again, forming a flow loop for the unreacted gas (Figure 4). The converter operates at temperatures between 380°C and 520°C [46], which is controlled by heating the feed gas along with the heat addition from the exothermic synthesis of ammonia (46.22 kJ/mol). The converter typically contains a catalyst of iron promoted with K_2O and Al_2O_3 to speed the reaction and to increase the amount of ammonia produced during each pass [46].

The gaseous ammonia and unconverted synthetic gas then enters the ammonia recovery portion of the synthesis loop. Refrigeration coolers decrease the temperature of the gas to -10°C to -25°C so that the ammonia condenses out of the mixture, thus leaving behind the unreacted synthetic gas [47]. Impurities in the synthetic gas from the steam reformation process, such as argon from the air and methane from the methanation process, are then purged from the mixture. Makeup synthetic gas is then added to the synthesis loop and combined with the remaining unconverted synthetic gas from the cooler. Since the gas is circulated through the synthesis loop by using a compressor, efforts are made to maintain a low pressure drop in the synthesis loop.

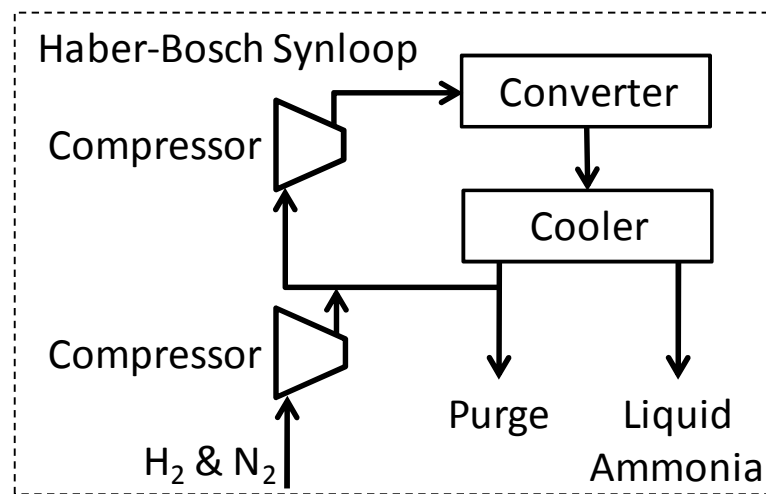

Figure 4: Flow diagram of Haber-Bosch synthesis loop showing major components

The Haber-Bosch process continues to be improved, mostly through changes in the catalyst and heat recovery. One catalytic improvement that is starting to be used commercially is a ruthenium-based catalyst instead of an iron-based catalyst [1]. An improved catalyst allows

more ammonia to be produced per pass through the converter at lower temperatures and pressures. As a result, less energy is consumed in the production of ammonia.

3.1.2 Thermochemical Ammonia Synthesis

The Haber-Bosch process has limitations due to an unfavorable thermodynamic equilibrium for ammonia synthesis, which results in low yields per pass through the converter. In addition, producing the hydrogen and nitrogen feedstock for the process is an energy intensive process. Gálvez et al. suggests a two-stage thermochemical process to decrease the energy requirement and cost of production [45]. The first step produces AlN and CO by reducing Al_2O_3 with nitrogen and a carbon source in an endothermic reaction. The AlN is then combined with water in an exothermic step to produce Al_2O_3 and ammonia with the Al_2O_3 then being reused in the first reaction. The process also produces CO, which could be used as a fuel for other purposes or converted to methanol [45].

3.1.3 Solid State Ammonia Synthesis

A new development in ammonia synthesis technology is solid state ammonia synthesis (SSAS). The system uses a solid state electrochemical process to produce ammonia from nitrogen, water, and electricity. The process described by Ganley et al. shows water being broken into oxygen and hydrogen with the hydrogen reacting with nitrogen to form ammonia [48].

The SSAS technology is ideally suited for renewable energy sources that produce electricity, such as wind and solar photovoltaic, since electrolyzers for hydrogen production and the Haber-Bosch synloop are eliminated with the SSAS system, resulting in several energy and economic benefits. According to Ganley et al, the SSAS process requires 7,000-8,000 kWh/ton- NH_3 , compared to 12,000 kWh/ton- NH_3 for an electrolyzer with a Haber-Bosch synloop [48]. The capital cost is roughly 200,000 \$/ton-day- NH_3 , which is significantly less than the 750,000 \$/ton-day- NH_3 estimate for an electrolyzer with a Haber-Bosch synloop system [48]. This technology is currently still being commercialized. However, the cost of producing ammonia is expected to be 347 \$/t based on 0.035 \$/kWh electricity [48].

3.2 Fossil Fuel Based Ammonia Synthesis Processes

Natural gas and coal are currently the two main feedstocks used for ammonia production; however both sources of energy are fossil fuels with limited availability. Currently, the proved reserves of natural gas and coal are expected to last 60 and 133 years, respectively, at the current rate of consumption [4].

3.2.1 Ammonia from Natural Gas

The production of ammonia from natural gas begins by producing hydrogen and nitrogen for the ammonia synthesis process (Figure 5). The natural gas is first cleaned by using a hydrodesulfurization process to remove the small amount of sulfur contained in the gas, which would damage the catalyst in the ammonia synloop. This process injects a small amount of hydrogen into the natural gas and then heats the gas to 400°C over a cobalt oxide or nickel oxide catalyst. Hydrogen sulfide is formed and then removed over a bed of zinc oxide to produce zinc sulfide and water [47].

Steam is then added to the sulfur-free natural gas to preheat the gas and to create a steam-to-carbon molar ratio of between three and four. The mixture then enters the primary reformer, which is a furnace with a nickel oxide catalyst, at a pressure of 25-40 bar. The reactants are heated to 750-850°C to provide the heat needed for the endothermic methane-steam reaction and CO shift reaction (Equation 1 and 2), which creates an equilibrium mixture of methane, carbon monoxide, carbon dioxide, and hydrogen gas leaving the primary reformer [47].

The mixture then enters the secondary reformer where air, which is compressed and preheated, is added. The oxygen from the air reacts with the hydrogen to raise the temperature in the reformer to 1,000°C, which further shifts the equilibrium of the methane-steam reaction to decrease the methane content to about 0.3% on a dry basis [47]. The amount of air added is controlled to provide a molar ratio of three hydrogen to one nitrogen, which is needed to produce ammonia.

The gas is cooled and used to generate steam before entering the shift conversion stage where the CO shift reaction (Equation 2) is used to decrease the amount of carbon monoxide in the mixture. At lower temperatures, the equilibrium mixture shifts to produce carbon dioxide and hydrogen from the carbon monoxide and water entering the shift conversion reactor.

Two stages are typically used, beginning with an iron oxide and chromium oxide catalyst at 350-500°C and followed by a copper oxide, zinc oxide, and alumina catalyst at 200-250°C [47]. Following this process, the carbon monoxide content of the gas is reduced to around 0.3% on a dry basis [47].

The carbon dioxide in the mixture is then removed to a level of less than 0.1% by using either the Benfield, Selexol, or MDEA process. The remaining trace amounts of carbon oxides (CO, CO₂) are then removed through methanation, which is where a nickel oxide catalyst at 250-350°C converts the carbon oxides to methane by using some of the hydrogen gas in the process. After this stage, less than 5 ppm of carbon oxides remain in the mixture, which is important to minimize problems with oxygen damaging the catalyst in the ammonia synthesis loop [47]. The mixture is then cooled to condense out the water and to capture heat. The nearly pure mixture of hydrogen and nitrogen is then pressurized as it enters the synloop, where the gas is converted into ammonia.

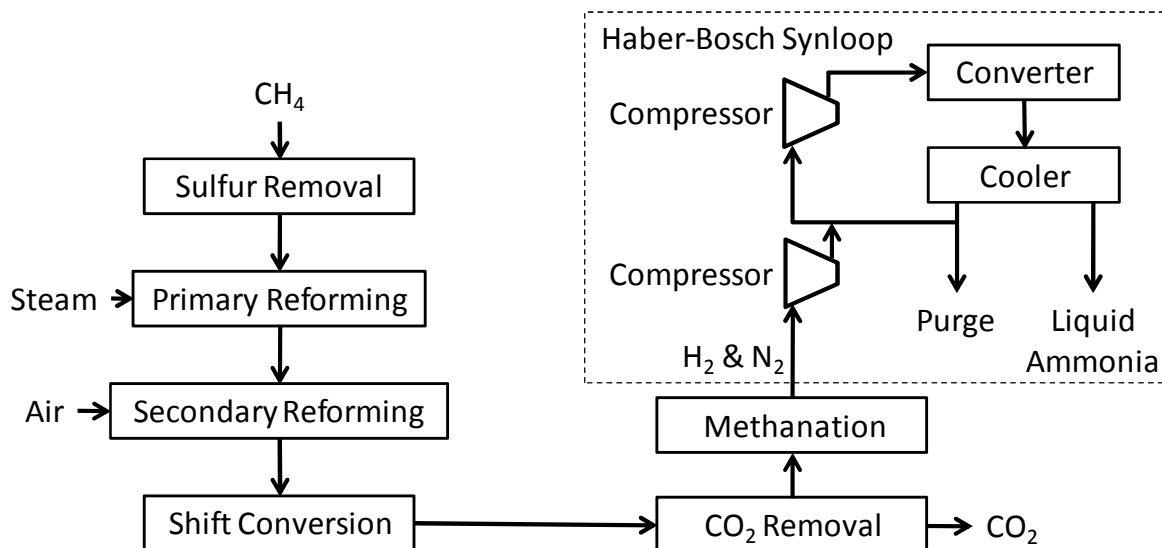

Figure 5: Haber-Bosch ammonia synthesis with natural gas

3.2.1.1 Economic Studies

For the complete synthesis of ammonia from natural gas, Appl provides a cost of 172.50 \$/t for an 1,800 t/day plant in 1998 dollars [1]. The cost estimate assumes natural gas cost is 2.80 \$/MMBtu. If this cost is updated to 10.00 \$/MMBtu and adjusted for inflation to 2007 dollars, the cost of ammonia is 497.55 \$/t with an expected plant cost of 339 M\$.

3.2.2 Ammonia from Coal

Coal gasification is used to produce synthetic gas as the input to the Haber-Bosch process. This gasification process involves an exothermic reaction of coal with a mixture of oxygen and steam to produce synthetic gas, mainly consisting of carbon monoxide and hydrogen [1]. Significant quantities of water, carbon dioxide, and methane can also be found in the synthetic gas products. The synthetic gas is processed by using the methane-steam reaction and CO shift reaction (Equation 1 and 2) to shift the carbon monoxide and methane into hydrogen. The gas also goes through several treatments to remove carbon dioxide and trace substances in the gas stream, such as particulates and sulfur and nitrogen compounds [3]. The hydrogen and nitrogen mixture is then fed to the Haber-Bosch synloop for production of ammonia.

3.2.2.1 Economic Studies

Appl provides a cost for ammonia from coal of 270.60 \$/t in 1998 dollars based on an 1,800 t/day plant with coal at a cost of 1.50 \$/MMBtu [1]. Adjusted for inflation, the price of ammonia would be 366.96 \$/t in 2007 dollars with the estimated cost of such a plant being 678 M\$ [1].

3.2.2.2 Existing Plants

Coal gasification is a mature and well known technology in that there are coal gasification plants throughout the world producing ammonia. For example, two ammonia plants within the United States produce ammonia from gasification of coal and petroleum coke. China currently uses coal gasification for the majority of its ammonia production.

3.2.2.2.1 The Great Plains Synfuels Plant

The Great Plains Synfuels Plant is located in Beulah, North Dakota. The plant began operation in 1984 after the energy crisis of the 1970's spurred the development of technologies to reduce reliance on Middle East oil. The plant primarily produces synthetic natural gas, which is distributed throughout the United States via pipeline, but it also produces ammonia with the addition of a 1,000 t/day ammonia plant in 1997 [49].

The Great Plains Synfuels Plant currently sequesters carbon dioxide by selling it for use in enhanced oil recovery, which is where carbon dioxide is injected into oil fields resulting in

recovering oil that would otherwise remain in the ground. The carbon dioxide and hydrogen sulfide removed from the gasified coal by the Rectisol Process is compressed and transported via pipeline to Williston Basin oil field [49]. The plant produces 12,466 t/day of carbon dioxide, and about 4,934 t/day are sold for oil recovery [49].

3.2.2.2 Coffeyville Resources Nitrogen Fertilizers LLC

The Coffeyville Resources Nitrogen Fertilizers Plant is located in Coffeyville, Kansas and began commercial operations in 2000. It does not use coal, but it uses modern Texaco gasifiers to gasify petroleum coke in a similar process, with the plant producing an average ammonia output of 900 t/day in 2006 [50].

3.2.2.2.3 China

China is the world's largest ammonia producer, and coal provides 70% of the ammonia capacity in the country [51]. Currently, atmospheric gasification, Texaco slurry gasification, and Lurgi dry-bed gasification are used commercially in China [51].

The atmospheric gasification design uses air instead of oxygen in the gasifier. The gasifier costs less and is simpler, but it is not as efficient and can only use anthracite and coke as a feedstock. Lurgi gasifiers have been used since the 1950's, but only two ammonia production plants use the technology [51]. The rest of the Lurgi gasifiers are used to produce town gas, which is sold to municipalities and consumers.

The plants that use the Texaco gasifier are the newest coal-to-ammonia plants in China. There are currently four plants, with ammonia production capacity ranging from 80,000 to 300,000 t/year, which is equivalent to the gasification of coal at a rate of 350 to 900 t/day [51]. Several additional plants that use the Texaco gasifiers are currently under construction [52].

3.3 Alternative Energy Based Ammonia Synthesis Processes

Fossil fuel resources are limited and other energy sources are needed for both environmental and economic reasons. Alternative fuels include wind, solar, nuclear, hydroelectric, OTEC, and any of several other non-fossil fuel sources of energy that do not produce greenhouse gases directly through the energy conversion process. Most of these technologies are still

more costly than fossil fuel energy sources, but the relative cost of alternative fuels is decreasing through technological improvements and increases in fossil fuel costs. The following describes studies that use alternative fuels to produce ammonia and the associated costs.

3.3.1 Ammonia from Wind Energy

Wind to ammonia systems produce ammonia through the use of electricity from wind turbine generators, which are usually large horizontal-axis wind turbines mounted on a tower. Wind turbines are commercially available in sizes up to about 2.5 MW of nameplate capacity for on-shore applications and even larger machines can be found in off-shore applications. The electrical output of the wind turbine is highly dependent on wind speed, resulting in a high variability in electrical energy production. The basic ammonia synthesis design is to use an electrolyzer to produce hydrogen from water and an air separation unit to obtain nitrogen from air, both of which are combined in a Haber-Bosch synthesis reactor for production of ammonia.

3.3.1.1 Economic Studies

The University of Minnesota is in the process of studying the production of ammonia from wind power. The system will use a 1.65 MW Vestas V-82 wind turbine to provide electricity to an electrolyzer, thus producing hydrogen from water. The hydrogen will then be combined with nitrogen from the air in a reactor by using a modified Haber-Bosch process. The facility is expected to be operational in the fall of 2008. The results of the research will provide data on energy efficiency, water usage, cost, economics, and operation and maintenance of a small-scale wind-to-ammonia plant. The cost of ammonia from the facility is estimated to be between 660 \$/t and 1,320 \$/t [53], which is higher than both coal and natural gas ammonia sources.

3.3.2 Ammonia from Ocean Thermal Energy Conversion

Ocean Thermal Energy Conversion (OTEC) is a solar-based energy source utilizing the temperature difference between the ocean surface and deep ocean waters. Near the equator, solar energy warms the top 50-100 m of ocean to a temperature of 27-30°C while ocean water at a depth of 1,000 m remains at or below 5°C [54]. The advantage of using OTEC is

the constant availability of the renewable resource during each and every day and hour of the year, unlike other renewable energy resources, such as wind and solar, which tend to have a cyclical and unpredictable nature of energy production.

To extract the energy, a vapor-power cycle is constructed by using the hot and cold heat reservoirs of ocean water. Warm surface water is passed through a heat exchanger to boil a liquid with a low boiling point, such as ammonia, propane, or fluorocarbons, which is then passed through a turbine to drive an electric generator, similar to a conventional steam Rankine cycle power plant. The fluid leaving the turbine is condensed in another heat exchanger by using the cold water extracted from deep in the ocean. To repeat the cycle, the condensed working fluid is pumped back to the first heat exchanger where the warm ocean surface water once again boils the liquid for use in the turbine.

One of the problems with OTEC power generation is the transportation of the energy generated to the end users. Storing the generated energy in chemical form, such as ammonia, may help solve this problem and make the technology feasible. Avery et al. suggested such a design in 1985, consisting of a 325 MW net electrical output OTEC plant producing ammonia at a rate of 1,000 t/day [54]. The plant would distill and electrolyze sea water to produce hydrogen that can then be combined with nitrogen, separated from air, to make ammonia. The ammonia would then be cooled and stored onboard the OTEC plant before being transported to land via tankers and used as either a transportation fuel or in the ammonia fertilizer industry [54].

The technology to construct a commercial power plant was verified in a test of MINI-OTEC in 1979 near Keahole Point, Hawaii. MINI-OTEC was a small, closed loop system that used ammonia as the working fluid, and in addition, was the first at sea plant to produce net power. The plant generated 50 kW of electrical energy during operation. However, it consumed 21.3 kW to power the seawater pumps, although additional losses in the system reduced the net power output to 17.3 kW [55]. The MINI-OTEC plant produced little power; however it did prove the concept of using OTEC to generate a net amount of electricity.

The ability of OTEC to produce a net amount of power was further supported in a paper by Avery et al. in 1999, which stated that a 46 MW pilot plant needs to be built to further test full scale feasibility [56]. The proposed 1,100 t/day, 365 MW full-scale plant would provide the motor vehicle fuel equivalent of 150,000 gal-gasoline/day. Approximately 2,000 of these plants would be needed to supply all of the energy needed by automobiles in the United States, which would result in a OTEC facility spacing of 175 km throughout the tropical ocean [56]. The closest spacing recommended by Avery et al. for such facilities is 45 km, which would equate to harnessing 0.1% of the solar energy striking the ocean within 10 degrees of the equator [56].

3.3.2.1 Economic Studies

A recent study by Ryzin et al. proposed the construction of a new facility and estimated costs by using values of equipment available in 2005. The 100 t/day of equivalent hydrogen production plant costs 886.7 M\$ and could produce ammonia for a cost of 554 \$/t delivered to Tampa, Florida in 2007 dollars [57]. The ammonia production rate, which was not specified but has been calculated based on the hydrogen output, is about 563 t/day. The study also noted that if the 1.9 ¢/kWh production tax credit for renewable energy production was applied to the facility, then the cost of ammonia would be 378 \$/t [57]. As noted previously, large-scale OTEC plants have not been built or operated, and therefore additional costs may be encountered if OTEC technology is commercialized.

3.4 Ammonia Production from Hydrogen

The majority of the ammonia synthesis plants in the United States use natural gas as a feedstock that is passed through a steam methane reformer to produce pure hydrogen, which is then fed to the Haber-Bosch synthesis loop. Any method that produces pure hydrogen could potentially be used as the input to the Haber-Bosch process, thus eliminating the use of natural gas.

Many hydrogen-production studies have already been described in Chapter 2, which provides data on the cost and size of various hydrogen production facilities (Table 7). To take the information one step further, the cost for the various hydrogen production methods has been converted to a cost for ammonia by using the appropriate cost indexes, process efficiencies,

capital costs, and reasonable economic assumptions. The following description is intended to make the methods and assumptions used in this analysis transparent so others can adjust the results if the use of other parameters is desired.

3.4.1 Ammonia Synthesis System Components

The results shown in Table 7 provide cost information for hydrogen in 2007 dollars and a hydrogen plant size in kilograms of production per day. For the analysis in this chapter, it is assumed a Haber-Bosch ammonia synthesis loop (synloop) can be attached to the hydrogen facility to convert the hydrogen into ammonia. This synloop needs a stoichiometric flow of hydrogen and nitrogen to operate, with the nitrogen being supplied by separating nitrogen from air with an air separation unit (ASU). It is assumed the output from the hydrogen production process is constant, thus providing a constant input to the ammonia plant.

3.4.1.1 Electrolyzers

Electrolysis is required to produce hydrogen from electricity, which is a process that uses an electrolyzer to break water into hydrogen and oxygen gas by passing electricity between two electrodes. Oxygen is produced at the anode, and hydrogen is produced at the cathode. Most electrolyzers available today are of the alkaline type, which use a solution of potassium hydroxide in water to act as a conductor. Proton exchange membrane (PEM) electrolyzers are another electrolysis technology that uses a membrane to transfer the proton, eliminating the requirement of an electrolytic solution and potentially increasing the efficiency.

3.4.1.2 Air Separation Unit

Nitrogen is obtained from air through the use of an air separation unit (ASU), which uses a combination of compression, cooling, and expansion to separate the nitrogen, oxygen, and other compounds from air. A typical ASU intakes atmospheric air and first filters it to remove unwanted particles and compounds. The air is then compressed to about 6 bar [58]. The heat from the compression process is removed and the compressed air is cooled to around -180°C and then expanded to further reduce the temperature [58]. The cool air is then fed into a separation column. The boiling point of oxygen and nitrogen are -183°C and -196°C , respectively [58]. The oxygen liquefies at the separation column temperature and settles to the bottom while the nitrogen rises to the top of the column [58].

3.4.2 Ammonia Synthesis from an Energy Source

The diagram in Figure 6 shows how different energy sources can potentially be used to produce ammonia by using Haber-Bosch ammonia synthesis. For all energy sources, the ultimate product desired is a stoichiometric mixture of hydrogen and nitrogen that can be fed to the synloop for conversion to ammonia. The method to obtain the mixture depends on the energy source and technology used.

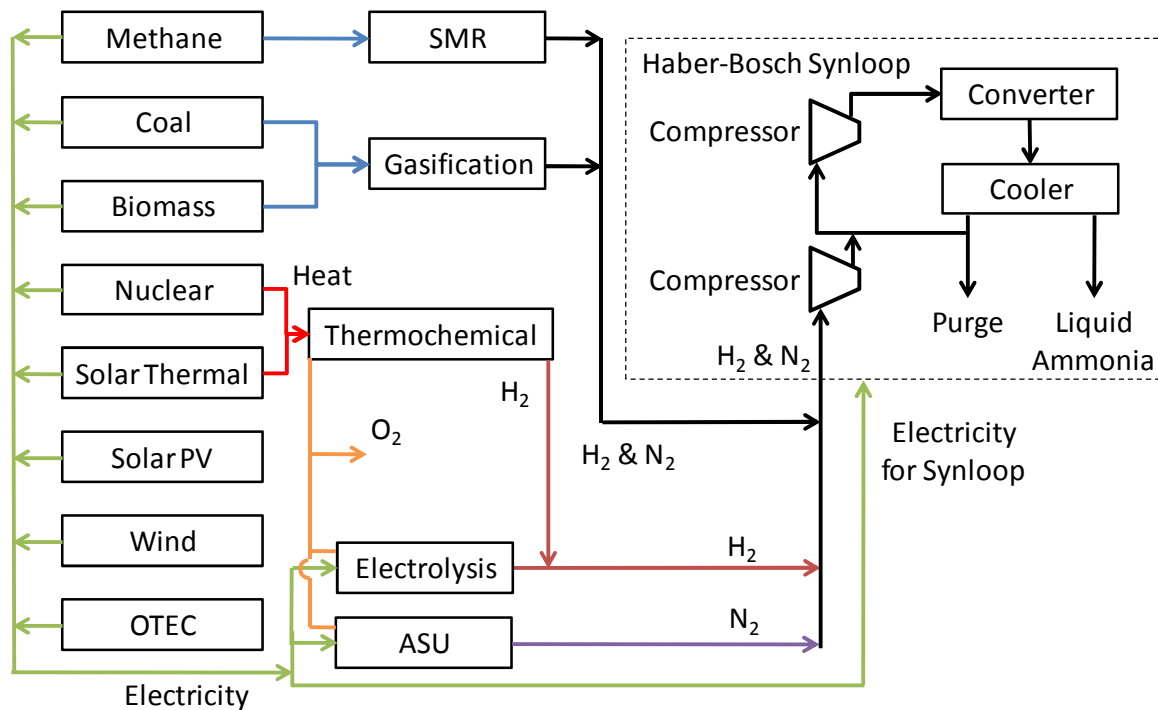

Figure 6: Diagram of methods to produce ammonia from several energy sources

All of the energy sources shown in Figure 6 can produce electricity to power an electrolyzer, air separation unit (ASU), and the Haber-Bosch synloop. The electrolyzer and ASU would supply the hydrogen and nitrogen gas mixture required for ammonia synthesis. The end product from this method of production from all energy sources would be pure oxygen and ammonia.

Obtaining hydrogen by electrolysis is not the most economical or energy efficient option for energy sources that are hydrocarbon based, such as natural gas, coal, and biomass. For each of these sources, it is more efficient to use steam methane reforming (SMR) or gasification to obtain hydrogen from the hydrocarbon chain. In addition, if the amount of air added in the

secondary reformer is properly controlled, a mixture of synthetic gas with the correct ratio of hydrogen and nitrogen is supplied to the synthesis loop, which eliminates the need for an ASU. In summary, a gasification or SMR process would be able to obtain more energy from the primary feedstock and produce ammonia at a lower cost compared to using an electrolyzer and ASU for synthetic gas production.

For alternative energy sources that provide high-temperature heat and have no carbon source, such as nuclear and solar thermal, a thermochemical process could be used to produce hydrogen instead of electrolysis. Using a thermochemical approach for hydrogen production is a lower cost and more efficient method than electrolysis for large-scale concentrating solar and nuclear facilities, which are high temperature heat sources. Electricity would still have to be generated, possibly by using waste heat or other energy recovery methods, to power the ASU and synloop.

The solar photovoltaic, wind, and OTEC energy sources shown in Figure 6 are not hydrocarbon based and are low-temperature; therefore electrolysis is required for hydrogen production. Tidal, wave, geothermal, and other alternative energy resources that produce electricity would also require electrolysis for hydrogen production. These energy sources all require the use of an air separation unit to obtain nitrogen from the air and, in addition, some of the electricity produced must be used to power the synloop.

3.4.3 Ammonia Synthesis from a Hydrogen Source

The analysis in this chapter uses the hydrogen-production information from Table 7. Therefore, a modified system design is used for ammonia production as shown in Figure 7. This design assumes hydrogen is obtained at a given cost and production rate from each energy source, an ASU is used to produce the nitrogen for ammonia synthesis, and a gas turbine fueled by hydrogen is used to generate electricity for both the ASU and ammonia synthesis processes.

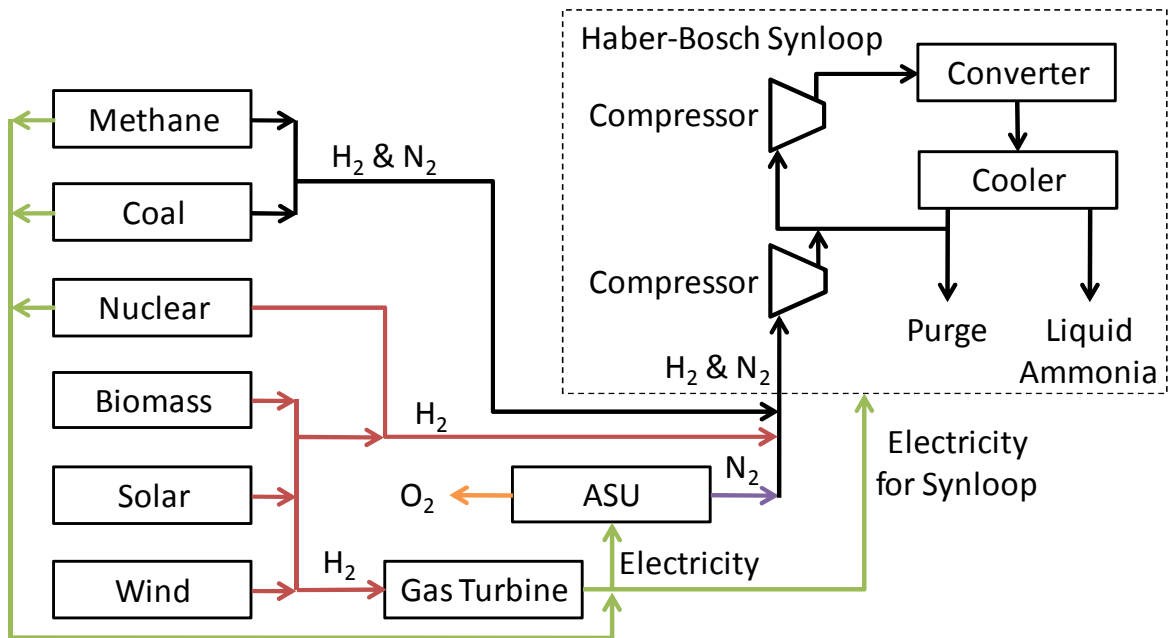

Figure 7: Ammonia production from a hydrogen source

3.4.3.1 Gas Turbine and Air Separation Unit

The gas turbine adds an inefficiency to the ammonia synthesis process since energy is lost in the conversion of hydrogen to electricity. A real plant may use electricity from the power grid or possibly capture waste heat from the hydrogen production process to drive a power cycle to produce electricity, depending on the most efficient and economical design. The gas turbine is used in this analysis to eliminate the intermittency of the alternative energy sources and to properly account for costs involved with the production of ammonia from each energy source.

Alternative energy sources, such as wind and solar, have a highly variable output and a low capacity factor. Therefore, including a gas turbine and a small amount of hydrogen storage allow the ammonia synloop to operate at a nearly constant output by providing a continuous supply of hydrogen to the synloop and to the electricity-producing gas turbine. In contrast, using electricity from the variable alternative energy source could result in undesirable shutdowns of the synloop and ASU system during times when there is little renewable electricity available. This variable energy source would also result in an oversized synloop operating at a low capacity factor, which would increase production cost.

Cost accounting for each individual resource also requires the use of the gas turbine in this analysis. In contrast, if grid electricity was used, an appropriate cost would have to be applied, and the source of that electricity may not be from the same energy source as the hydrogen. Using a gas turbine guarantees that the primary energy source supplying the hydrogen is also supplying the electricity to the synloop. Consequently, the ammonia production cost calculated for a specific energy resource includes all of the primary energy needed for ammonia production from that resource.

The use of an ASU with natural gas and coal as hydrogen sources is assumed to be unnecessary due to the gasification process. Natural gas, coal, and nuclear energy sources do not need a gas turbine since waste heat or electricity to power the synloop is already available from the hydrogen production process. These sources also provide a constant output, unlike wind and solar, and can provide electricity consistently to the synloop. Plant differences are accounted for later in the plant efficiency and cost calculations.

3.4.3.2 Conversion Efficiency and Plant Size

Converting hydrogen into ammonia requires an electrical energy input to operate the synloop and ASU. As presented by Gosnell in 2005, the most recent number for synloop energy use is 0.390 kWh/kg-NH₃ [59]. This energy use number includes both the synloop and ASU energy use.

Hydrogen production information from Chapter 2 is used herein as the energy source for the synloop and ASU operation as well as the hydrogen feedstock (Table 7). The energy needed to run the equipment must be in the form of electrical energy with hydrogen being converted to electricity by using a simple cycle gas turbine with a heat rate of 9,750 Btu/kWh, which is equivalent to a thermal efficiency of 35% [60]. This efficiency value is based on actual gas turbines used for power generation with natural gas as a feedstock. Therefore, the hydrogen requirement to run the synloop and ASU is 33.44 kg-H₂/t-NH₃. If the gas turbine is not needed, such as for nuclear, coal, and natural gas plants, the equivalent amount of hydrogen is 11.70 kg-H₂/t-NH₃.

Table 8 gives the overall conversion efficiency from hydrogen to ammonia for designs with and without a gas turbine. The given conversion efficiency is the amount of hydrogen in one

tonne of ammonia divided by the total hydrogen input to run the process. The conversion efficiency is 84.2% for the design with a gas turbine, and 93.8% for the design without a gas turbine. This efficiency is used to determine the output of an ammonia plant based on the output of the hydrogen plant. The actual plant size is determined by dividing the plant output by the capacity factor to give the rated plant output, which is used for cost scaling purposes.

Table 8: Conversion efficiency from hydrogen to ammonia

	Gas Turbine Required	Electricity from H ₂ Plant
Energy Requirement (kWh/tonne NH ₃)	390	390
Electricity Production LHV Efficiency	35%	100%
Equivalent H ₂ Requirement (kg/tonne NH ₃)	33.44	11.70
Total H ₂ Requirement per tonne NH ₃	211.01	189.27
Conversion Efficiency (%)	84.2%	93.8%
LHV Energy Efficiency (%)	73.4%	81.8%

The lower heating value efficiency of the process has been calculated to be about 10% lower than the hydrogen conversion efficiency for both cases (Table 8). The comparison of energy efficiency takes into account the heating value of both ammonia and hydrogen. Per unit of hydrogen, the heating value of ammonia is lower than that of hydrogen due to the endothermic reaction required to break ammonia apart into hydrogen and nitrogen.

3.4.3.3 Plant Capital Cost

Ammonia production facilities are increasing in cost due to cost increases in raw materials such as steel and concrete. The most recent construction cost for a natural gas ammonia production facility is 740 \$M for a 2,200 t/day facility in 2007 dollars, of which the cost of the Haber-Bosch synloop alone is about one-third of the cost of an entire plant [61]. The total cost of the synloop used in this study is assumed to be 245 M\$ for a 2,200 t/day facility.

The plant designs requiring a source of pure nitrogen also require an ASU, with the ASU cost being about one-fourth of the total capital required for an entire conventional ammonia plant [61]. The ASU plant cost used in this study is therefore 185 M\$. In summary, the total plant cost for the synloop and ASU combined is 430 \$M for a 2,200 t/day ammonia production facility that uses pure hydrogen as a feedstock and extracts nitrogen from the air.

The production of electricity from hydrogen requires a gas turbine. The capital cost of a simple-cycle gas turbine with 46.6 MW of output was found to be 680 \$/kW_{Peak}, or 31.69 M\$ [60]. For the 2,200 t/day ammonia plant, a gas turbine would be needed with 35.75 MW of capacity. Using a scaling factor of 0.65, the cost of the turbine would thus be 26.67 M\$. Operating and maintenance costs were also given as 13 \$/kW_{Peak} for each year of operation [60]. Therefore, the 2,200 t/day ammonia plant would have operating and maintenance costs of 464,750 \$/year just for the gas turbine.

3.4.3.4 Economic Assumptions

Economic parameters have been defined for the ammonia synthesis plant (Table 9) and used in an economic model to determine capital cost. The ammonia synthesis plant is assumed to be constructed over a period of three years. The construction interest of 8.21% assumes an interest rate of 8.0% during construction with construction costs divided equally between each year of construction. The interest is added to the plant capital cost to give the total plant investment when the plant begins operating. The operating and maintenance costs are assumed to be 4% of the overnight capital cost for the Haber-Bosch synloop and ASU; the operating and maintenance cost for the gas turbine is based on the size of the gas turbine and calculated accordingly.

The plant is assumed to be financed with a debt to equity ratio of 0.6, a real discount rate of 8.0%, and a 20 year debt repayment period. The return on equity for the investor is 15% and taxes are assumed to be 40% for federal and state combined. Working capital for the plant is assumed to be three months of revenue from ammonia sales. The plant is assumed to be depreciated on a 20 year schedule by using the MACRS method. Total assumed plant life is 30 years with the salvage value assumed equivalent to the decommissioning cost, and the general inflation over the entire plant life is at an assumed three percent.

Table 9: Economic assumptions for ammonia synthesis facility

Construction Period	3 years
Interest During Construction	8.21%
Plant Capacity Factor	90%
O&M Costs	4% overnight capital
Return on Equity	15%
Debt/Equity Ratio	0.6
Real Discount Rate	8.0%
Depreciation	20 years MACRS
Federal & State Tax	40% combined
Plant Life	30 years
Debt Repayment Period	20 years
General Inflation	3.00%
Working Capital	3 months revenue
Salvage value equivalent to decommissioning	

3.4.3.5 Specific Capital Cost of Ammonia Synthesis

Using the above economic assumptions, an income and cash flow statement was developed for the ammonia production facility over the entire plant life. The cost of the hydrogen feedstock is already known from the hydrogen production in Chapter 2 (Table 7). Therefore, the purpose of the income and cash flow statement is to determine the additional cost of capital per tonne of ammonia produced.

The result for the 2,200 t/day plant is a capital charge of 141.65 \$/t including the air separation unit and gas turbine. Designs not requiring an air separation unit or gas turbine decrease this cost to 76.50 \$/t. Costs for all design options are shown in Table 10.

Table 10: Specific capital cost for ammonia synthesis for designs with and without ASU and gas turbine for a 2,200 t/day synthesis plant

	Ammonia Synthesis Capital Charge (\$/tonne)	
	With Gas Turbine	Without Gas Turbine
With ASU	134.23	141.65
Without ASU	76.48	84.27

The capital charge in Table 10 is the cost of conversion at the facility and does not include the feedstock cost. This cost can be scaled to other size plants by using an economy of scale sizing exponent of 0.65 [61]. Approximate capital costs for multiple size facilities are given in Table 11 on a cost-per-tonne of ammonia basis as a function of plant size. Costs are given for plants with and without an ASU and gas turbine and also for the individual components of the plant.

Table 11: Specific capital cost per tonne of ammonia and total plant cost based on plant size and use of ASU

Plant Size (t/day)	Ammonia Capital Charge	Ammonia Capital Charge	Haber Bosch		Gas Turbine Capital (M\$)	Total Capital (M\$)
	with ASU & Gas Turbine (\$/t)	without ASU & Gas Turbine (\$/t)	Synloop Capital (M\$)	Air Separation Unit Capital (M\$)		
10	935.55	505.11	7.4	5.6	0.0	12.9
20	734.02	396.30	11.5	8.7	0.0	20.3
50	532.63	287.57	20.9	15.8	0.0	36.7
100	417.90	225.63	32.9	24.8	0.0	57.7
200	327.87	177.02	51.6	38.9	0.0	90.5
300	284.50	153.60	67.1	50.7	0.0	117.8
400	257.25	138.89	80.9	61.1	0.0	142.0
600	223.21	120.51	105.3	79.5	0.0	184.8
800	201.83	108.97	126.9	95.9	0.0	222.8
1000	186.67	100.78	146.8	110.8	0.0	257.6
1200	175.13	94.55	165.2	124.8	0.0	290.0
1400	165.93	89.59	182.6	137.9	0.0	320.5
1600	158.35	85.50	199.2	150.4	0.0	349.6
1800	151.96	82.04	215.0	162.4	0.0	377.4
2000	146.46	79.07	230.3	173.9	0.0	404.2
2200	141.65	76.48	245.0	185.0	0.0	430.0
2400	137.40	74.18	259.3	195.8	0.0	455.0
2600	133.61	72.14	273.1	206.2	0.0	479.3
2800	130.19	70.29	286.6	216.4	0.0	503.0
3000	127.08	68.61	299.7	226.3	0.0	526.0
3200	124.24	67.08	312.6	236.0	0.0	548.6
3400	121.63	65.67	325.1	245.5	0.0	570.6

3.4.4 Cost of Ammonia from Conventional and Alternative Energy Sources

The selling price of ammonia was calculated based on the capital charge for production and the cost of hydrogen as a feedstock for the synthesis process. The actual ammonia output of the plant has been divided by the capacity factor to give the appropriate plant size, which is used for plant sizing calculations and associated costs. For studies that did not state a design capacity, an appropriately sized output was assumed based on similar designs found in other studies. The capital cost for the facility is calculated by using the same scaling factor. All of these economic numbers are given for each study in Table 12. Several studies that were based only on ammonia production already described in this chapter are also included in Table 12. The plant size and costs are reported as found in their respective studies with adjustments for inflation so that all values can be reported in the same time period.

Table 12: Calculated cost of ammonia from hydrogen sources

Study	Energy Source	Process	Air Separation		Ammonia Plant Size (t/day)	Haber Bosch		Haber Bosch Capital (\$/t)	Ammonia RSP (\$/t) (2007)
			Unit	Gas Turbine		Synloop Capital (M\$)	Total Capital (M\$)		
Appl	Natural Gas	Steam Methane Reforming	No	No	1800	a	337	a	495
Gray and Tomlinson	Natural Gas	Steam Methane Reforming	No	No	1387	182	276	90	560
Penner	Natural Gas	Steam Methane Reforming	No	No	1400*	183	b	90	689
Rutkowski	Natural Gas	Steam Methane Reforming	No	No	2004	231	433	79	521
Rutkowski	Natural Gas	Steam Methane Reforming with Sequestration	No	No	2004	231	485	79	561
Ganley et al.	Electricity	Solid State Ammonia Synthesis	No	No	†	a	b	a	347
Petri et al.	Nuclear	Electrolysis-Base Load	Yes	No	6	9	b	1068	1,894
Petri et al.	Nuclear	Electrolysis-Off Peak	Yes	No	6	9	b	1068	2,462
Richards et al.	Nuclear MHR	Sulfur-Iodine Thermochemical	Yes	No	3500*	581	b	114	462
Schultz	Nuclear MHR	Sulfur-Iodine Thermochemical (Low Efficiency)	Yes	No	3422	573	2681	115	613
Schultz	Nuclear MHR	Sulfur-Iodine Thermochemical (High Efficiency)	Yes	No	4244	659	3137	107	570
Giaconia et al.	Solar & NG	Sulfur-Iodine Thermochemical	Yes	Yes	455	154	1635	246	1,835
Glatzmaier et al.	Solar	Photovoltaic Electrolysis (\$5/W)	Yes	Yes	7	11	65	1041	5,951
Glatzmaier et al.	Solar	Photovoltaic Electrolysis (\$0.75/W)	Yes	Yes	7	11	23	1041	2,262
Glatzmaier et al.	Solar	Dish Stirling Electrolysis	Yes	Yes	7	10	32	1053	3,266
Glatzmaier et al.	Solar	Power Tower Electrolysis	Yes	Yes	331	126	750	275	1,637
Gray and Tomlinson	Solar	Photovoltaic Electrolysis	Yes	Yes	1866	386	5949	150	1,426
Kolb et al.	Solar	Power Tower Electrolysis	Yes	Yes	202	91	512	327	1,403
Kolb et al.	Solar	Sulfuric acid/hybrid Thermochemical	Yes	Yes	490	162	549	240	830
Bockris & Veziroglu	Wind	Electrolysis	Yes	Yes	5*	8	b	1192	1,931
Levene et al.	Wind	Electrolysis (Near Term)	Yes	Yes	5	9	12	1171	2,342
Levene et al.	Wind	Electrolysis (Long Term)	Yes	Yes	5	9	9	1171	1,650
Levene	Wind	Electrolysis Without Electricity Coproduction	Yes	Yes	263	108	669	298	1,727
Levene	Wind	Electrolysis With Electricity Coproduction	Yes	Yes	263	108	675	298	1,693
Reese	Wind	Electrolysis (Low Estimate)	Yes	Yes	5*	a	b	a	660
Reese	Wind	Electrolysis (High Estimate)	Yes	Yes	5*	a	b	a	1,320
Ryzin et al	OTEC	OTEC	Yes	Yes	563	a	882	a	554
Mann	Biomass	Gasification	Yes	Yes	736	211	379	208	627
Padró and Putsche	Biomass	Pyrolysis (Low Estimate)	Yes	Yes	384	138	212	261	570
Padró and Putsche	Biomass	Pyrolysis (High Estimate)	Yes	Yes	14	16	20	828	1,369
Padró and Putsche	Biomass	Gasification (Low Estimate)	Yes	Yes	1022	261	503	185	488
Padró and Putsche	Biomass	Gasification (High Estimate)	Yes	Yes	10	13	22	922	1,519
Appl	Coal	Coal Gasification Without Sequestration	No	No	1800	a	674	a	365
Gray and Tomlinson	Coal	Coal Gasification With Sequestration	No	No	1650	203	766	85	322
Gray and Tomlinson	Coal	Coal Gasification Without Sequestration	No	No	1817	216	711	82	281
Gray and Tomlinson	Coal	Advanced Gasification With Sequestration	No	No	2080	236	1611	78	147
Kreutz et al.	Coal	Coal Gasification With Sequestration	No	No	4524	391	1591	59	317
Kreutz et al.	Coal	Coal Gasification Without Sequestration	No	No	4524	391	1530	59	276
Rutkowski	Coal	Coal Gasification With Sequestration	No	No	1626	201	814	85	432
Rutkowski	Coal	Coal Gasification Without Sequestration	No	No	1499	191	680	87	372

* Plant size not given, but estimated based on similar studies a Ammonia based study b Hydrogen study did not contain capital cost information † Study did not provide data for this value

The cost of ammonia varies based on the energy resource as shown in Table 12. The lowest cost source is from coal with a cost range of 147-432 \$/t. Natural gas is slightly higher with a cost of 395-689 \$/t mostly due to the high natural gas feedstock cost. Both natural gas and coal have a lower production cost than the recent ammonia prices, which have been above 700 \$/t.

Ammonia from nuclear power may also be competitive depending on the specific technology that is used for hydrogen production. For example, if a modular helium reactor is used with thermochemical hydrogen production, the cost of ammonia is as low as 462 \$/t. However, if a conventional light-water reactor is used with base-load electrolysis for hydrogen production, the cost of ammonia may be as high as 1,894 \$/t.

Biomass can be used to produce ammonia for a cost of 488-1,855 \$/t. However, ammonia produced from a food source may not be desirable since food is needed to feed the human population. If an alternative source of biomass feedstock is used, such as municipal solid waste, ammonia production from biomass could be produced economically without competing with food supplies.

The OTEC cost is estimated to be 554 \$/t, however, this cost cannot be confirmed because no large scale OTEC facilities are in existence. However, if this cost could be achieved, then this cost is competitive with current ammonia prices over 700 \$/t and is within the range of current ammonia prices from natural gas. Wind and solar had the highest ammonia production cost with a range of 660-2,342 \$/t and 830-5,951 \$/t, respectively.

In addition to competitive costs, there are additional considerations that may affect which energy sources are chosen for ammonia synthesis. Coal currently faces environmental issues, and as mentioned previously OTEC technology has not been used on a large scale. Solid state ammonia synthesis, although one of the lowest cost technologies found in this study with a cost of 347 \$/t, is still being developed and is not commercially available. Other low-cost sources are nuclear, but all of the low-cost ammonia-producing designs that use nuclear energy are based on the high temperature modular helium reactor and no reactors have been

constructed based on this design. Wind and solar technologies have the highest production cost, but since neither has a feedstock cost, the technology may become cheaper relative to other technologies as fossil fuel energy costs increase.

3.4.5 Comparison to Fossil Fuels

For ammonia or hydrogen to compete as a transportation fuel, the cost will have to be comparable or lower than the cost of existing transportation fuels. Table 13 shows a comparison between hydrogen, ammonia, and gasoline. The costs are compared between hydrogen and ammonia on a cost per gigajoule basis by using lower heating values for both fuels. Two columns show the gallon-of-gasoline equivalent (GGE) value for both hydrogen and ammonia, which is the cost of the respective amount of fuel required to equal the energy content of a gallon of gasoline on a lower heating value basis.

The costs shown in Table 13 are all relative to the hydrogen and ammonia cost since they are directly derived from the calculated prices by using the lower heating value of the respective fuel. Ammonia will cost more than hydrogen on an energy content basis due to the additional processing and capital equipment required to synthesize ammonia from hydrogen. The only exception would be if alternative technologies for ammonia synthesis, with lower energy and capital requirements, are commercialized to produce ammonia directly from water and nitrogen. An example of such a process is solid state ammonia synthesis, which would eliminate the intermediate step of producing hydrogen.

Comparing the cost between gasoline and the alternative fuels of hydrogen and ammonia shows that these alternative fuels can compete with gasoline on an economic basis. If the alternative fuel cost in GGE in Table 13 is less than the current price of gasoline, the technology is economically competitive. With recent gasoline prices in the 2.00-4.00 \$/gal range, coal and natural gas are the most economical energy sources for the production of ammonia as a transportation fuel. Other energy sources have a higher cost than 4.00 \$/GGE, with wind and solar having the highest costs of all energy sources. As oil and gasoline prices increase and technological advances are made in alternative energy sources, all of the alternative energy sources could become competitive with fossil-fuels. In addition, the ammonia and hydrogen costs given in Table 13 are not dependent on oil prices.

Table 13: Comparison of alternative fuel costs in 2007 dollars

Study	Energy Source	Process	H ₂ RSP (\$/kg)	Ammonia RSP (\$/t NH ₃)	Hydrogen (\$/GJ LHV)	Ammonia (\$/GJ LHV)	Hydrogen GGE (LHV)	Ammonia GGE (LHV)
Appl	Natural Gas	Steam Methane Reforming	-	495	-	26.64	-	3.24
Gray and Tomlinson	Natural Gas	Steam Methane Reforming	2.48	560	20.69	30.12	2.52	3.67
Penner	Natural Gas	Steam Methane Reforming	3.17	689	26.39	37.07	3.21	4.51
Rutkowski	Natural Gas	Steam Methane Reforming	2.33	521	19.46	28.03	2.37	3.41
Rutkowski	Natural Gas	Steam Methane Reforming with Sequestration	2.55	561	21.24	30.21	2.58	3.68
Ganley et al.	Electricity	Solid State Ammonia Synthesis	-	347	-	18.69	-	2.27
Petri et al.	Nuclear	Electrolysis-Base Load	4.36	1,894	36.38	101.97	4.43	12.41
Petri et al.	Nuclear	Electrolysis-Off Peak	7.36	2,462	61.37	132.51	7.47	16.13
Richards et al.	Nuclear MHR	Sulfur-Iodine Thermochemical	1.84	462	15.34	24.89	1.87	3.03
Schultz	Nuclear MHR	Sulfur-Iodine Thermochemical (Low Efficiency)	2.63	613	21.92	32.98	2.67	4.01
Schultz	Nuclear MHR	Sulfur-Iodine Thermochemical (High Efficiency)	2.45	570	20.39	30.66	2.48	3.73
Giaconia et al.	Solar & NG	Sulfur-Iodine Thermochemical	7.53	1,835	62.78	98.78	7.64	12.02
Glatzmaier et al.	Solar	Photovoltaic Electrolysis (\$5/W)	23.27	5,951	193.98	320.35	23.61	38.99
Glatzmaier et al.	Solar	Photovoltaic Electrolysis (\$0.75/W)	5.78	2,262	48.22	121.74	5.87	14.82
Glatzmaier et al.	Solar	Dish Stirling Electrolysis	10.49	3,266	87.46	175.83	10.64	21.40
Glatzmaier et al.	Solar	Power Tower Electrolysis	6.46	1,637	53.82	88.12	6.55	10.72
Gray and Tomlinson	Solar	Photovoltaic Electrolysis	6.05	1,426	50.42	76.77	6.14	9.34
Kolb et al.	Solar	Power Tower Electrolysis	5.10	1,403	42.52	75.52	5.17	9.19
Kolb et al.	Solar	Sulfuric acid/hybrid Thermochemical	2.80	830	23.34	44.70	2.84	5.44
Bockris & Veziroglu	Wind	Electrolysis	3.50	1,931	29.18	103.95	3.55	12.65
Levene et al.	Wind	Electrolysis (Near Term)	5.55	2,342	46.27	126.08	5.63	15.34
Levene et al.	Wind	Electrolysis (Long Term)	2.27	1,650	18.92	88.82	2.30	10.81
Levene	Wind	Electrolysis Without Electricity Coproduction	6.77	1,727	56.45	92.94	6.87	11.31
Levene	Wind	Electrolysis With Electricity Coproduction	6.61	1,693	55.12	91.13	6.71	11.09
Reese	Wind	Electrolysis (Low Estimate)	-	660	-	35.53	-	4.32
Reese	Wind	Electrolysis (High Estimate)	-	1,320	-	71.06	-	8.65
Ryzin et al	OTEC	OTEC	-	554	-	29.84	-	3.63
Mann	Biomass	Gasification	1.99	627	16.56	33.75	2.02	4.11
Padró and Putsche	Biomass	Pyrolysis (Low Estimate)	1.47	570	12.21	30.69	1.49	3.74
Padró and Putsche	Biomass	Pyrolysis (High Estimate)	2.57	1,369	21.40	73.70	2.60	8.97
Padró and Putsche	Biomass	Gasification (Low Estimate)	1.44	488	11.98	26.29	1.46	3.20
Padró and Putsche	Biomass	Gasification (High Estimate)	2.83	1,519	23.57	81.77	2.87	9.95
Appl	Coal	Coal Gasification Without Sequestration	-	365	-	19.65	-	2.39
Gray and Tomlinson	Coal	Coal Gasification With Sequestration	1.25	322	10.46	17.33	1.27	2.11
Gray and Tomlinson	Coal	Coal Gasification Without Sequestration	1.05	281	8.77	15.12	1.07	1.84
Gray and Tomlinson	Coal	Advanced Gasification With Sequestration	0.36	147	3.04	7.91	0.37	0.96
Kreutz et al.	Coal	Coal Gasification With Sequestration	1.36	317	11.34	17.06	1.38	2.08
Kreutz et al.	Coal	Coal Gasification Without Sequestration	1.15	276	9.56	14.88	1.16	1.81
Rutkowski	Coal	Coal Gasification With Sequestration	1.83	432	15.28	23.25	1.86	2.83
Rutkowski	Coal	Coal Gasification Without Sequestration	1.50	372	12.54	20.03	1.53	2.44

- These studies were based on producing ammonia and a cost for hydrogen is not available

The comparison of energy content does not take into account the conversion efficiency gains when using hydrogen and ammonia compared to gasoline. Both fuels can be used in internal combustion engines and in fuel cells with a higher energy conversion efficiency compared to gasoline engines, which effectively makes the cost of hydrogen and ammonia cheaper since more useful mechanical energy can be extracted.

All of these studies are based on a plant production price for hydrogen and ammonia and do not include transportation to the final end user or storage in a vehicle fuel tank. Ammonia has several advantages over hydrogen that may make it a lower cost and less energy intensive vehicle fuel. One advantage is a distribution infrastructure already exists for handling ammonia in fertilizer applications, which could be used to begin a pilot program of ammonia fueled vehicles. Ammonia also has a higher energy density than liquefied hydrogen [62]. In addition, it can be stored as a liquid at ambient temperature with a moderate pressure of 17 bar [1], and it does not cause hydrogen embrittlement, which solves several storage and transportation problems associated with hydrogen.

If a carbon tax or a limitation on the amount of carbon released were to be enacted, then the hydrogen and ammonia fuels would be more favorable as a carbonless fuel. The combustion product of hydrogen is water, and for ammonia the combustion product is nitrogen and water. Since neither fuel contains carbon, then the production of carbon dioxide and other carbon containing greenhouse gases is curtailed when ammonia and hydrogen are used as fuel. Further, if the hydrogen or ammonia is produced by using a carbon-neutral process, there would be no carbon released during either the production or use of the fuel.

3.4.6 Sensitivity Analysis

A sensitivity analysis was done for the ammonia synthesis calculations to determine the effect of several key parameters and assumptions on the final selling price of ammonia. A base case was first created by assuming a hydrogen cost of 3.00 \$/kg from a hydrogen production plant and an ammonia plant rated capacity of 2,200 t/day. All other base-case economic and performance values are given in Table 9. Using these values, the base price of ammonia was found to be 775 \$/t. It should be noted that the sensitivity analysis only varied the ammonia synthesis parameters and all economic factors for producing hydrogen

are included in the assumed hydrogen cost of 3.00 \$/kg, as was done for the analysis given in Table 12.

3.4.6.1 Methodology

Seven key parameters used in the calculations were selected for the analysis, and for each, a reasonable upper and lower bound on the value was selected. The analysis was done for each parameter by varying the parameter and finding the new selling price of ammonia. The parameters, bounds, and resulting ammonia price can be found in Table 14.

Table 14: Sensitivity analysis results

Parameter	Base Case	Parameter Value	Upper Bound		Lower Bound		Decrease
			NH ₃ Price (\$/t)	Increase	NH ₃ Price (\$/t)	Decrease	
Ammonia Plant Capital	456.7 M\$	130%	809	4.46%	80%	752	2.97%
Capacity Factor	90%	80%	792	2.29%	95%	767	0.96%
H ₂ Feedstock Cost	3.00 \$/kg	4.00 \$/kg	986	27.24%	2.00 \$/kg	564	27.24%
Synloop Energy Use	390 kWh	450 kWh	791	2.09%	350 kWh	764	1.40%
IRR	15%	20%	802	3.56%	10%	749	3.31%
H ₂ to Electricity Efficiency	35%	25%	815	5.18%	45%	752	2.88%
Federal and State Income Tax	40%	45%	779	0.62%	30%	767	0.95%

Base case ammonia price: \$775/tonne with \$3.00/kg H₂

3.4.6.2 Results

The results of the analysis have been plotted in Figure 8 to show the relative impact of each parameter. The graph clearly shows that hydrogen feedstock cost has the largest affect on the price of ammonia. A key factor to decreasing the overall cost of ammonia from alternative energy sources is to improve hydrogen production technology, such as more efficient and lower cost electrolyzers, practical applications of thermochemical cracking of water, and high temperature electrolysis.

The cost of hydrogen was varied over a range of 2.00-4.00 \$/kg to account for differences in ammonia production cost depending on the hydrogen source. This range of hydrogen prices falls within the lowest and highest priced hydrogen producing technologies shown in Table 7. If the hydrogen price were to decrease to a low of 2.00 \$/kg, then the selling price of ammonia would be 564 \$/t.

The efficiency of converting hydrogen to electricity had a somewhat large impact on overall cost. A plant that produces electricity and converts it to hydrogen through an electrolyzer, such as a solar photovoltaic or wind plant, could divert some of the electrical energy to

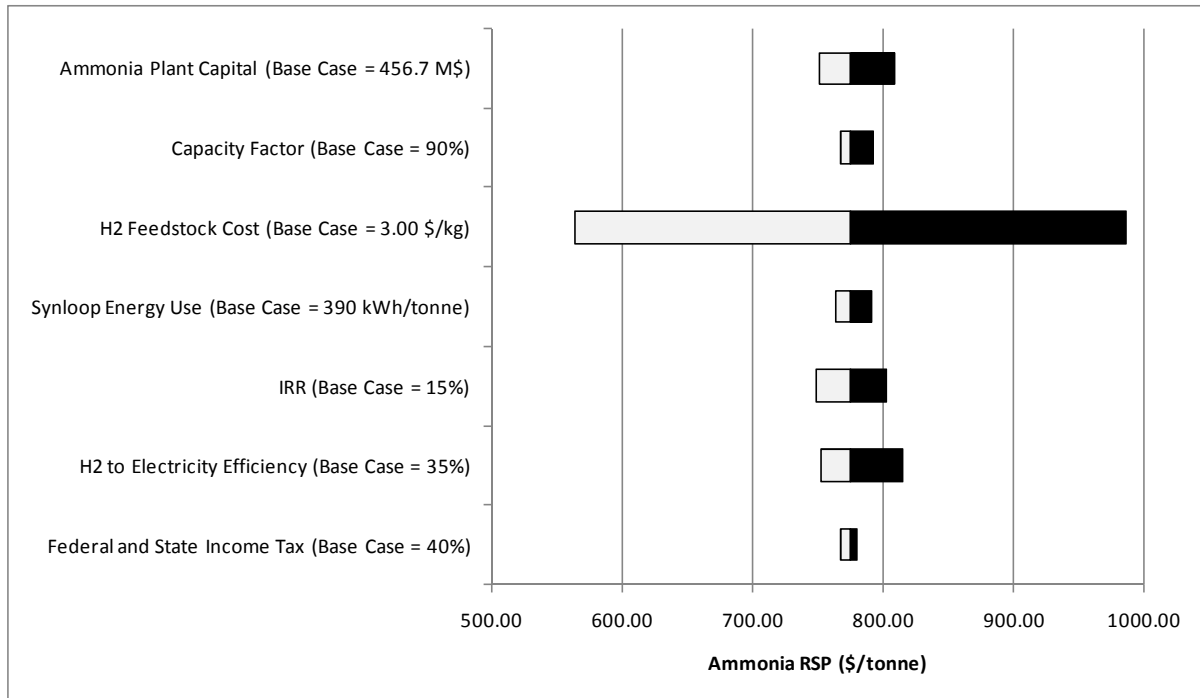

Figure 8: Sensitivity analysis of ammonia selling price

directly power the conversion process, thus reducing energy losses. Such a plant could decrease the selling price to 702 \$/t due to the lower plant capital cost, lower operating and maintenance cost, and higher efficiency of the plant design without a gas turbine.

The plant capital and internal rate of return also have a large effect on the selling price of ammonia. The 80-130% range for the plant capital cost shows how an increase or decrease in plant construction cost would affect the facility. If the capital cost of the ammonia production facility, which does not include the capital cost of the hydrogen production facility, was doubled then the ammonia selling price would be 890 \$/t. A higher or lower IRR may be desired by investors, and its effects are shown in Figure 8.

The remaining parameters, which include capacity factor, tax rate, and synloop energy use, all had a small impact on the selling price. The changes in capacity factor account for problems that may be encountered with the new technology. The tax rate was adjusted to see how a potential change in taxes, either through economic incentives offered for alternative energy ammonia production or from a change in the corporate tax rate due to political changes, may affect the economics of the plant. The synloop energy use had a minor affect on overall ammonia price.

3.5 Summary

A low-cost source of ammonia is needed in the Ammonia Economy, and this analysis showed that the ammonia sources with the lowest costs are coal and natural gas, and possibly OTEC. Coal provided the lowest cost of ammonia with estimated costs between 147 \$/t and 432 \$/t including carbon sequestration, which is significantly less than the recent fertilizer market price of over 700 \$/t. Converting this cost to a gallon of gas equivalent (GGE), which is the equivalent amount of energy contained in a gallon of gasoline, would provide a transportation fuel cost of 0.96-2.83 \$/GGE. This cost is competitive with recent the recent cost of gasoline between 2.00 \$/gal and 4.00 \$/gal. Natural gas sources can produce ammonia for a cost of 495-689 \$/t, or 3.24-4.51 \$/GGE, which is economical in terms of ammonia as a fertilizer, but priced higher than the recent cost of gasoline transportation fuel. OTEC appears to be the only alternative energy source that can compete economically with fossil fuels; however its economic analysis is not based on an actual operating system, but rather on a proposed system. For example, OTEC could provide ammonia delivered to a port in Florida for 554 \$/t, or 3.63 \$/GGE.

Although coal, natural gas, and OTEC all provided an economical source of ammonia for use as a fertilizer, only coal provided a cost of transportation fuel lower than the recent prices for gasoline. Other ammonia sources from alternative energy provided costs that were generally above the current cost of ammonia and gasoline. However, as described in this chapter, technological advances could make these renewable resources more competitive with fossil fuels.

CHAPTER 4. LARGE-SCALE STORAGE OF ALTERNATIVE FUELS

Production is the most obvious part of the overall infrastructure for a fuel; however the energy and cost requirements associated with storage and distribution are equally important. For example, large-scale fuel storage facilities are required to maintain a steady fuel supply and to account for seasonal variances in fuel production and consumption. In the case of storage for hydrogen and ammonia, this storage requires not only a capital cost for the facility, but also an operating energy cost depending on if pressurized or low-temperature storage is used. The energy use and efficiency of low-temperature storage is analyzed herein for both hydrogen and ammonia transportation fuels.

4.1 Pressure Storage

Pressure storage is performed at ambient temperatures and high pressures. The storage system consists of a cylindrical or spherical pressure vessel along with valves and controls. The system does not lose any of the stored fuel, and it requires no energy to maintain the pressurized state of the fuel in the tank. The pressure required for storage is a limiting factor since the mechanics of the material used for vessel construction practically limit the pressure vessel size. However, larger storage volumes can be achieved by using multiple storage vessels.

4.1.1 Ammonia Pressure Storage

Ammonia can be stored as a liquid at an ambient temperature of 20°C if a pressure of 8.58 bar is maintained, and the energy density of ammonia at such a state is 13.77 MJ/L. However, ammonia pressure storage vessels commonly operate at a pressure of 17 bar to keep the ammonia as a liquid even if ambient temperature increases [1]. This pressure requirement is modest and carbon steel can be used for the construction of the tank.

The size of the ammonia pressure vessel is practically limited to about 270 t and a general thumb-rule is that approximately 2.8 t of ammonia can be stored per tonne of steel [1]. This quantity of storage is suitable for fueling stations. However, larger storage vessels would be needed to store the output of a large ammonia production facility, which can produce thousands of tonnes of ammonia per day.

4.1.2 Hydrogen Pressure Storage

Hydrogen is a gas at 20°C with a low energy density. High pressures must be used to compress the gas and to achieve a higher energy density for storage. Hydrogen high-pressure storage vessels operate at a maximum of 300 bar [63], which corresponds to an energy density of 2.96 MJ/L. Hydrogen would therefore require not only a volume 4.65 times greater than that of ammonia for the same amount of energy stored, but it would also require a much higher pressure requiring stronger and heavier tank construction, along with an added expense to compress the gas. This difference in energy density is especially important if these fuels are to be considered as a vehicle fuel where on-board storage space is limited.

4.2 Low-Temperature Storage

For large-scale storage of ammonia or hydrogen, low-temperature storage is typically used based on cost considerations. For example, both ammonia and hydrogen can be stored as a liquid at atmospheric pressure if a low enough temperature is maintained. The low-temperature storage system consists of a large insulated tank and a refrigeration system to maintain the fuel as a liquid at the low temperature. The insulated vessel is only designed with the structural strength to withstand the static pressure of the fluid, which greatly reduces the steel content of the vessel compared to pressure storage.

It should be noted that the low-temperature storage system has the disadvantage of requiring energy for storage in that a refrigeration system is used to cool and liquefy the inbound fuel and to keep the fuel as a liquid. The fluid continuously boils off in the tank, and this vapor must then be liquefied or else fuel would be lost from the vessel.

4.2.1 Ammonia Low-Temperature Storage

Ammonia can be stored as a liquid at atmospheric pressure if a fluid temperature of -33°C is maintained. A two-stage refrigeration system, which uses the stored ammonia directly as the refrigerant in the refrigeration cycle, is used to keep the ammonia at the low temperature and to cool it upon entry to the storage facility (Figure 9). The energy density of the cooled ammonia is 15.37 MJ/L, which is slightly denser than ammonia contained in pressurized storage at 13.77 MJ/L.

Ammonia storage vessels are constructed in a range of sizes from 4,500 t to 45,000 t, although typical facilities store between 15,000 t and 60,000 t [1, 64]. The low temperature system can store 41- 45 t of ammonia per tonne of steel, which is nearly 15 times more efficient in than pressure storage [1]. This lower steel usage compared to pressurized storage, and the resulting lower capital cost, is one of the main factors why low-temperature storage is widely in use for large-scale ammonia storage.

4.2.2 Hydrogen Low-Temperature Storage

Hydrogen at a temperature of -253°C can be stored as a liquid at atmospheric pressure with an energy density of 9.98 MJ/L. This very low temperature requires a much more complex cooling system design than that required for gases that are liquid at warmer temperatures. Specifically, liquefaction of hydrogen requires the use of liquid nitrogen to pre-cool compressed hydrogen gas to -195°C , followed by hydrogen expansion to atmospheric pressure to liquefy and reach the -253°C liquid hydrogen temperature [63]. This two step process is required since hydrogen must be below the inversion temperature of -71°C for it to cool upon expansion [63]. For this reason, a more complex and costly cooling system that uses several compressors, pumps, heat exchangers, and a liquid nitrogen system is required for the liquefaction of hydrogen.

Hydrogen storage vessels are constructed in smaller sizes than ammonia storage vessels. Liquid hydrogen tanks can be constructed up to a capacity of 900 t, although the largest liquid hydrogen tank in use has a capacity of only 228 t [63]. All of these tanks must be heavily insulated to minimize heat gain from the environment.

4.3 Low-Temperature Storage Analysis

An analysis was completed for both a low-temperature ammonia and hydrogen storage system. This analysis directly compares the amount of energy required for each, which is necessary in order to assess the use of both chemicals as a transportation fuel. The following analysis uses several assumptions that are necessary to allow for a fair comparison between the two low-temperature storage systems.

4.3.1 Key Parameters and Assumptions

The comparative analysis assumes that both the hydrogen and ammonia storage systems are sized to hold the same quantity of hydrogen. Conversely, if the same volume or the same mass was used for the two systems it would not be a fair assessment since there would be a significant difference in the amount of energy stored in each tank. The ammonia storage capacity selected was 15,000 t, which is the smallest sized commercial facility commonly used by industry [64]. The hydrogen storage vessel capacity is therefore 2,664 t, which is the same amount of hydrogen in the ammonia storage vessel. This vessel is larger than the 900 t capacity that has been reported by Amos [63], although for this paper it is assumed several tanks would be used together to store such a large quantity of hydrogen.

Boil-off in refrigerated storage is caused by heat gain from the environment and is defined as the percentage of stored liquid that vaporizes each day. Large scale ammonia and hydrogen tanks typically have a boil-off rate below 0.1%/day [63, 65]. For this analysis, a boil-off rate of 0.1%/day is used for both the hydrogen and ammonia facilities since it is a conservative estimate, and it allows both facilities to have the same amount of loss. A lower boil-off can be achieved by using better insulation, although capital cost for the facility will increase. It should be noted that due to the much colder temperature of stored hydrogen compared to ammonia, more insulation would be required to minimize boil-off in a hydrogen tank than in an ammonia tank.

Both storage systems receive hydrogen from the same source, which is assumed to already be pressurized to 104 bar at an ambient temperature of 20°C. The method used for hydrogen production and its associated efficiency is therefore eliminated in this analysis, which allows one to directly compare only the storage energy.

The length of storage is assumed to be 182 days, which is based on representing a storage period between summer and winter seasons. An example of the need for this type of storage would be the hypothetical case of using wind from an area with strong winter winds to produce hydrogen or ammonia as a vehicle fuel. Such a system would produce large quantities of fuel in the winter, and less during the summer peak driving season. The storage

vessel would be able to store the fuel between seasons to allow for a reliable supply of fuel for vehicles.

The ammonia storage system uses the hydrogen source, along with nitrogen separated from air, as the input to an ammonia synthesis process. The energy requirement for ammonia synthesis is 0.390 kWh/kg-NH₃ as reported by Gosnell [59]. The ammonia exits the synthesis loop at a pressure of 100 bar and a temperature of -25°C [1]. It then enters the storage vessel, where it expands to atmospheric pressure and is cooled by using a two stage ammonia refrigeration loop. After the tank is filled, the boil-off vapors are continuously cooled by the refrigeration system.

The ammonia refrigeration system used to determine the energy requirements in this study was modeled after an approach shown in Figure 9 [64]. The boil-off ammonia vapor is first compressed to an intermediate pressure of 4.12 bar before flowing into a flash tank for cooling. A second-stage compressor further compresses the gas to a pressure that allows for the ammonia to condense in the air-cooled condenser. The condenser pressure modeled for this analysis is 13.5 bar, which is at a temperature of 35°C. The condenser fan has also been

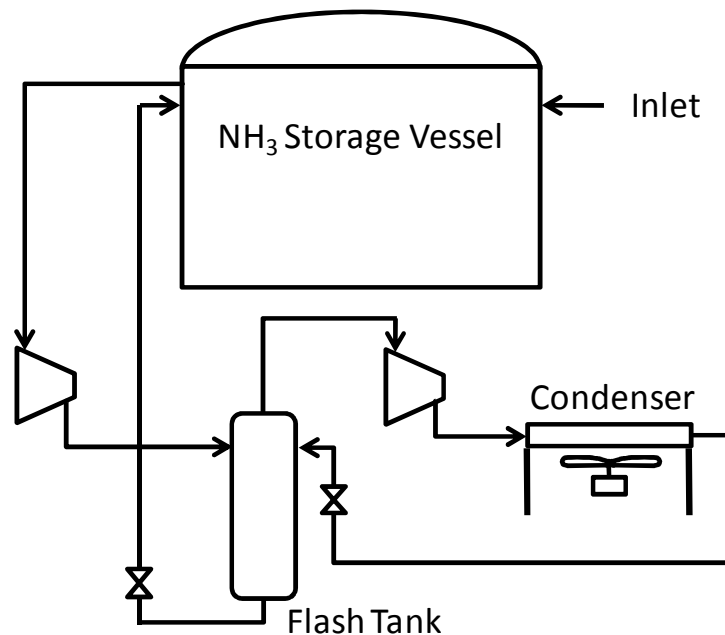

Figure 9: Diagram of ammonia storage vessel and refrigeration system [64]

modeled in this analysis and a pressure drop across the fan of 0.005 bar is used to calculate power requirements. The condensed ammonia enters the flash tank, expands, and is separated into liquid and vapor. The vapor passes through the second stage again, and the liquid at the bottom of the flash tank is sent back to the storage vessel where it expands to tank pressure. The hydrogen storage system requires liquefaction of the hydrogen before storage in the large low-temperature vessel. The actual amount of energy required for liquefaction was found to be between 8.0 and 12.7 kWh/kg-H₂, compared to the ideal energy of liquefaction of 3.228 kWh/kg-H₂ [63]. Additional information from Praxair, which is a company that operates hydrogen liquefaction facilities, showed an energy use of 12.5-15 kWh/kg-H₂ for operating plants [66]. Based on the above considerations, a value of 10 kWh/kg-H₂ was assumed for this analysis. This value may be lower than some estimates, but it is assumed that any large-scale use of hydrogen liquefaction would justify the implementation of efficiency improvements. The liquid hydrogen then enters the storage vessel where a continuous boil-off occurs. The boil-off vapors are then liquefied by using the same hydrogen liquefaction system for inbound hydrogen fuel, which uses 10 kWh/kg-H₂.

4.3.2 Analysis Results

The results of the analysis are summarized Table 15 where it can be observed that the ammonia storage system uses less energy and is more efficient than the hydrogen storage system. Specifically, the total energy input is 42,552 kJ/kg-H₂ and 8,839 kJ/kg-H₂ for the hydrogen and ammonia storage systems, respectively, which one can assume is obtained from an external electrical energy source. Efficiency is defined for both systems as the chemical energy stored in the vessel divided by the sum of both the energy input to the system and the chemical energy stored in the vessel. The efficiency calculated for ammonia is 93.6% and for the hydrogen system it is 76.9%.

Table 15: Comparison between hydrogen and ammonia low-temperature storage

	H ₂ Refrig. Storage	NH ₃ Refrig. Storage
Total Energy Input (kJ/kg H ₂)	42,552	8,673*
Total Mass (kg H ₂)	2,664,000	2,664,000*
Work Input (GJ)	113,358	23,104
Energy Out HHV (GJ)	377,702	338,145
Storage Temperature (°C)	-253	-33
Efficiency HHV	76.9%	93.6%
Energy Density (MJ/L)	9.98	15.37

*Ammonia values normalized to hydrogen

The diagram in Figure 10 shows a graphical representation of where the energy is used, along with a general process flow diagram for the ammonia and hydrogen system. The diagram demonstrates the overall results that the ammonia system uses significantly less energy for fuel storage, including the fact that each process for the ammonia system uses much less energy than the corresponding process for the hydrogen system.

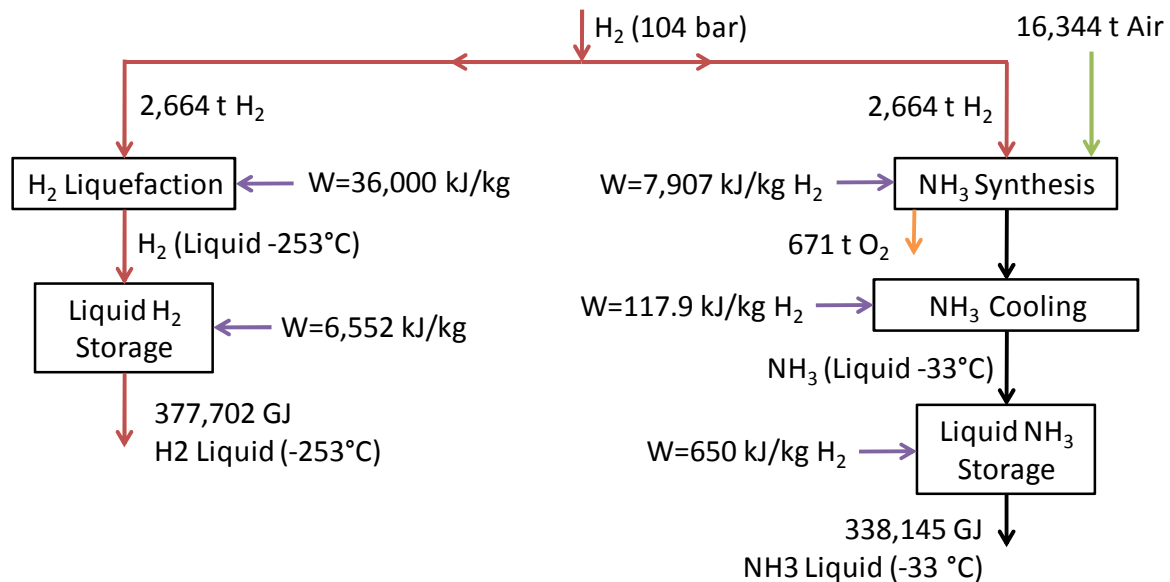
**Figure 10: Hydrogen and ammonia low-temperature storage system diagram**

It should be noted that all of the energy use values reported in Table 15, Figure 10, and in this discussion are reported per kilogram of hydrogen, and therefore, the ammonia numbers have all been adjusted higher by a factor of 5.63 to adjust for the higher mass of ammonia per stored quantity of hydrogen. The energy use for each process can therefore be compared

with the respective process for the other fuel, which is important considering that without this adjustment a direct comparison between the processes could not be made.

The cooling process for the ammonia system uses only 117.9 kJ/kg-H₂, while the hydrogen system uses 36,000 kJ/kg-H₂. As noted before, hydrogen requires a very energy intensive refrigeration process to achieve a temperature of -253°C, while in comparison, the ammonia liquid temperature is relatively warm at -33°C. The ammonia also enters the liquefaction process from the ammonia synthesis process as a liquid at -25°C, and therefore the amount of heat removal required to achieve the -33°C storage temperature is minimal compared to the 273°C decrease in temperature and phase change for hydrogen liquefaction.

The energy required for 182 days of storage is an order of magnitude higher for the hydrogen storage compared to the ammonia storage system due to the less energy-intensive ammonia refrigeration process. It should be noted that once the fuel is in liquid form and in the storage vessel the only energy required for storage is refrigeration energy to maintain the fuel as a liquid. Therefore, doubling the storage time would only double the amount of energy used in the storage segment of the process.

At the end of 182 days, the entire initial quantity of both fuels will remain in the storage vessel since all energy that is used to operate the facility is assumed to come from an external electricity supply. It should be noted that more energy will be stored in the hydrogen due to the slightly larger higher heating value of the fuel compared to the higher heating value of ammonia, although the same total amount of hydrogen is stored in both systems. The resulting fuel is then found to have an energy density of 9.98 MJ/L and 15.37 MJ/L for hydrogen and ammonia, respectively.

When examining Figure 10, it can be seen that only a small amount of energy is required for the actual storage while over 90% of the total energy required for the ammonia storage system is used to produce the ammonia from the hydrogen. If the model is changed from producing ammonia from hydrogen supply as shown in Figure 10 to storing ammonia from an ammonia source at 20°C and 17 bar, then the overall efficiency of the ammonia storage system would increase to 99.0%. Such a change would increase the energy required to cool

the ammonia to 639.8 kJ/kg-H₂. However, the energy required to maintain the ammonia as a liquid in the tank would not change. The total energy input would decrease to 1,289 kJ/kg-H₂ for ammonia storage compared to 42,552 kJ/kg-H₂ for hydrogen storage.

4.3.3 Low-Temperature Storage System Costs

A budget estimating quote from CB&I provided costs for building both a low-temperature ammonia storage facility and a hydrogen storage sphere in 2006 dollars, which were adjusted to 2007 dollars by using the Chemical Engineering Plant Cost Index [2]. The low-temperature ammonia facility, including a 25,000 t storage vessel, refrigeration system, and all ammonia handling and plant facilities, was estimated to cost 20.2 M\$ adjusted to 2007 dollars [67]. The hydrogen sphere would contain 506 t of at a cost of 9.7 M\$ adjusted to 2007 dollars, which does not include the cost of the plant facilities or the refrigeration system [67]. The ammonia system would be capable of holding 564 TJ while the hydrogen system would only be able to store 72 TJ.

A suitable hydrogen liquefaction system would need a capacity of about 1,500 kg/h to match the fill rate for the ammonia tank. Such a system would cost 38.8 M\$ in 1995 dollars [63]. Adjusting the cost to 2007 dollars by using the Chemical Engineering Plant Cost Index gives a cost of 53.5 M\$ [2]. Combining this cost with the storage vessel cost, an approximate total facility cost of 63.2 M\$ is estimated for the hydrogen storage system compared to the 20.2 M\$ for the ammonia storage system.

The total specific capital cost for the ammonia and hydrogen systems is 878 \$/GJ and 36 \$/GJ of stored chemical energy, respectively. This shows that the large-scale ammonia storage facility capital cost is nearly 25 times less than that of hydrogen per unit of stored energy. From this cost estimate, a specific storage cost can be determined based on the length of storage and the same economic parameters that were used for the ammonia synthesis plant analysis (Table 9). The result for 182 days of storage is a cost of 98.74 \$/GJ and 4.03 \$/GJ of storage for hydrogen and ammonia, respectively. This is equivalent to a cost of 14.00 \$/kg-H₂ for hydrogen storage and 0.51 \$/kg-H₂ for ammonia storage.

In addition to the capital cost, there is also an energy cost associated with the operation of a low-temperature storage facility. The energy cost would vary depending on the amount of fuel stored in the vessel at any given time and how often the tank is filled and emptied. For the 182 day storage period, it can be seen from Table 15 that it takes about five times more energy to store hydrogen than ammonia. If electricity costs 0.08 \$/kWh and 182 days of storage is used, then the cost of hydrogen and ammonia storage is therefore 0.95 \$/kg-H₂ and 0.03 \$/kg-H₂, respectively, ignoring the capital cost. Combining the energy cost with the capital cost gives the total storage cost for 182 days of storage to be 14.95 \$/kg-H₂ for hydrogen, and 0.54 \$/kg-H₂ for ammonia. Therefore, ammonia has a cost of storage nearly thirty times less than that of hydrogen.

It should be noted that the cost of storage is highly dependent on the length of storage. If the tank is filled and emptied more times per year, then the capital contribution to the overall storage cost would decrease. For example, if the storage time is decreased to 15 days, then the cost for hydrogen and ammonia storage is 1.97 \$/kg-H₂ and 0.06 \$/kg-H₂, respectively. The cost difference between the two fuels is still about a factor of thirty just as in the 182 days of storage analysis. However, the cost for storage decreases significantly.

4.4 Summary

The analysis found that the ammonia low-temperature storage system uses significantly less energy, operates more efficiently, and has a lower cost than the hydrogen storage system. Specifically, the efficiency of the ammonia storage system is 93.6% whereas the hydrogen system has an efficiency of 76.9%. The ammonia system also uses nearly five times less energy to store a given quantity of hydrogen than the hydrogen storage system. The capital and operating cost of the ammonia facility was also found to be cheaper than for the hydrogen system with a cost of 20.2 M\$ and 63.2 M\$, respectively. Based on 182 days of storage, these costs result in a storage cost of 14.95 and 0.54 \$/kg-H₂ for hydrogen and ammonia, respectively. In addition to the lower operating and capital cost requirement for ammonia storage, a significant infrastructure and industry experience exists for low-temperature storage of ammonia as it relates to the fertilizer industry. In contrast, there are few large-scale hydrogen storage facilities in use today. Based on a wide range of

parameters assessed in this chapter, ammonia would be preferred over hydrogen for any fuel storage system.

CHAPTER 5. TRANSPORTATION OF ALTERNATIVE FUELS

An alternative fuel must be transportable in order to allow for distribution from production facilities to end users. Ammonia and hydrogen can both be transported by road, rail, or waterway, all of which are fundamentally the same type of transport since each carries a fixed quantity of fuel in a storage vessel. Both fuels can also be transported via pipeline, which would provide a continuous flow of fuel to end users. The following analysis compares the storage vessel and pipeline transport methods, along with an analysis of the overall energy use and efficiency for high-volume long-distance fuel transport. An analysis of a natural gas pipeline system has also been included to provide a comparison with ammonia and hydrogen, especially since natural gas use as a fuel has been promoted by a number of entities, including the Pickens Plan [68].

5.1 Fuel Transportation with Storage Vessels

Storage vessels are commonly used for transport of fuels. A few examples would be a tractor-trailer carrying gasoline to a fueling station, a rail car transporting ethanol, or a supertanker transporting oil. All of these storage vessels carry a fixed quantity of fuel between locations. These transport methods are able to use existing transportation infrastructure, such as highways, railroads, waterways, and oceans to move fuel.

The storage vessel can either use pressurized or low-temperature storage depending on the fuel and the size of the storage vessel. As was described previously, the pressurized storage tanks use no energy to maintain the fuel in the tank, but it requires high pressures and heavy tank designs. Conversely, low-temperature storage uses relatively lightweight tanks at low-temperature, but boil-off occurs and the fuel must be cooled, which requires significant amounts of energy. Since land-based transportation methods, such as road and rail, are typically weight limited, the tank weight is an important factor, especially when one considers that an increase in tank weight decreases the quantity of fuel that can be transported per vehicle.

5.1.1 Ammonia Fuel Transportation with Storage Vessels

Ammonia is easily transported by truck and rail as a pressurized liquid. Highway trailers are currently in use with 43,530 L of capacity and an operating pressure of 20.7 bar [69]. Such a tank could hold 26.6 t of ammonia, or 600 GJ of energy on a HHV basis, and be transported by one over-the-road truck. Rail transport uses a similar pressurized tank with 126,810 L of capacity at 15.5 bar, which would be capable of transporting 77.5 t of ammonia or an equivalent energy of 1,746 GJ [69].

Ship or barge transport of ammonia could be done by using either pressurized or low-temperature storage vessels. Low-temperature storage uses less steel than pressurized storage, resulting in more ammonia transporting capacity and a lower initial cost design. Existing oceangoing ships are capable of transporting 50,000 t of ammonia by using low-temperature storage [1].

5.1.2 Hydrogen Fuel Transportation with Storage Vessels

Hydrogen as a gas is difficult to store and transport due to its low energy density.

Pressurized hydrogen tube trailers pulled behind a highway tractor can be used to transport about 340 kg at 179.1 bar [70]. This quantity of hydrogen has an energy content of 48 GJ, which is twelve times less energy than transported by using a highway ammonia tanker.

Transporting hydrogen as a liquid would allow more hydrogen to be carried by the vehicle due to the decreased tare weight of the trailer. Specifically, a liquid hydrogen trailer could carry about 3,900 kg of hydrogen, which is an order of magnitude more than a compressed hydrogen tube trailer can hold [70]. This method of transportation would require first liquefying the hydrogen, which is an energy intensive process that uses the energy equivalent of nearly one-quarter of the total energy contained in the hydrogen. The insulated liquid tank would not use a refrigeration system due to the short-duration transportation time and also to decrease the weight of the trailer, and therefore a small amount of boil-off loss would occur during transportation. Liquid hydrogen transport would allow for the transport of 553 GJ of energy per over-the-road truck, which is similar in energy carrying capacity to an ammonia tanker. However, liquid hydrogen transportation requires more energy for the overall process than ammonia transportation when the fuel liquefaction energy is included in the comparison.

5.1.3 Summary of Storage Vessel Transport

Table 16 summarizes the methods of ammonia and hydrogen transport described in this section. Comparing the truck transport of the two fuels shows how the high-energy density of ammonia makes ammonia much easier and cheaper to transport than hydrogen. A truck can transport 600 GJ of energy when hauling ammonia while only 48 GJ can be transported with compressed hydrogen. Assuming the per-truck transportation cost is the same regardless of the type of fuel, then twelve times the number of trucks and expense would be required to transport hydrogen compared to ammonia. Liquefying hydrogen improves the ratio so a similar cost would be expected for transporting both fuels, but a major energy cost is incurred with liquefying hydrogen due to the energy intensive liquefaction process, as noted previously.

Table 16: Comparison of storage vessel transport methods for ammonia and hydrogen

Fuel Shipping Method	Ammonia			Hydrogen	
	Ship	Rail	Truck	Truck	Truck
Type of Storage	Low-Temp	Pressurized	Pressurized	Pressurized	Low-Temp
Gauge Pressure (bar)	-	15.5	20.7	179.1	-
Capacity (kg)	55,000,000	77,500	26,600	340	3,900
Energy Capacity (GJ-HHV)	1,240,000	1,746	600	48	553

5.2 Pipeline Fuel Transportation

Pipelines are used to move high volumes of fluids long distances, since pipelines have lower transportation costs compared to storage-vessel transport [71]. Pipelines consist of a pipe and several compressor or pump stations for gasses and liquids, respectively. The compressor and pump stations will collectively be called booster stations in this analysis since they are used to increase, or boost the pressure in the pipeline. Specifically, booster stations are required to supply the pressure needed to overcome frictional losses and to provide the motive force to move the fluid through the pipeline.

Pipelines are currently used on a large scale for transporting water, hydrocarbons, ammonia, and air products. It should be noted that it typically takes many years to receive permits and to construct a new pipeline, and as a result a significant capital cost is incurred. However, once a pipeline is constructed, a low-cost transportation method is available for fluid transport. This transportation mode is also reliable since there are no moving parts, except at

the booster stations, and pipelines are often installed underground where they are not affected by weather conditions.

5.2.1 Ammonia Pipeline Transport

Long distance transport of ammonia is typically done by using pipelines since it is the most economical transport method [1]. A 4,830 km carbon steel pipeline network is already used in the United States to transport ammonia from port and production facilities to agricultural areas for use as a fertilizer (Figure 11). There are currently storage facilities and terminals located along the pipeline to support operations, as an example, there are more than 800 retail ammonia retail locations in Iowa alone [72].



Figure 11: Ammonia pipelines in the United States [72]

5.2.2 Hydrogen Pipeline Transport

Hydrogen pipelines are in limited use in parts of the United States, Canada, and Europe where industrial use of hydrogen requires major quantities of hydrogen to be transported [63]. The United States has 719 km [63] of hydrogen pipelines, which is much smaller than the 4,830 km ammonia pipeline and miniscule compared to the 289,680 km of the natural gas pipeline [73].

Hydrogen embrittlement is potentially an issue with hydrogen pipelines. The problem can be overcome if steel with yield strength below 689 MPa is used instead of high strength steels [73]. There are additional material issues, such as corrosion, fatigue, and cracking, that will require more testing before large-scale high-pressure hydrogen pipelines are widely used [73].

5.3 Pipeline Analysis

Ammonia, hydrogen, and natural gas pipeline transportation energy use and efficiency are determined in the following analysis. For each system a scenario is used where fuel is to be transported over a distance of 1,610 km and delivered at a pressure acceptable for vehicle fueling. This distance was selected since it represents several potential scenarios where fuel would need to be transported from an area with a major energy resource to a populated area that has a high demand for transportation fuel. For example, Chicago, Illinois is located approximately 1,610 km from Wyoming coal mines and Texas natural gas resources. A transportation system would be needed to link these energy sources with the end use, and pipelines are the ideal choice based on operating cost and the ability to move large quantities of fuel.

There are many different pipeline design parameters that can be considered, and the various combinations of parameters produce a wide range of results. The description that follows includes the major assumptions and methodologies used in the analysis.

5.3.1 Key Parameters and Assumptions

The main calculations for analyzing pipeline operations involve piping losses and booster station operations. All variables are interrelated and changing one variable could affect the output in other areas depending on how the analysis is constrained. For example, choosing a longer distance between booster stations could either increase the energy consumption while maintaining the same flow rate, or else it could maintain the same energy consumption as the flow decreases. Several of these critical variables are presented and explained herein. When differences were required between the fluid models due to differences in liquid and gas flow

properties, each system was modeled with the intent of maximizing the efficiency and reducing the energy use of each system.

Pipeline specifications were first selected, including a maximum pipeline pressure of 104 bar in a 12 inch nominal diameter pipeline. This pressure corresponds to the maximum pressure that is currently in use in natural gas pipelines [74]. The pipe thickness needs to be selected to determine the inside dimensions of the pipe, which was calculated by using the modified Barlow equation [75]. A seam joint factor and standard deration factor of unity was used since the pipeline is assumed to be a seamless-weld pipe operating at less than 121°C. The pipeline is also assumed to be a Class III pipeline with a design factor of 0.50, which corresponds to a pipeline located in populated areas but not areas with buildings more than four stories above the ground. A pipe material grade API 5L X56 steel was selected resulting in a minimum pipe wall thickness of 0.342 inches (8.69 mm). Based on these criteria, a nominal pipe of 12 SCH 40s was selected. The outside diameter of the pipeline is 12.75 inches (323.85 mm) with a wall thickness of 0.375 inches (9.53 mm), resulting in an inside diameter of 12.00 inches (304.8 mm) and a maximum operating pressure of 114 bar.

It should be noted that the steel grade could be increased or decreased, resulting in a change in wall thickness requirements. A higher-grade steel would cost more per tonne, but less steel is required to construct the pipeline and a larger inside diameter is available for fluid flow. Conversely, a lower steel grade would cost less per tonne, but more steel is required for pipeline construction and the inside diameter of the pipeline is decreased, thus limiting flow. The selection of steel grade becomes an economic consideration that should be calculated based on current steel prices in order to determine the lowest cost and best design. For this analysis, each system uses the same operating pressure and steel grade, and therefore the cost of the pipe for each system is the same.

Pipeline velocities are limited based on the erosional velocity, which is the velocity at which erosion of the interior of the pipeline occurs over time [75]. This maximum velocity is calculated based on the gas density in the pipeline (Equation 6). Since the lowest density occurs immediately before a booster station where the fluid pressure is at the minimum, the lowest erosional velocity will be at the inlet to the booster station. Pipelines are typically

operated at 50% of the erosional velocity [75], and therefore the mass flow rate in the pipeline is based on 50% of the erosional velocity at the inlet to the booster station.

$$V_{erosional} \text{ [ft/s]} = \frac{100}{\sqrt{\rho \text{ [lb/ft}^3\text{]}}} \text{ Erosional Velocity} \quad \text{(Equation 6) [75]}$$

The distance between the compressor or pump stations is another critical parameter that determines the flow rate. Each pipeline system uses the same distance of 128.8 km between booster stations. For a fair analysis, the same distance was used for each system since using more booster stations for one of the pipelines would increase the capital cost for that system over the other. The distance between the last station and the end of the pipeline is 64.4 km.

The pipeline is assumed to be isothermal, with the fluid at the ground temperature of 12.8°C, and to be horizontal with no elevation changes over the length of the pipeline. The heat added to the fluid in the booster stations is assumed to be removed before the fuel enters the pipeline. These assumptions simplify the model by making the fluid temperature constant. Otherwise, a change in temperature in the pipeline would change the density and friction factor of the fluid.

The pressure in the pipeline over a pipe segment is based on the friction loss in the pipeline, with the friction factor being calculated by using the Colebrook-White equation with a pipe roughness of 0.045 mm [75]. The difference in pressure can be calculated based on the friction factor and Reynolds number evaluated at the average pipe segment velocity. The average velocity is based on the average pipe pressure calculated by using Equation 7, where P_1 is the entrance pressure and P_2 is the exit pressure from the pipe segment.

$$P_{avg} = \frac{2}{3} \left(P_1 + P_2 - \frac{P_1 P_2}{P_1 + P_2} \right) \text{ Average Pipeline Pressure} \quad \text{(Equation 7) [75]}$$

The booster stations increase the pressure in the pipeline back to the maximum pressure of 104 bar, and each station is assumed to have an inlet and exit loss of 0.7 bar to account for valves and pipe fittings that limit flow. Further, each pipeline pump and compressor is assumed to have an isentropic efficiency of 90% and 70%, respectively. The high pressure

compressor, which is used to compress the hydrogen to 690 bar at the end of the pipeline, has an assumed efficiency of 55% [66].

A diagram of the ammonia pipeline system can be seen in Figure 12. For this system, hydrogen is obtained from a source at 104 bar. It is first converted to ammonia by using the Haber-Bosch process with nitrogen separated from air. The conversion efficiency is 0.390 kWh/kg-NH₃, as was previously reported. The ammonia exits the synthesis loop and is pumped to pipeline pressure of 104 bar before entering an 128.8 kilometer section of pipeline. Upon exit, it is pumped back to the pipeline pressure of 104 bar and sent back into the pipeline. This pipeline segment is repeated twelve times to cover a total distance of 1,545 km. After the final pump station, the ammonia flows 64.4 km and exits as a liquid at high enough pressure to be used as a vehicle fuel. The pumping energy and ammonia synthesis energy are reported in the total amount of energy required to move the ammonia.

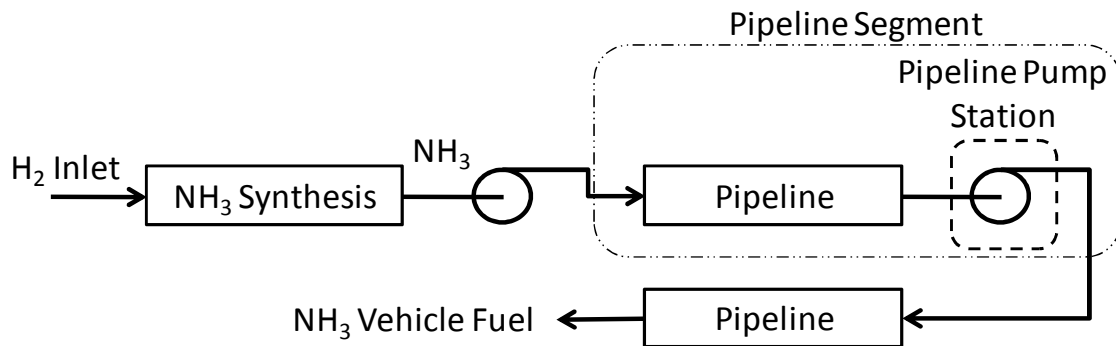

Figure 12: Diagram of the ammonia pipeline system

The hydrogen pipeline system, as shown in Figure 13, is more complex than the ammonia system since the fluid is a gas, which requires compressors. The hydrogen is obtained from a source at 104 bar and enters an 128.8 km pipeline segment. Upon exiting, it enters a compressor station that uses a two-stage compressor with intercooling and aftercooling. A two-stage compressor was selected since the compression energy is less than a single-stage design. The intercooler has an assumed pressure drop of 0.7 bar, and it is assumed to cool the hydrogen to 35°C before entering the second stage of compression. The heat of compression from the last stage is removed in the aftercooler before the hydrogen enters the pipeline. This segment is repeated twelve times and is followed by a 64.4 km segment, as in

the ammonia pipeline system. The hydrogen exiting the pipeline is then compressed to 690 bar for use as a vehicle fuel by using a two-stage compressor with intercooler.

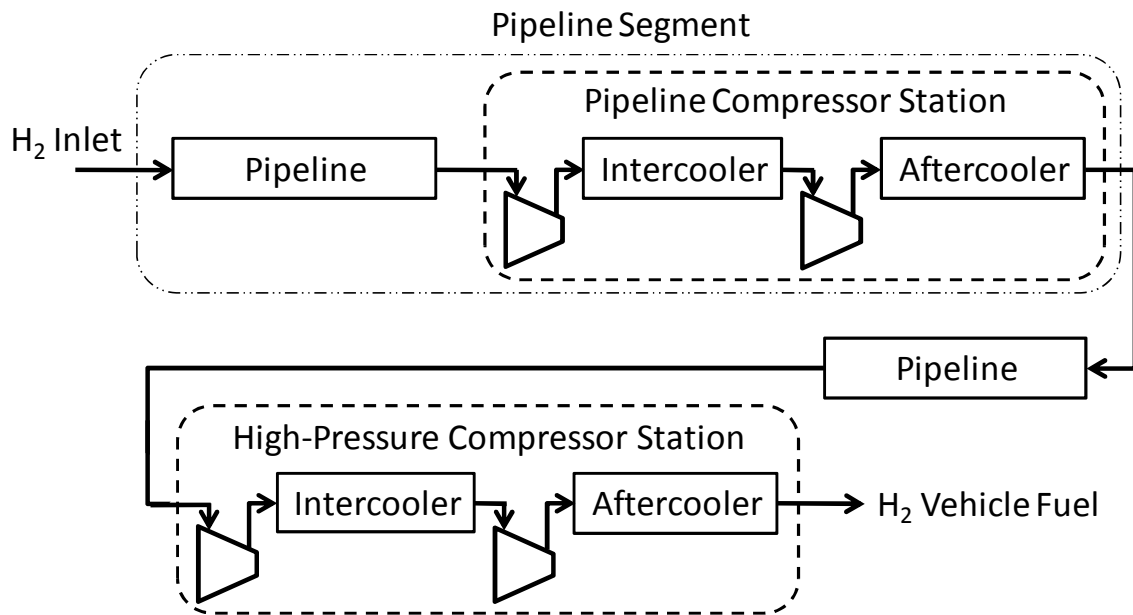

Figure 13: Diagram of hydrogen pipeline system

The natural gas fuel analysis was done by using the same basic system as was used for the hydrogen pipeline shown in Figure 13. The system uses almost all of the same pressures, temperatures, and two-stage compressor stations as the hydrogen system. The only difference, besides the different fluid in the system, is the final compressor only compresses the natural gas to 207 bar, and an isentropic efficiency of 70% is used for all compressors in the system.

5.3.2 Analysis Results

The analysis was completed for each system and the results are given for each in Table 19. For each gas, an operational velocity equivalent to 50% of the erosional velocity was used as previously described. However, for the liquid ammonia a lower operational velocity of 45% had to be used since the pressure drop over the 128.8 km pipeline segment would cause the ammonia to vaporize. A lower operational velocity decreases the pressure loss and eliminates this problem. The efficiency for each system is defined as the chemical energy output divided by the sum of both the chemical energy input and work input to the process.

5.3.2.1 Ammonia and Hydrogen Pipeline Systems using a Hydrogen Source

The results of the analysis for both the hydrogen and ammonia pipeline systems can be seen in Table 17. Both systems obtain hydrogen from the same hydrogen supply at 104 bar, and therefore the energy associated with hydrogen production is eliminated from this comparison. The hydrogen is either transported as hydrogen, or converted to ammonia and transported as ammonia. The results show that the ammonia pipeline system energy use is only 9,028 kJ/kg-H₂ while the hydrogen pipeline energy use is significantly more at 21,402 kJ/kg-H₂. The ammonia system also had a higher efficiency than the hydrogen system with calculated efficiency of 93.4% and 86.9%, respectively.

Table 17: Comparison between hydrogen and ammonia pipeline system

	H ₂ Pipeline	NH ₃ Pipeline
Total Energy Input (kJ/kg H ₂)	21,402	9,028
Mass Flow (kg/s H ₂)	8.52	17.73
Work Input (MW)	182	160
Energy Out HHV (MW)	1,207	2,251
Operational Velocity (%)	50.00	45.00
Max Pipeline Velocity (m/s)	31.9	2.2
Min Pipeline Velocity (m/s)	14.0	2.2
Efficiency HHV	86.9%	93.4%
Energy Density (MJ/L)	5.57	14.09

*Ammonia values normalized to hydrogen

The ammonia pipeline also has a hydrogen flow rate nearly double that of the hydrogen pipeline. Further, the energy carrying capacity of the ammonia pipeline is nearly twice that of the hydrogen pipeline at 2,251 MW and 1,207 MW, respectively. This analysis shows that for a given capital investment in pipe, nearly twice the energy can be transported by ammonia, which would result in lower unit costs for transportation.

The difference in energy use between the two systems can further be compared in the graphic provided in Figure 14. The 1,610 km hydrogen pipeline uses 14,814 kJ/kg-H₂ compared to the ammonia system that uses only 1,119 kJ/kg-H₂, or more than an order of magnitude more energy. This difference can be explained due to the states of the two fluids with the hydrogen transported as a gas, which requires compressors, whereas the ammonia was

transported as a liquid, which requires pumps. A pump is considerably more efficient at moving a fluid, resulting in significantly lower energy use.

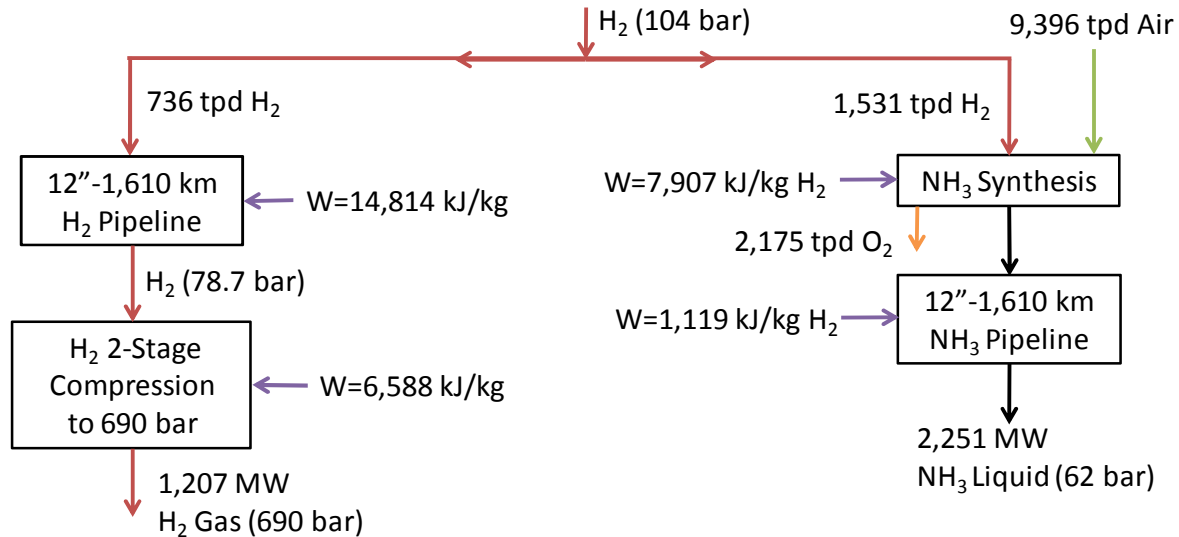

Figure 14: Hydrogen and ammonia pipeline system diagram

The energy to compress the hydrogen to 690 bar is nearly half of the energy required to move the hydrogen 1,610 km (Figure 14) especially since compressing gasses to high pressures is an energy intensive process. Specifically, hydrogen is difficult to compress and high pressure compressors have a lower isentropic efficiency than low pressure compressors. The pressure ratio for the pipeline and final compressors is also much different. In the pipeline, each compressor has a pressure ratio of 1.56 in a two-stage design for a total compression ratio of 2.43. The final compression to 690 bar uses a compression ratio of 2.98 across each compressor for a total compression ratio of 8.88. Although the energy requirement seems high, the calculated value is within the range of values found in the open literature.

Ammonia, in comparison, requires no additional energy at the exit of the pipeline since it is already at a pressure suitable for fueling. Even if additional pressure was required, the pumping energy would be minimal.

Ammonia synthesis, as in the low-temperature storage analysis, is the largest energy loss in the ammonia system. Removing the synthesis loop and by using a 104 bar ammonia source would decrease the pipeline energy use to 1,040 kJ/kg-H₂, which is 79 kJ/kg-H₂ less than what was indicated in Figure 14 since the ammonia is received at a higher pressure.

5.3.2.2 Ammonia Pipeline with Reforming to Hydrogen

Ammonia clearly provides a more efficient method of energy transport than by using hydrogen. However, if hydrogen is needed as the end product from the pipeline, the ammonia would have to be reformed into hydrogen and nitrogen. The system is similar to the previously described ammonia pipeline system with the addition of an ammonia reformer (Figure 15). The reformer is assumed to be 90% efficient in converting the ammonia into hydrogen [76]. It has also been assumed that no pressure losses occur in the reformer.

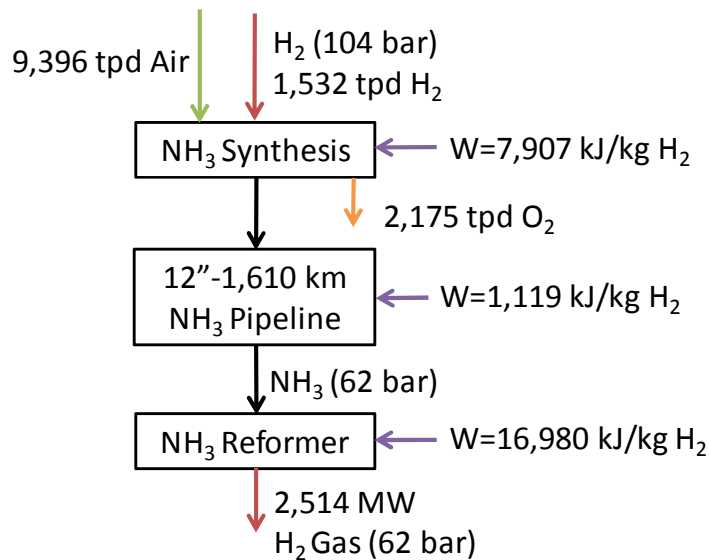

Figure 15: Ammonia pipeline system with conversion to hydrogen

The resulting system with ammonia reforming has a greatly reduced pipeline energy use compared to the hydrogen system, but the losses associated with ammonia reforming make the overall ammonia pipeline and reforming process less efficient than simply transporting hydrogen directly. Specifically, the efficiency of the ammonia with reformer is calculated to be 84.5%, which is less than the hydrogen pipeline efficiency of 86.9%. In addition, the hydrogen gas produced is at a low pressure of 62 bar, and an additional 7,357 kJ/kg-H₂ of energy would be required to bring the hydrogen to 690 bar. Therefore, if hydrogen gas is needed, it is more efficient to use a hydrogen pipeline. Conversely, if the intent is to maximize the amount of energy that can be transported through a pipeline, then using an ammonia pipeline with reforming would be a better option for transporting hydrogen since

the ammonia reforming system has more than twice the energy carrying capacity of a hydrogen pipeline system.

5.3.2.3 Ammonia Compared to Compressed Natural Gas

Compressed natural gas as a substitute for gasoline is being promoted by a number of entities including the Pickens Plan, which is an effort initiated by T. Boone Pickens to increase wind energy use in the United States and to run vehicles on natural gas [68]. The idea is to use wind turbine generators to produce electricity and displace some of the natural gas currently used for electricity generation. The natural gas would then be used as a vehicle fuel to reduce gasoline usage and provide a relatively clean transportation fuel, although the combustion of methane would still release carbon dioxide during combustion. Because of the potential for using natural gas as a transportation fuel, the efficiency of transporting natural gas and compressing it to fueling pressure was added to this analysis in order to compare it to ammonia and hydrogen.

The methane pipeline system can be directly compared to an ammonia pipeline without the ammonia synthesis as shown in Figure 16. Methane undergoes reforming after exiting a well before the natural gas product is sent to consumers. This analysis only compares the energy to move the finished product 1,610 km for use as a vehicle fuel, and therefore ammonia is compared directly to the natural gas pipeline.

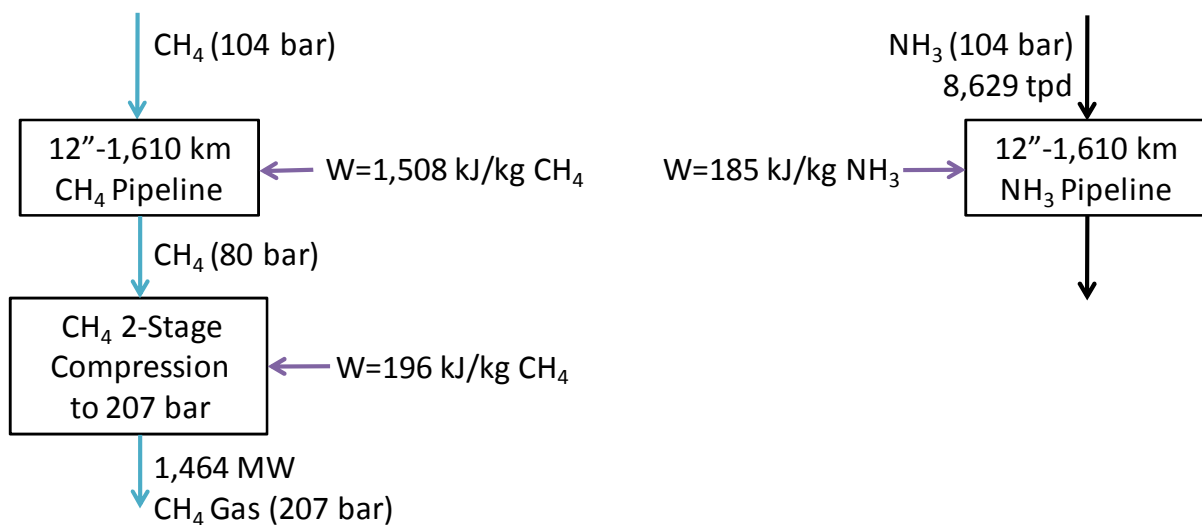

Figure 16: Diagram of methane and ammonia pipeline system

The results in Table 18 show that the ammonia pipeline uses 185 kJ/kg-NH₃, whereas the methane pipeline uses 1,704 kJ/kg-CH₄. It should be noted that the energy use value for ammonia is reported in units of kilograms of ammonia, unlike other sections of this paper where it has been reported as kilograms of hydrogen in the ammonia. The energy use per kilogram does not allow for an equal comparison due to the difference in energy content of the two fuels. However, the efficiency can still be compared, which is defined as the chemical energy output divided by the sum of both the chemical energy input and the work input to the system. The efficiency of the methane system is 97.0%, which is high considering that the final compression to fueling pressure is also included in the calculation. The ammonia pipeline efficiency is even higher at 99.2%. In comparison, the hydrogen pipeline system efficiency is the lowest at only 86.9%. The difference in efficiency is caused by the energy savings involved with pumping a fluid compared to compression.

Table 18: Energy use in the methane and ammonia pipeline systems

	CH ₄ Pipeline	NH ₃ Pipeline
Total Energy Input (kJ/kg)	1,704	185
Mass Flow (kg/s)	26.37	99.87
Work Input (MW)	45	18
Energy Out HHV (MW)	1,464	2,251
Operational Velocity (%)	50.00	45.00
Max Pipeline Velocity (m/s)	10.3	2.2
Min Pipeline Velocity (m/s)	4.2	2.2
Efficiency HHV	97.0%	99.2%
Energy Density (MJ/L)	9.73	14.09

Other important values shown in Table 16 are the amount of energy that is transported and the energy density. Even though both systems use the same pipeline and same number of compression stations, the ammonia pipeline is able to transport 54% more energy than the natural gas pipeline. This difference is important because it shows that converting an existing natural gas pipeline to transport ammonia could increase the energy transporting capacity of the pipeline. In addition, the energy density of the ammonia is higher than the compressed natural gas by a factor of 1.45, and therefore for vehicle storage of fuel, less volume would be required for an ammonia tank than for a compressed natural gas tank. The

ammonia is also stored at a modest pressure of 17 bar, unlike CNG that is stored at 207 bar, which would require a much stronger and heavier fuel tank.

5.3.2.4 Summary of Pipeline Transport

Pipelines provide an efficient transportation solution and can move large quantities of fuel. The complete results for the analysis of pipeline transport are shown in Table 19. From this table and the previous discussion, it can be seen that ammonia and natural gas are both more efficient fluids to transport through a pipeline and use as vehicle fuel than hydrogen, even when the ammonia synthesis is included in the analysis. Natural gas is more efficient than hydrogen, but it is a carbon containing fuel that releases greenhouse gasses during combustion.

Table 19: Pipeline analysis results

	H ₂ Pipeline	Synthesis & NH ₃ Pipeline*	NH ₃ Pipeline & Reformer*	CH ₄ Pipeline	NH ₃ Pipeline
Total Energy Input (kJ/kg)	21,402	9,028	26,008	1,704	185
Mass Flow (kg/s)	8.52	17.73	17.73	26.37	99.87
Work Input (MW)	182	160	461	45	18
Energy Out HHV (MW)	1,207	2,251	2,514	1,464	2,251
Operational Velocity (%)	50	45	45	50	45
Max Pipeline Velocity (m/s)	31.9	2.2	2.2	10.3	2.2
Min Pipeline Velocity (m/s)	14.0	2.2	2.2	4.2	2.2
Efficiency HHV	86.9%	93.4%	84.5%	97.0%	99.2%
Energy Density (MJ/L)	5.57	14.09	0.70	9.73	14.09

*Ammonia values normalized to hydrogen

The energy density of a fuel is important since it affects the quantity that can be stored in a given space on a vehicle. The fuel with the highest energy density is ammonia with 14.09 MJ/L, followed by natural gas at 9.73 MJ/L. The lowest energy density fuel is hydrogen at 690 bar with an energy density of 5.57 MJ/L. In comparison, gasoline has an energy content of 34.8 MJ/L, and therefore all of these fuels are less energy dense than gasoline. It should be noted that the volume of current on-board fuel storage tanks would need to be increased by the least amount if ammonia is used as a transportation fuel compared to other alternative fuel choices.

For any pipeline analysis, the flow rate in the pipeline is a critical variable. Increasing flow rates allows more fluid to be moved, but pressure losses and energy consumption both

increase. Conversely, decreasing flow rate reduces energy use, but less fuel is transported. This is an operational constraint that would need to be accounted for in order to find the most economic operating point for the system.

5.3.3 Pipeline System Costs

The main operating cost component for a pipeline is the initial capital cost for installation [71]. The pipeline analysis used the same type of pipe material and length for each fluid transported, therefore the cost for the pipeline itself and the associated right-of-way should be the same for each of the calculations. The same number of booster stations was also assumed for each pipeline. The hydrogen compressors will be more expensive than the methane compressors and ammonia pumps, and therefore the hydrogen pipeline will have the highest capital cost. The end use requires compression for hydrogen and natural gas, which is a higher cost compared to ammonia, which requires no additional pumping at the point of end use.

The energy cost can easily be calculated based on the energy requirements for each pipeline. The difference between the systems can then be compared and the most energy intensive system will be the most expensive to operate. For example, it would cost 0.476 \$/kg-H₂ to transport and compress hydrogen if an electricity cost of 0.08 \$/kWh is used. Ammonia could be synthesized and transported for 0.201\$/kg-H₂ if the same electricity cost is used. If the ammonia synthesis is eliminated from the system, the cost for pipeline transportation would only be 0.023 \$/kg-H₂.

Actual pipeline costs are difficult to estimate due to differences in terrain and population density along the pipeline route. Natural gas pipeline installed costs varied between 131,700 and 1,243,000 \$/km in 1995 dollars depending on the pipeline parameters and location [63]. These costs are representative of what could be expected with a new pipeline since the pipeline used in this analysis used a similar pressure and operating condition as existing natural gas pipelines.

There are several studies that have estimated the cost of hydrogen transport via pipeline. A report by Amos provided a cost of 0.90-1.20 \$/kg for a 3,300 km pipeline [63], which would

cost approximately 0.51 \$/kg for a 1,610 kilometer pipeline in 2007 dollars. A study by Yang and Ogden gives the cost at about 1.00 \$/kg for a 500 km pipeline [71] or about 3.22 \$/kg for a 1,610 km distance in 2007 dollars. The costs are clearly much different and the differences can be explained by the different assumptions that were used in each analysis.

Ammonia is currently transported by using pipelines, and therefore commercial tariffs for transporting ammonia are presently available from the pipeline operators. The commercial price to transport ammonia between Donaldsonville, Louisiana and Marshalltown, Iowa via pipeline, a distance of approximately 1,610 km, is 31.22 \$/short ton or 0.0344 \$/kg-NH₃ [77]. Adjusting this cost to hydrogen gives a cost of 0.194 \$/kg-H₂ for existing pipelines. If a new pipeline is installed, the cost may increase, but overall the cost is about one-third of the lowest estimate for hydrogen pipeline transportation cost.

5.4 Summary

Any transportation fuel needs to have a low-cost and energy-efficient distribution network in order to transport the fuel to consumers. The analysis herein found that ammonia is a more efficient energy-carrier compared to hydrogen when it is transported either in a storage vessel or pipeline. Ammonia is also easier to handle since it is a liquid at a moderate pressure of 17 bar, unlike hydrogen which is either a low-density gas or a higher-density refrigerated liquid at -253°C.

Transporting fuel in discreet quantities, such as with a tanker truck, shows how the lower steel requirements and higher energy density of ammonia combine to provide significant advantages for ammonia over hydrogen fuel transport. The high pressures involved with hydrogen gas transportation limit the carrying capacity of a semi tractor-trailer to 340 kg of hydrogen or 48 GJ of energy, whereas the ammonia tanker can carry 26,600 kg of ammonia or 600 GJ of energy. Transporting hydrogen as a liquid improves the carrying capacity of a semi-trailer to 3,900 kg or 553 GJ. However, liquefaction of hydrogen is an energy intensive process and significantly more energy would be required for liquefied hydrogen transport than ammonia transport.

Pipeline transport analysis shows that ammonia is the most efficient transportation fuel when moved through a pipeline compared to both hydrogen and natural gas. The efficiency of a 1,610 km ammonia pipeline is 93.4% including the synthesis of ammonia from a hydrogen source. Without considering synthesis, the ammonia efficiency is 99.2%. For both cases, ammonia is delivered as a liquid at sufficient pressure for vehicle fueling. Natural gas, if transported over the same distance and then compressed to 207 bar for a vehicle fuel, has an efficiency of 97.0%. The lowest efficiency was found with the hydrogen pipeline system that included final compression to 690 bar for use in a vehicle, which had an overall efficiency of 86.9%. The energy carrying capacity of the pipelines was also much higher with ammonia in that a 12 inch nominal ammonia pipeline is capable of transporting 2,251 MW of energy, whereas the natural gas and hydrogen pipeline can only transport 1,464 MW and 1,207 MW, respectively for the same pipe

Ammonia also had a lower cost of pipeline transport than hydrogen with estimated cost for the hydrogen pipeline transportation to be between 0.51 and 3.22 \$/kg for a 1,610 km distance. Ammonia is currently transported in commercial pipelines over a distance of 1,610 km for 0.0344 \$/kg-NH₃ (0.194 \$/kg-H₂). From these cost estimates, ammonia is nearly three times cheaper to transport than hydrogen.

CHAPTER 6. AN ECONOMIC COMPARISON BETWEEN AMMONIA AND HYDROGEN TRANSPORTATION FUELS

An Ammonia Economy can provide the same benefits as a Hydrogen Economy, which includes a diversified energy source, domestic energy production, and no carbon emissions during fuel combustion. Ammonia also provides the added benefits of an easily stored and transported liquid compared to the relative difficulty of handle hydrogen. Although ammonia is a slightly more expensive fuel due to the additional processing required for synthesis compared to hydrogen, the higher efficiency and lower cost of transportation and storage ultimately gives ammonia an economic advantage over hydrogen.

6.1 Comparing Hydrogen and Ammonia Costs

Ammonia is a fuel synthesized from hydrogen and nitrogen, and therefore ammonia will cost more than hydrogen due to the additional processing and capital equipment required for production. This higher cost is unavoidable unless a method is commercially developed to produce ammonia without the intermediate step of producing hydrogen, such as solid state ammonia synthesis described in Section 3.1.3 of this paper.

This cost for conversion of hydrogen to ammonia was determined in Chapter 3, where it was found to be 141.65 \$/t for a large 2,200 t/day plant with a gas turbine and ASU (Table 11). This cost is equivalent to an additional production cost of 0.80 \$/kg-H₂. For a conventional natural-gas ammonia plant, the capital cost is only 76.48 \$/t for the same size plant since an ASU and gas turbine are not needed, and as a result the cost of conversion is 0.43 \$/kg-H₂.

The cost of ammonia is highly dependent on the cost of hydrogen, and therefore low-cost hydrogen sources are also low-cost ammonia sources. For example, the lowest cost source of hydrogen was found to be coal with an estimated cost with sequestration between 0.36 and 1.83 \$/kg-H₂, which corresponds with the lowest cost source of ammonia, estimated to be between 147 \$/t and 432 \$/t for coal.

6.2 Alternative Energy Sources of Ammonia

The sources with the highest costs for ammonia were found to be from alternative energy sources. The reason for this higher cost is mostly due to the higher cost of hydrogen production from alternative energy sources. Since hydrogen is the main cost contributor to the cost of ammonia, alternative energy sources of hydrogen are the highest cost ammonia sources. However, advancements in electrolyzer and thermochemical cracking of water could help to decrease the cost of hydrogen from alternative fuels. In addition, lower-cost alternative technologies currently being researched and commercialized, such as thin-film solar panels, may further reduce the cost of hydrogen from alternate fuel sources.

Alternative energy sources also tend to be smaller than natural gas and coal plants. Therefore, economies of scale are not always achieved in these alternative fuel plants, and as a result the conversion cost to produce ammonia is higher. For example, a 2,200 t/day plant with air separation unit and gas turbine would have a capital cost of 141.65 \$/t, but a small 200 t/day plant would have a higher cost of 327.87 \$/t (Table 12). Most alternative fuel sources also require the use of an air separation unit for a nitrogen supply and a gas turbine to account for the intermittent operation. Consequently, the capital cost of ammonia synthesis plant with alternative energy is 85% higher than a natural gas plant producing ammonia, which would only require the Haber-Bosch synloop.

6.3 Total Estimated Production, Storage, and Transportation Cost

The total cost for a fuel includes the production cost along with the transportation and storage cost. For the production cost, hydrogen at 3.00 \$/kg is assumed. By using a 2,200 t/day ammonia plant with an ASU and gas turbine, ammonia can be produced for a cost of 3.80 \$/kg-H₂ from a 3.00 \$/kg-H₂ hydrogen source. The cost for storage and transport of the two fuels was analyzed in Chapter 4 and 5, respectively, and are shown along with the production cost in Table 20. The cost for pipeline transport of hydrogen was taken as the average cost between the two values found in the studies.

Table 20: Production, storage, and transportation cost for hydrogen and ammonia

	Hydrogen (\$/kg H ₂)	Ammonia (\$/kg H ₂)*
Production	3.00	3.80
Pipeline Transport	1.87	0.19
Storage		
182 Day	14.95	0.54
15 Day	1.97	0.06

*Ammonia values normalized to hydrogen

It can immediately be seen from Table 20 that the cost of ammonia is higher than hydrogen, as is expected due to the additional processing required to make ammonia. If the fuel is to be transported, an additional cost of 1.87 \$/kg-H₂ and 0.19 \$/kg-H₂ is added for hydrogen and ammonia, respectively. Even though ammonia has a higher production cost, the combined production and transportation costs shown in Figure 17 makes ammonia 0.88 \$/kg-H₂ cheaper than hydrogen.

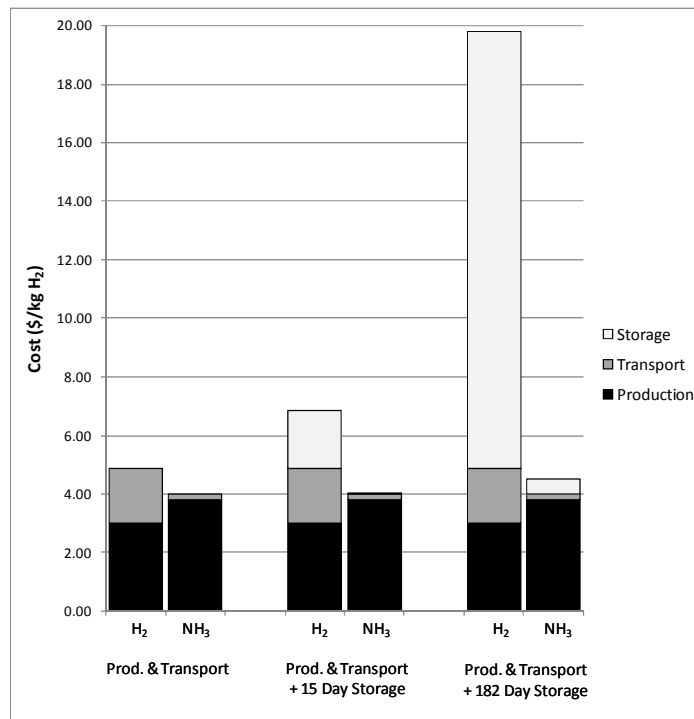
**Figure 17: Total cost for hydrogen and ammonia production, storage, and transport**

The difference in cost between hydrogen and ammonia is even more evident when storage is included with the production and transportation cost. Sometimes fuel will not require large-scale long-term storage and will be used as soon as it is produced and transported to consumers. However, if storage is needed, the cost of storage makes hydrogen more

expensive than ammonia by 2.79 $\$/\text{kg-H}_2$ and 15.28 $\$/\text{kg-H}_2$ for 15 and 182 day storage, respectively. In all cases with either storage or transport costs included, ammonia is more economical than hydrogen.

6.4 Existing Infrastructure for an Ammonia Economy

A distribution network is already in place for ammonia since it is currently used as a fertilizer for agriculture. For example, as shown in Figure 11 a 4,830 km commercial pipeline system exists in the United States to transport ammonia between ports, production facilities, and end users in the agricultural areas. The distribution network also contains more than 800 retail distribution locations along with large-scale low-temperature storage facilities. There are also ships, barges, semi-trailer tankers, and rail cars in use to distribute ammonia between the producers and consumers in places that do not have a pipeline nearby.

Hydrogen has relatively little infrastructure in place compared to ammonia. For example, there are only 719 km of hydrogen pipeline currently in the United States that are used for hydrogen transport between industrial locations. This lack of hydrogen infrastructure is certainly a challenge to implementing the Hydrogen Economy.

6.5 Summary

Ammonia as a transportation fuel provides added benefits over a Hydrogen Economy, even though the production cost for ammonia is slightly higher than for hydrogen. For example, if hydrogen is available for 3.00 $\$/\text{kg-H}_2$, the equivalent cost of ammonia is 3.80 $\$/\text{kg-H}_2$. However, the ease of transporting and storing ammonia makes the overall cost of ammonia as a transportation fuel considerably less than that of hydrogen. For instance, if the cost of 1,610 km of transport is included in the comparison, the fuel cost is 3.99 $\$/\text{kg-H}_2$ and 4.96 $\$/\text{kg-H}_2$ for ammonia and hydrogen, respectively, which makes ammonia a lower cost fuel. If 182 days of storage is added to the cost, then ammonia is even cheaper relative to hydrogen with a cost of 4.53 $\$/\text{kg-H}_2$ and 19.91 $\$/\text{kg-H}_2$ for ammonia and hydrogen, respectively. In addition, there is an existing ammonia distribution network in place for handling ammonia in fertilizer applications, and as a result, the Ammonia Economy has both a cost and infrastructure advantage over a Hydrogen Economy.

CHAPTER 7. CONCLUSIONS

An alternative transportation fuel is needed to eliminate the use of oil, which in turn will overcome future fuel shortages and reduce greenhouse gas emissions. Two carbonless transportation fuels, namely hydrogen and ammonia, were analyzed in this study to determine production, storage, and transportation cost and energy use for both fuels. The results show that ammonia is a lower cost and more efficient fuel than hydrogen. In addition, there is significant ammonia infrastructure in place for fertilizer use, which will allow for faster development of the Ammonia Economy compared to the Hydrogen Economy.

The cost of ammonia production was determined from energy resources including natural gas, coal, nuclear, solar, wind, OTEC, and biomass. The lowest cost ammonia source was found to be coal, with estimated ammonia production costs of 147-432 \$/t including carbon sequestration. The equivalent cost of gasoline based on this ammonia price is 0.96-2.83 \$/gal, which is competitive with recent gasoline prices of 2.00-4.00 \$/gal. Other low cost sources of ammonia include natural gas and possibly OTEC, with the latter being based on theoretical studies rather than an actual installation. Even though alternative energy sources had the highest cost for ammonia production, technology advancements are decreasing the cost of hydrogen and ammonia from alternative energy resources while the cost of fossil fuel is increasing, which could make alternative energy sources economical in the future.

The most efficient and low cost method to store large quantities of alternative fuel was found to be low-temperature storage. The ammonia system was found to have the highest efficiency of 93.6%, including the energy for ammonia synthesis, for 182 days of storage, whereas the hydrogen efficiency was only 76.9% for the same storage period. The combined capital and operating cost for 182 days of storage was found to be 14.95 \$/kg-H₂ and 0.54 \$/kg-H₂ for hydrogen and ammonia, respectively.

A pipeline transport analysis was completed for both fuels, which showed that the ammonia pipeline system has a much higher efficiency than the hydrogen pipeline system, with the results being 93.4% and 86.9%, respectively. The ammonia pipeline was also able to carry nearly twice the energy for an assumed pipe diameter. In addition, cost estimates showed

that ammonia pipeline transportation over 1,610 km is cheaper with an equivalent transportation cost of 0.194 \$/kg-H₂ whereas hydrogen had a cost of 0.51-3.22 \$/kg-H₂ for the same distance.

Combining these costs into a total production, storage, and delivery cost showed ammonia has a significant cost advantage over hydrogen. Specifically, if hydrogen is available for 3.00 \$/kg-H₂, then the total cost of production, storage for 182 days, and 1,610 km of pipeline transport is 19.91 \$/kg-H₂ and 4.53 \$/kg-H₂ for hydrogen and ammonia respectively. In addition to the cost advantage of ammonia, there is also an existing distribution network in place for transporting ammonia fertilizer, and therefore the Ammonia Economy can be developed at a faster pace and for a lower cost than a Hydrogen Economy.

BIBLIOGRAPHY

1. Appl M. Ammonia: principles and industrial practice. Weinheim, 1999.
2. Curry Hydrocarbons Inc. Chemical Engineering Plant Cost Index. <http://ca.geocities.com/fhcurry@rogers.com/>. Retrieved July 12, 2008.
3. Stiegel G & Massood R. Hydrogen from coal gasification: an economical pathway to a sustainable energy future. *Int J of Coal Geology* (2006) 65:173-190.
4. BP. Statistical Review of World Energy 2008 (Jun, 2008). <http://www.bp.com/productlanding.do?categoryId=6929&contentId=7044622>. Retrieved June 22, 2008.
5. Gray D & Tomlinson G. Hydrogen from coal. Mitretek. (2002) MTR 2002-31.
6. Energy Information Administration. U.S. Natural Gas Prices (May, 2008). http://tonto.eia.doe.gov/dnav/ng/ng_pri_sum_dcu_nus_m.htm. Retrieved June 23, 2008.
7. Penner S. Steps toward the hydrogen economy. *Energy* (2006) 31:33-43.
8. Rutkowski M. Current (2005) hydrogen from SMR natural gas with CO₂ capture and sequestration (Jun, 2005). http://www.hydrogen.energy.gov/h2a_prod_studies.html. Retrieved March 7, 2008.
9. Rutkowski M. Current (2005) hydrogen from natural gas without CO₂ capture and sequestration (Jun, 2005). http://www.hydrogen.energy.gov/h2a_prod_studies.html. Retrieved March 7, 2008.
10. World Coal Institute. How coal is created (2008). <http://www.worldcoal.org/pages/content/index.asp?PageID=98>. Retrieved February 10, 2008.
11. Kreutz T, Williams R, Consonni S. et al. Co-production of hydrogen, electricity and CO₂ from coal with commercially ready technology. part b: economic analysis. *Int J of Hydrogen Energy* (2005) 30:769-784.
12. Rutkowski M. Current (2005) hydrogen from coal without CO₂ capture and sequestration (Jun, 2005). http://www.hydrogen.energy.gov/h2a_prod_studies.html. Retrieved March 7, 2008.
13. Rutkowski M. Current (2005) hydrogen from coal with CO₂ capture and sequestration (Jun, 2005). http://www.hydrogen.energy.gov/h2a_prod_studies.html. Retrieved March 7, 2008.
14. World Nuclear Association. Supply of uranium. <http://www.world-nuclear.org/info/inf75.html>. Retrieved June 23, 2008.

15. Henderson D & Taylor A. The US Department of Energy research and development programme on hydrogen production using nuclear energy. *Int J of Nuclear Hydrogen Production and Application* (2006) 1:51-56.
16. Ryazantsev E & Chabak A. Hydrogen production, storage, and use at nuclear power plants. *Atomic Energy* (2006) 101:876-881.
17. Petri M, Bilge Y & Klickman A. US work on technical and economic aspects of electrolytic, thermochemical, and hybrid processes for hydrogen production at temperatures below 550C. *Int J of Nuclear Hydrogen Production and Application* (2006) 1:79-91.
18. Schultz K. Use of the modular helium reactor for hydrogen production. *World Nuclear Association Annual Symposium, September 3-5, 2003.* (2003):1-11.
19. Richards M, Shenoy A, Schultz K. et al. H₂-MHR conceptual designs based on the sulphur-iodine process and high-temperature electrolysis. *Int J of Nuclear Hydrogen Production and Applications* (2006) 1:36-50.
20. El-Wakil M. *Powerplant technology.* McGraw-Hill, 1984.
21. Energy Information Administration. *International Total Primary Energy Consumption and Energy Intensity.*
<http://www.eia.doe.gov/emeu/international/energyconsumption.html>. Retrieved January 10, 2008.
22. Glatzmaier G, Blake D & Showalter S. *Assessment of methods for hydrogen production using concentrated solar energy.* NREL. (1998) NREL/TP-570-23629.
23. Solarbuzz. *Portal to the world of solar energy* (2008).
<http://www.solarbuzz.com/index.asp>. Retrieved January 11, 2008.
24. Bockris JO & Veziroglu TN. Estimates of the price of hydrogen as a medium for wind and solar sources. *Int J of Hydrogen Energy* (2007) 32:1605-1610.
25. Roscheisen M. *Nanosolar ships first panels* (Dec, 2007).
<http://www.nanosolar.com/blog3/2007/12/18/nanosolar-ships-first-panels/>. Retrieved January 11, 2008.
26. Kolb GJ, Diver RB & Siegel N. Central-station solar hydrogen power plant. *J of Solar Energy Engineering* (2007) 129:179-183.
27. Giaconia A, Grena R, Lanchi M. et al. Hydrogen/methanol production by sulfur-iodine thermochemical cycle powered by combined solar/fossil energy. *Int J of Hydrogen Energy* (2007) 32:469-481.
28. AWEA. *Top 20 States with Wind Energy Resource Potential* (2008).
<http://www.awea.org/pubs/factsheets.html>. Retrieved February 28, 2008.

29. Sherif S, Barbir F & Veziroglu T. Wind energy and the hydrogen economy - review of the technology. *Solar Energy* (2005) 78:647-660.
30. Levene J, Kroposki B & Sverdrup G. Wind energy and production of hydrogen and electricity - opportunities for renewable hydrogen. NREL. (2006) NREL/CP-560-39534.
31. Levene JI. Current (2005) Hydrogen generation from wind with electricity co-production (2005). http://www.hydrogen.energy.gov/h2a_prod_studies.html. Retrieved March 4, 2008.
32. Levene JI. Current (2005) hydrogen generation from wind (2005). http://www.hydrogen.energy.gov/h2a_prod_studies.html. Retrieved March 4, 2008.
33. Ni M, Leung DY, Leung MK. et al. An overview of hydrogen production from biomass. *Fuel Processing Technology* (2006) 87:461-472.
34. Albertazzi S, Basile F, Brandin J. et al. The technical feasibility of biomass gasification for hydrogen production. *Catalysis Today* (2005) 106:297-300.
35. Searchinger T, Heimlich R, Houghton RA. et al. Use of U.S. croplands for biofuels increases greenhouse gases through emissions from land use change. *Science* (2008) 319:1238-1240.
36. Fargione J, Hill J, Tilman D. et al. Land clearing and the biofuel carbon debt. *Science* (2008) 319:1235-1238.
37. Baumlin S, Broust F, Bazer-Bachi F. et al. Production of hydrogen by lignins fast pyrolysis. *Int J of Hydrogen Energy* (2006) 31:2179-2192.
38. Demirbas MF. Hydrogen from various biomass species via pyrolysis and steam gasification processes. *Energy Sources* (2006) 28:245-252.
39. Padro CEG & Putsche V. Survey of the economics of hydrogen technologies. NREL. (1999) NREL/TP-570-27079.
40. Mann MK. Current (2005) hydrogen from biomass via gasification and catalytic steam reforming (Jan, 2005). http://www.hydrogen.energy.gov/h2a_prod_studies.html. Retrieved March 4, 2008.
41. Benemann JR. Hydrogen production by microalgae. *Applied Phycology* (2000) 12:291-300.
42. Benemann J. Feasibility analysis of photobiological hydrogen production. *Int J Hydrogen Energy* (1997) 22:979-987.
43. Hallenbeck PC & Benemann JR. Biological hydrogen production; fundamentals and limiting processes. *Int J of Hydrogen Energy* (2002) 27:1185-1193.

44. U.S. Department of Energy NREL. PV FAQs (Feb, 2004). <http://www.nrel.gov/docs/fy04osti/35097.pdf>. Retrieved January 11, 2008.
45. Galvez M, Halmann M & Steinfeld A. Ammonia production via a two-step AL_2O_3/ALN thermochemical cycle. 1. thermodynamic, environmental, and economic analyses. *Ind. Eng. Chem. Res.* (2007) 46:2042-2046.
46. Rossetti I, Pernicone N & Forni L. Graphitised carbon as support for Ru/C ammonia synthesis catalyst. *Catalysis Today* (2005) 102-103:219-224.
47. Jennings J. *Catalytic ammonia synthesis: fundamentals and practice*. Plenum Press, 1991.
48. Ganley J, Holbrook J & McKinley D. Solid state ammonia synthesis. Oct, 2007. Presented at the Ammonia - Sustainable Emission-Free Fuel Conference, San Francisco, CA. October 15-16, 2007.
49. Dittus M & Johnson D. Dakota gasification company Great Plains Synfuels plant: the hidden value of lignite coal. 2001. Presented at the 2001 Gasification Technologies Conference.
50. CVR Energy Inc. Nitrogen Fertilizer Operations (2007). <http://www.cvrenergy.com/nitrogenMain.aspx>. Retrieved February 28, 2008.
51. Li Z. Coal-based ammonia plants, new technology and trend in ammonia production in China. Apr, 2004. Presented at the 2004 IFA Technical Conference, Beijing, China. April 20-23, 2004.
52. Tse D. Ammonia from coal. Oct, 2006. Presented at the Ammonia - The Key to US Energy Independence Conference, Golden, CO. October 9-10, 2006.
53. Reese M. Wind to ammonia: an update. Oct, 2007. Presented at the Ammonia - Sustainable Emission-Free Fuel Conference, San Francisco, CA. October 15-16, 2007.
54. Avery WH, Richards D & Dugger GL. Hydrogen generation by OTEC electrolysis, and economical energy transfer to world markets via ammonia and methanol. *Int J Hydrogen Energy* (1985) 10:727-736.
55. Waid RL. The mini-OTEC test. *Oceans* (1979) 11:548-552.
56. Avery WH & Berl WG. Solar energy from the tropical oceans. *Int J of Hydrogen Energy* (1999) 24:295-298.
57. Van Ryzin J, Grandelli P, Lipp D. et al. The hydrogen economy of 2050: OTEC driven?. *Oceans* (2005) 3:2675-2682.
58. Messer Group GmbH. This is how air separation works. <http://www.messergroup.cn/Products/down/LZAEnglisch.pdf>. Retrieved June 21, 2008.

59. Gosnell J. Efficient ammonia production. Oct, 2005. Presented at the Ammonia - The Key to the Hydrogen Economy Conference, Argonne, IL. October 9-10, 2005.
60. GRAC. GRAC - natural gas simple-cycle gas turbine power plants (May, 2002) . <http://www.nwcouncil.org/energy/powerplan/grac/052202/gassimple.htm>. Retrieved August 12, 2008.
61. Personal communication with Keith Stokes, Stokes Engineering. April 2008.
62. MacKenzie JJ & Avery WH. Ammonia fuel: the key to hydrogen-based transportation. Energy Conversion Engineering Conference, 1996. IECEC 96. Proceedings of the 31st Intersociety (1996) 3:1761-1766.
63. Amos WA. Costs of storing and transporting hydrogen. NREL. (1998) NREL/TP-570-25106.
64. Webb D. Large Scale Ammonia Storage and Handling. www.irc.wisc.edu. Retrieved August 20, 2008.
65. Belapurkar V. Boil-Off in Refrigerated Ammonia Tanks. <http://www.cheresources.com/refnh3tanks.shtml>. Retrieved August 20, 2008.
66. Drnevich R. Hydrogen delivery liquefaction & compression. May, 2003. Presented at the Strategic Initiatives for Hydrogen Delivery Workshop. May 7, 2003.
67. Budget estimating information for ammonia and hydrogen storage system provided to Iowa Energy Center. CB&I. March 8, 2006.
68. PickensPlan (2008). <http://www.pickensplan.com/index.php>. Retrieved September 13, 2008.
69. Minnesota Department of Agriculture. Anhydrous ammonia transportation information (2007) . <http://www.mda.state.mn.us/chemicals/spills/ammoniaspills/transportation.htm>. Retrieved February 21, 2008.
70. Paster M. Hydrogen deliver options and issues. http://www1.eere.energy.gov/hydrogenandfuelcells/analysis/pdfs/paster_h2_delivery.pdf. Retrieved February 21, 2008.
71. Yang C & Ogden J. Determining the lowest-cost hydrogen delivery mode. *Int J Hydrogen Energy* (2007) 32:268-286.
72. Ammonia Fuel Network . <http://www.ammoniafuelnetwork.org/index.html>. Retrieved September 16, 2008.
73. Gillette JL & Kolpa RL. Overview of interstate hydrogen pipeline systems. Argonne National Laboratory. (2007) ANL/EVS/TM/08-2.

74. NaturalGas.org. The transportation of natural gas.
<http://www.naturalgas.org/naturalgas/transport.asp>. Retrieved September 15, 2008.
75. Menon ES. Gas pipeline hydraulics. Taylor & Francis Group, 2005.
76. Personal communication with Jason Ganley, Howard University. September 2008.
77. NuStar Pipeline Operating Partnership, L.P. Local tariffs applying on anhydrous ammonia (2008).
<http://www.nustarenergy.com/Customers/Ammonia%20SystemTariff/STB%20No%203%20and%20LPSC%20No.3.pdf>. Retrieved September 13, 2008.

ACKNOWLEDGEMENTS

I would like to take this opportunity to thank those who have assisted me throughout my graduate education and provided input and help during the writing of my thesis. First, I would like to thank Dr. Michael Pate for all of his insight and technical assistance with the preparation of the research presented in my thesis. Dr. Pate has been instrumental in my graduate studies and I have learned so much from him that will help me throughout my career. I would also like to thank my committee members, Dr. Ron Nelson and Dr. Gap-Yong Kim, who have provided invaluable input and help as I worked to complete my thesis.

I would also like to thank my family for their constant support and encouragement throughout my life.

In addition, I would like to thank the Iowa Energy Center for their financial support of this project. All of work presented in this thesis was funded by the Iowa Energy Center Grant 07S-01.