

5-2006

Preservation of Deteriorated Documents Manual

Hilary T. Seo

Iowa State University, hseo@iastate.edu

Carie M. McGinnis

Iowa State University

Follow this and additional works at: http://lib.dr.iastate.edu/pres_workshops

 Part of the [Art and Materials Conservation Commons](#), [Book and Paper Commons](#), [Evidence Commons](#), and the [Library and Information Science Commons](#)

Recommended Citation

Seo, Hilary T. and McGinnis, Carie M., "Preservation of Deteriorated Documents Manual" (2006). *Preservation Outreach and Workshops*. 6.

http://lib.dr.iastate.edu/pres_workshops/6

This Book is brought to you for free and open access by the Preservation Department at Iowa State University Digital Repository. It has been accepted for inclusion in Preservation Outreach and Workshops by an authorized administrator of Iowa State University Digital Repository. For more information, please contact digirep@iastate.edu.

Preservation of Deteriorated Documents Manual

MAFS QD Workshop
May 10-12, 2006
Ankeny, Iowa

by
Hilary T. Seo, Asst. Professor & Head of Preservation
Carie M. McGinnis, Lennox Foundation Intern

Illustrations by Hilary T. Seo

Contents

Page

2. Contents
3. Abstract
4. Fastener removal
5. Tape removal—mechanical
6. Tape removal—chemical vapor fuming
7. Tape removal—Fuller's earth
8. Tape removal—methyl cellulose poultice & goo removal
9. Vacuuming—through a screen
10. Vacuuming—brushing into vacuum
11. Dry cleaning—dry cleaning sponge
12. Dry cleaning—eraser crumbs & block eraser
13. Washing
14. Washing—unfolding & separating pages
15. Tear mending—archival tape
16. Tear mending—heat-set tissue
17. Backing with tissue—heat-set tissue
18. Backing with tissue—methyl cellulose & tissue
21. Tape encapsulation
23. Modified sink mat

Abstract

- The preservation techniques covered during the workshop included basic non-aqueous and aqueous cleaning procedures such as vacuuming, brushing, dry cleaning, and washing. Simple backing, tear mending, tape removal, and re-housing procedures were also addressed. Proper selection of treatments was encouraged by stressing that students should begin with more innocuous treatment options before implementing more aggressive and invasive options. Several treatment options were developed to deal with specific situations common to the field of questioned documents. These include: a methyl cellulose backing technique, and a modified sink mat. Methods for consolidating charred paper fragments were also explored. Remember to test all documents for water soluble inks and media before implementing any of these procedures.

Fastener removal

- **Fastener removal:** see also *Preserving Archives and Manuscripts* Appendix D in handouts
- **Supplies:** micro-spatula, Mylar scraps, small scissors
 1. Cut rubber bands with scissors; do not try to remove intact.
 2. If rubber band is dried on, carefully try to remove (pop off) using micro-spatula.
 3. Staples and paperclips should be unbent to remove.
 4. Use a micro-spatula to lift legs of the staple and then slide the micro-spatula under the body of the staple to remove.
 5. Slip a pieces of Mylar between the paper and paperclip (both sides) and slide paperclip off, or use a micro-spatula to open a metal paperclip and remove.

Tape removal

- **Tape adhesives** can be made with either synthetic or water soluble adhesives. By far most tapes such as duct tape, masking tape, and scotch tape will use a synthetic adhesive. Paper tapes typically use water soluble adhesives. Test for which kind of adhesive a tape has and then choose a tape removal technique accordingly.
- **Supplies:** blotter, cloth covered weights, paper knife or scalpel, heat source, Fuller's earth, toluene, Petri dish, micro-spatula, glass weights, soft haired brush, 50mL and 500mL beakers, paper pulp, rubber cement pick up eraser and other solvents like methylcellulose for water soluble adhesives.
- **Mechanical removal of tape carrier**
 1. Place the document on a clean blotter or work area and weight it down;
 2. Locate the edge of the tape and use the paper knife or scalpel to begin removing it. Keep your cutting tool horizontal to the document and not at an angle. If paper fibers come up with the tape, try moving to a different portion of the tape. If removing the tape will still pull up fibers and cause a loss of information proceed to one of the other techniques described in sections 6-8;
 3. As the tape carrier comes up hold on to it with your free hand and continue making small sawing motions to remove the tape. Do not try to push the tool through.
 4. If the loosened portions of the carrier interfere with removing the rest of the tape, cut these portions off. Remember that if these portions are not cut off, they can re-adhere to the document.

Tape removal cont.

- **Vapor fuming (for synthetic adhesives):** A chemical application to soften or dissolve adhesives. Toluene is usually effective on pressure sensitive adhesives and presents less risk of media solubility. Vapor fuming is a slower process than Fuller's earth method but safer when there are soluble media present.
 1. Place the document on a clean blotter or work area face down and weight down the edges of the document;
 2. Locate the backside of the tape to be removed.
 3. Put a few drops of solvent in the small beaker (50mL) and place this beaker slightly off to the side of the area to be treated;
 4. Cover the small beaker with the larger beaker (500mL) by placing it upside down over the smaller beaker and the area to be treated;
 5. Leave this vapor fuming chamber in place for 15-20 minutes;
 6. Remove the chamber and place it in a fume hood;
 7. Turn the document over and try removing the tape with a paper knife or scalpel;
 8. Stop when the tape becomes difficult to remove and it seems like you will pull up paper fibers;
 9. Cut off the freed carrier;
 10. Turn the document back over and repeat the process as necessary until all of the tape has been removed from the document.

Tape removal cont.

- **Fuller's Earth Method (for synthetic adhesives):** A chemical application to soften or dissolve adhesives. Toluene is usually effective on pressure sensitive adhesives and presents less risk of media solubility. This method is faster than vapor fuming but does directly introduce solvent to the document and any media near the tape.
- 1. Place the document on a clean blotter or work area face down and weight down the edges of the document;
- 2. In a Petri dish mix a small amount of Fuller's earth and solvent with a micro-spatula until you form a dry paste;
- 3. Locate the backside of the tape to be removed and apply a pea sized portion of the paste to this area with the micro-spatula (if it immediately begins to saturate the page the Fuller's earth mixture is too wet);
- 4. Place a glass weight on top of the application followed by a cloth covered weight;
- 5. Check the application every few minutes to see if the Fuller's earth is dry and the toluene has evaporated from it;
- 6. Remove the cloth covered weights and glass;
- 7. Brush off any loose crumbs from the document;
- 8. Turn the document over and try removing the tape with a paper knife or scalpel;
- 9. Stop when the tape becomes difficult to remove and it seems like you will pull up paper fibers;
- 10. Cut off the freed portion of the carrier;
- 11. Turn the document back over and repeat the process as necessary until all of the tape has been removed from the document.

Tape removal cont.

- **Methyl cellulose poultice (for water-soluble adhesives):**
Use a thick consistency methyl cellulose (grape jelly-like)
 1. Apply a thick coating of methyl cellulose to the tape;
 2. Allow it to sit for several minutes;
 3. Carefully remove the tape with a micro-spatula or bone folder;
 4. Repeat steps until tape and adhesive have been removed.
- **Dealing with the adhesive residue or goo:** Methods below are in order of gooeyness of adhesive (gooiest to less gooey)
 1. Apply paper pulp (“pulp” pieces of board in a coffee grinder).
 2. Roll the pulp over the gooey area to pick up the adhesive residue.

Or

1. Use a rubber cement pickup eraser to remove the adhesive residue. Be sure to remove the dirty globules from the eraser as you use it.

Or

1. Use Reemay/Hollytex to wipe off excess adhesive residue.

Or

1. Use a chemical application such as straight toluene or a 4:4:1 mixture of ethanol, acetone and toluene locally using the vapor fuming or Fuller’s earth methods. Remember to test for ink solubility before applying solvents.

Vacuuming

- **Supplies:** HEPA vacuum with variable speeds, soft weights, nylon screen, and blotter
- **Vacuuming through a screen:**
 1. Place the document on a clean blotter or work area;
 2. Place an oversized piece of nylon screen on top of the document and weight the screen down, making sure that the weights are near, but NOT directly on top of the document (Fig. 1);
 3. Start the vacuum on the lowest speed. With a medium sized vacuum head attachment begin vacuuming through the screen;
 5. Continue vacuuming by lifting the vacuum head and reapplying to a new area of the screen. DO NOT move the vacuum head back and forth over the screen.

Set-up for vacuuming through a screen

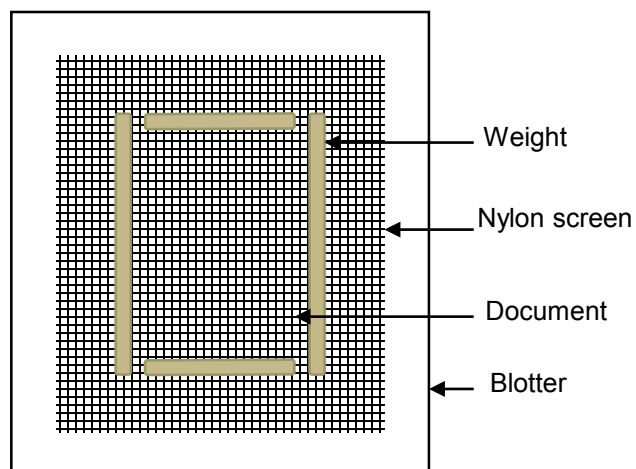

Fig.1

Vacuuming cont.

- **Supplies:** HEPA vacuum with variable speeds, small tool attachments, soft weight, Hake brush and blotter
- **With a brush and small tool attachments:**
 1. Place the document on a clean blotter or work area;
 2. Set-up the HEPA vacuum on low the lowest speed and attach the small tool;
 3. Using a Hake brush, brush the dirt or mold particulates from the center of the document outward toward the vacuum nozzle (Fig.2);
 4. Continue using the brush to move the particulates close to the opening of the small tool attachment.
 5. The vacuum should suck up the particulate **WITHOUT** the small tool attachment **TOUCHING** the surface of the document.

Brushing particulates into a vacuum

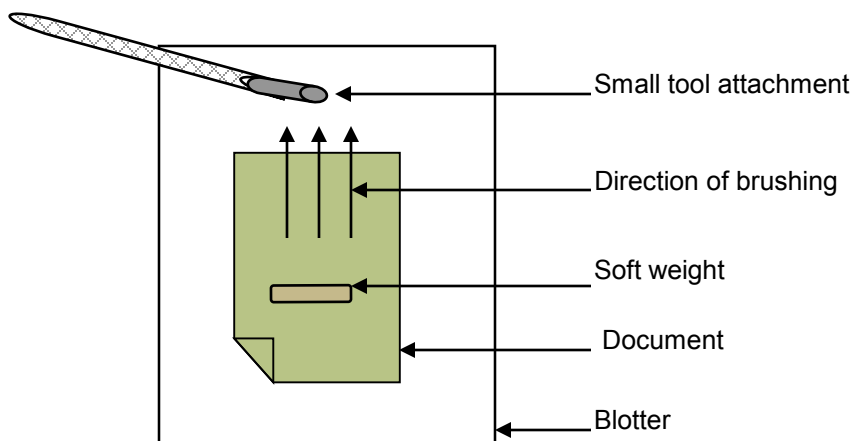

Fig. 2

Dry cleaning

- **Supplies:** clean blotter or workspace, soft weights, dry cleaning sponge, eraser crumbs made by grating white vinyl or plastic erasers (Magic Rub, Staedtler, Pentel) or pre-ground crumbs like Scum X, block erasers of the same variety, and a Hake brush.
- **Basic dry cleaning set-up:**
 1. Place the document on a clean blotter or work area;
 2. Lightly weight down the edges of the dirty document with soft weights;
 3. Hold the page flat with the fingertips of your free hand.
- **With a dry cleaning sponge:**
 1. Using the dry cleaning sponge, gently wipe the document beginning in the center of the document and brushing outward off the edges of the page (Fig.3);
 2. For sootier documents, use the dry cleaning sponge by making small circles on the surface of the document over sooty areas;
 3. Brush all remaining residue from the dry cleaning sponge with a soft Hake brush brushing outward.

Direction of brushing with dry cleaning sponge or Hake brush

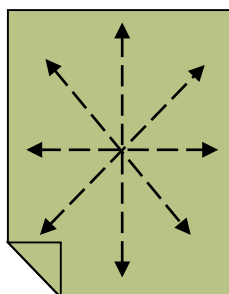

Fig. 3

Dry cleaning cont.

- **With eraser crumbs:** use eraser crumbs to remove dirt from a large surface area on the document
 1. Use basic dry cleaning set-up;
 2. Apply a small amount of eraser crumbs to the center of the document;
 3. Lightly rub the crumbs over the document in small circles with your fingertips (a block eraser, hake brush or cotton ball can also be used in place of fingertips). Move outward from the center of the document and off the edge of the page;
 4. Once the crumbs are dirty brush them off of the document with a Hake brush brushing from the center of the document outward (Fig.3);
 5. Replenish the eraser crumbs with fresh, clean crumbs as needed.
- **With block erasers:**
 1. Use basic dry cleaning set-up;
 2. Use the block eraser for spot removal by locating the dirty spot on the document and making small circles over it with the block eraser. Move outward from the center of the document and off the edge of the page;
 3. Be careful not to apply too much pressure with the block eraser, especially if the document is fragile or brittle;
 4. Use a Hake brush to remove all crumbs (Fig.3).

Washing

- **Washing:** Use washing to remove excess dirt or mud from a document or to help unfold a bundle of documents. Remember to test the solubility of the inks and media used in the document before washing. DO NOT wash moldy documents.
- **Supplies:** clean plastic tray, distilled water, Reemay, Hake brush, and blotters.
 1. Fill the tray $\frac{1}{4}$ to $\frac{1}{2}$ full with distilled water and a sheet of Reemay larger than document. Be careful NOT to overfill the tray;
 2. Place document or bundle in tray and gently push the item down with your fingertips or a Hake brush to fully submerge the item;
 3. Allow the document to soak for a several minutes;
 4. If the document is particularly dirty use a Hake brush to agitate the water and remove the dirt or mud;
 5. Discard the dirty water, replace the water with fresh distilled water, and wash the document again if necessary.

Washing cont.

6. If the documents are folded or bundled together, use a bone or Teflon spatula to unfold them in the water. Be careful not to tear or puncture the paper.
7. Remove each page separately by floating an oversized piece of Reemay under the separated page in the water. Lift the page out of the water and place it onto a piece of blotter. Be sure to keep the Reemay support horizontal or slightly angled while removing it from the water. If it is held vertically the document could fall off of the support.
8. If you cannot insert Reemay under each page, use a sheet of Mylar larger than the document page. Submerge the Mylar over the document, making sure to release air bubbles. Then carefully lift the Mylar with attached page out of the water. Place on top of a piece of Reemay, document side down. By lifting the Reemay, transfer Reemay document and Mylar to a tray with clean water. Remove the Mylar carefully and then lift the Reemay with document out of the tray and place on blotter.

Tear mending

- **Supplies:** archival tape, heat set tissue (like Filmoplast R by Neschen) Reemay, scissors and a tacking iron.
Heat set tissue is a tissue coated with an acrylic resin adhesive that is heat activated. Once applied to a document, it can usually be reversed by applying more heat.
- **Tear Mending with Archival Tape:**
 1. Working on top of a piece of Reemay, align the tear with overlapping edges correctly situated and weight down if necessary;
 2. Cut a piece of archival tape that is slightly longer than the tear. (Cutting the tape in half lengthwise is recommended to minimize visual obstruction caused by tape and to save tape);
 3. Apply the tape by removing the backing and adhering it over the torn area like you would with Scotch tape;
 4. If the tear is not straight, cut the tape into smaller pieces that are the length of each straight section. Apply each of these small pieces of tape to the tear individually until the entire tear has mended covered;
 5. Press tape onto document with bone folder;
 6. Trim excess tape that extends beyond edge of page.

Tear mending

- **Tear mending with heat-set tissue:**
 1. Working on top of a piece of Reemay and blotter, align the tear and weight it down if necessary.
 2. Cut a piece of heat set tissue that is slightly longer than the tear;
 3. Place the tissue over the torn area;
 4. If the tear is not straight, cut the tissue into smaller pieces that are the length of each straight section. Apply each of these small pieces of tissue to the tear individually until the entire tear has been covered;
 5. To adhere the tissue: place tape shiny side down on top of the tear. Then place a piece of Reemay over it and heat the tissue with a tacking iron (Fig.4);
 6. Trim excess tape that extends beyond edge of page.;
 7. Repeat on the reverse side.

Arrangement of layers for adhering heat-set tissue

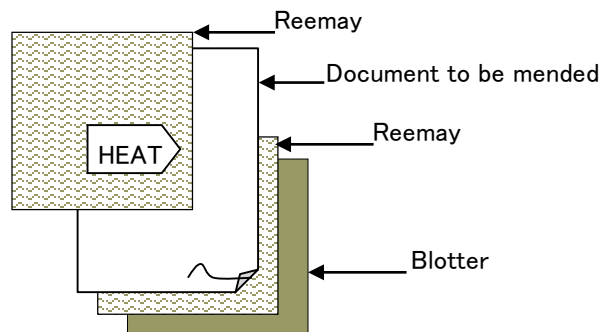

Fig. 4

Backing with tissue

- **Backing with heat-set tissue:**
 1. Place the document face down on a piece of Reemay and blotter;
 2. Cut a piece of tissue that is slightly larger than the document and place it shiny side down on top of the document (Fig. 5);
 3. Put an oversized piece of Reemay on top of the tissue and weight it down;
 4. Use a tacking iron to heat the tissue and adhere it to the back of the document.

Arrangement of layers for adhering heat-set tissue

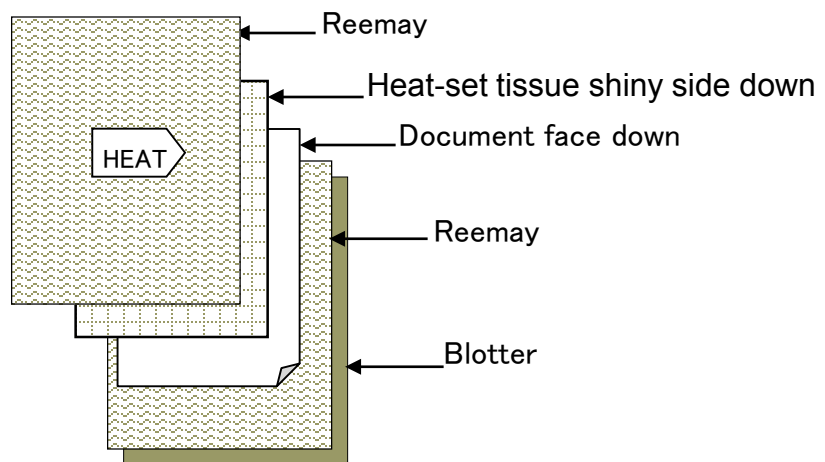

Fig. 5

Backing with tissue

- **Making the backing tissue**
- **Supplies:** methyl cellulose (4.5g MC to 400mL distilled water), silk screen, squeegee, 3 mil Mylar, soft haired brush, Reemay, and thin tissue
- **Creating the tissue with a silk screen:**
 1. Place a sheet of Mylar in the silk screen apparatus;
 2. Place screen on top of Mylar, brush a layer of methylcellulose over screen and then squeegee off any excess;
 3. Remove the coated Mylar and place the coated Mylar on an uncut sheet of thin tissue (make sure the tissue is placed on top of a larger sheet of Reemay to prevent the tissue from sticking to the table);
 4. Smooth out all of the air bubbles and wrinkles;
 5. Continue applying sheets of coated Mylar to the large sheet of thin tissue until completely covered (Fig.6);
 6. Allow tissue to dry then separate the sheets of Mylar;
 7. Use it for backing.

Coated Mylar adhered to sheet of thin tissue

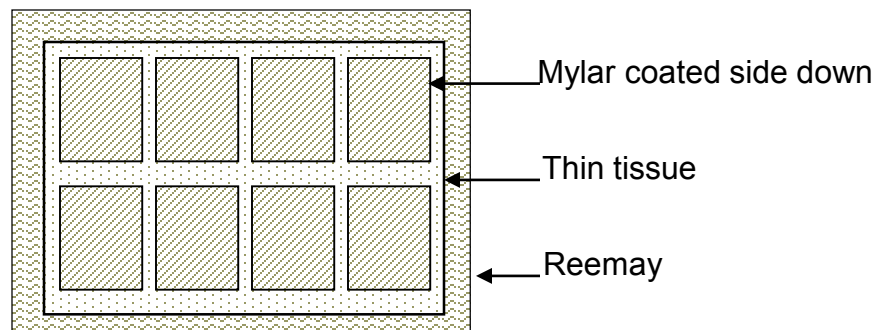

Fig. 6

Backing with tissue cont.

- **Making the backing tissue**
- **Supplies:** methyl cellulose (4.5g MC to 400mL distilled water), silk screen, squeegee, 3 mil Mylar, soft haired brush, Reemay, and thin tissue
- **Creating the tissue with two sheets of Mylar:**
 1. Pre-cut thin tissue to be slightly larger than the Mylar;
 2. Using a Hake brush, brush on a layer of methyl cellulose onto a sheet of Mylar(a);
 3. Place a second sheet of Mylar(b) on top of the coated piece;
 4. Smooth out any air bubbles then slowly pull the sheets apart (Fig. 7);
 5. Place pre-cut tissue on coated Mylar(b) sheet (Fig.8);
 6. Smooth out all of the air bubbles and wrinkles;
 7. Allow it to dry.
 8. Without recoating Mylar(a), repeat steps 3-7 until methyl cellulose layer is too uneven or thin to deposit on Mylar(b);
 9. Continue making backing tissue as needed.

Place Mylar(a) & (b) together and then slowly peel apart

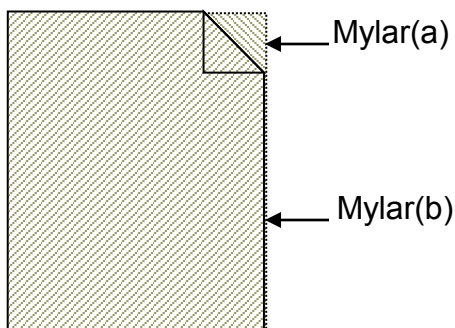

Fig. 7

Smooth tissue onto Mylar from center outward

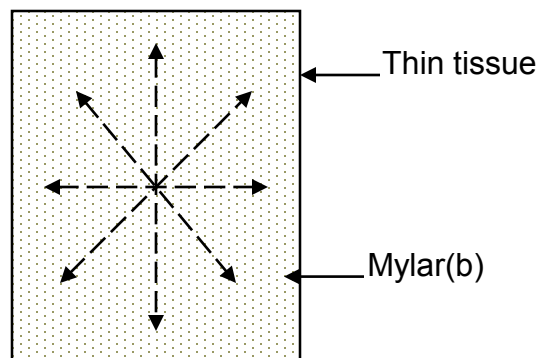

Fig. 8

Backing with tissue cont.

- **Backing with the tissue:** Line fragile documents with thin tissue to stabilize and still allow for legibility through tissue
- **Supplies:** methyl cellulose (4.0g MC to 200mL distilled water), Hake brush, Reemay, blotter, board and weights
- 1. Apply a thin layer of methyl cellulose with a Hake brush to the tissue-side of the Mylar/tissue backing sheets;
- 2. Place the document on top of the methyl cellulose coated tissue (Fig. 9). The process will be most effective if the document has been humidified immediately prior to backing or at least misted;
- 3. Remove the Mylar support;
- 4. Sandwich the document between layers of Reemay and blotter (Fig. 10);
- 5. Place under a board with weights and allow to dry.
- 6. If the document cannot be flattened, leave between Reemay and blotter to dry.

Backed document

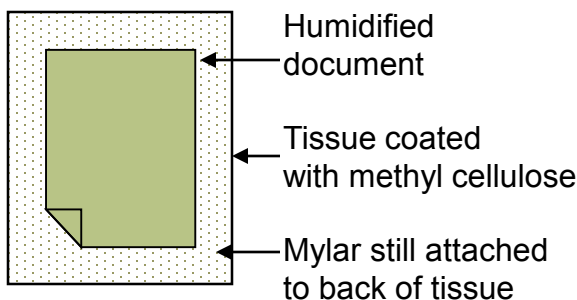

Fig.9

Arrangement of layers for drying backed document

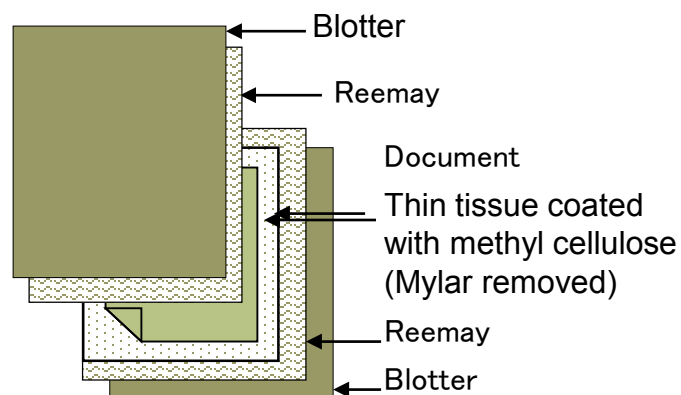

Fig.10

Tape encapsulation

- **Tape encapsulation:** sealing a fragile document between two sheets of Mylar. Not recommended for cockled, brittle documents (see modified sink mat).
- **Supplies:** Mylar, lint-free “magnetic” cloth, 3M 415 ¼” double-sided tape, scissors, bone folder, scalpel, and micro-spatula
- 1. Select Mylar at least two inches wider and taller than document. Keep Mylar clean by wiping with cloth;
- 2. Place document centered below one sheet of Mylar and place soft weight in the middle (Fig.11);
- 3. Apply double-sided tape to the Mylar following the edges of the document below, leaving at least ¼” between edge of document and the tape and allowing tape ends to overlap at the corners (Fig.11);
- 4. Once tape has been applied along all four sides, remove document and miter the corners by carefully sliding a micro-spatula under both layers of tape and then cut through the tape with a scalpel and remove excess tape (Fig. 12);

Application of double-sided tape with ends overlapping

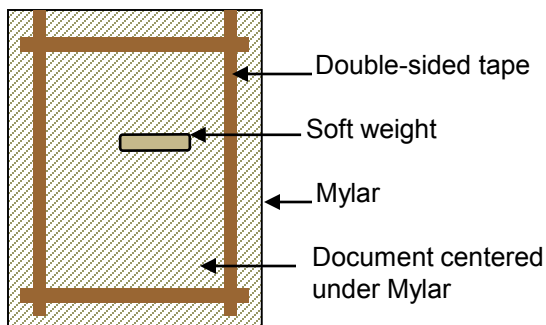

Fig. 11

Miter corners and remove excess tape

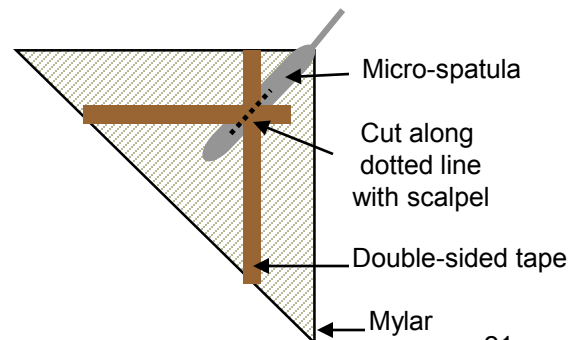

Fig. 12

Tape encapsulation cont.

5. Position document within tape borders and align second sheet of Mylar over taped Mylar and document. Secure with soft weights;
6. Carefully remove backing off of ONE piece of tape and press Mylar in place with fingertips moving from the center out toward the ends of the tape (Fig.13);
7. Moving around the document, continue to remove the backing off of one piece of tape at a time and press Mylar in place.
8. For the final side, carefully pull back the backing without completely removing it. Push the air out between the sheets of Mylar and slowly peel back the backing and press the Mylar in place until the backing is completely removed;
9. Round the corners (Fig.14).

Remove one side of tape backing at a time and adhere Mylar

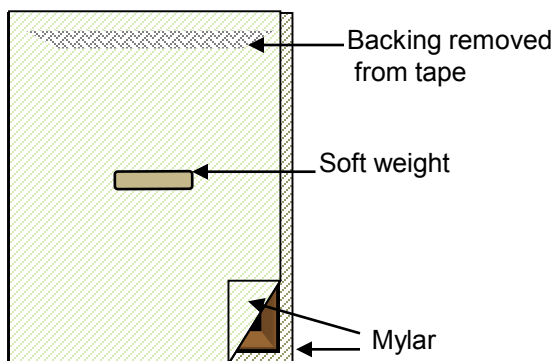

Fig. 13

Completed tape encapsulation with rounded corners

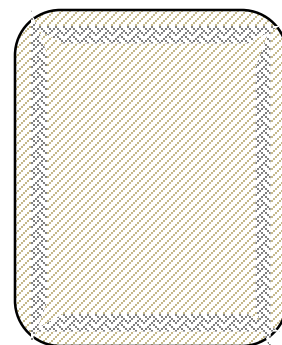

Fig. 14

Modified sink mat

- **Modified sink mat:** protective enclosure designed to accommodate the thickness of a fragile cockled document that cannot be flattened.
 - **Supplies:** Mat material (such as archival foam core, museum mat board, Coroplast), 3M 415 ¼ in. double-sided tape, 5-8 mil Mylar sheets (2), bone folder, ruler, pencil, utility knife
1. Carefully measure the widest (Y) and tallest (Z) points of the document (Fig.15);
 2. Cut TWO pieces of Mylar that measure Y+1" x Z+1" (Fig. 16);
 3. Select the mat that best accommodates that thickness (X) of the document (Fig. 17). (Hint: some pressure on the cockled document will provide some flattening and a more stable condition for the document);
 4. Cut the mat to Y+3" x Z+3";

Document

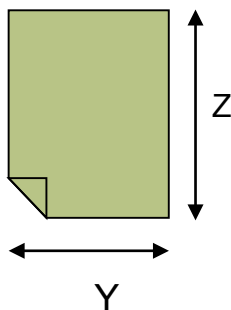

Fig. 15

Mylar

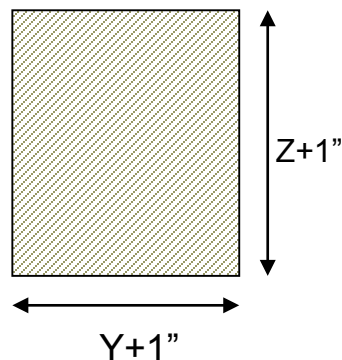

Fig. 16

Document thickness



Fig. 17

Modified sink mat cont.

5. Mark the perimeter for the window opening ($Y + \frac{1}{4}$ " x $Z + \frac{1}{4}$ " in the center of the mat (Fig.18). Using these marks, cut the window opening;
6. Place double-sided tape on the mat along the edges of the window, leaving $\frac{1}{8}$ " gap between the edge of the window opening and the edge of the tape to allow for any adhesive migration over time (Fig.19). Run a bone folder over the tape to secure and miter the corner;
7. Remove the wax backing off of ONE side. Align one piece of Mylar over the window and tape being careful not to let the Mylar adhere to the exposed tape (Fig.20). Once aligned, press in place with your fingers, starting in the middle of the tape and moving out to the ends;

Mat with cutting guides

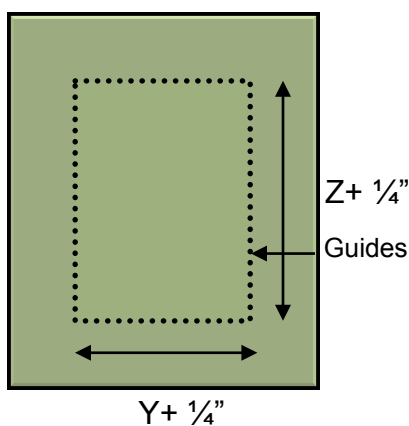

Fig. 18

Mat with window opening cut out

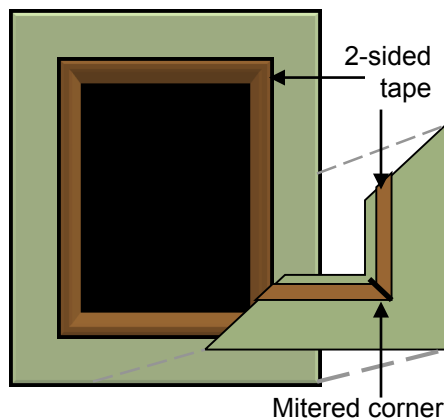

Fig. 19

Mat with Mylar attached on one side

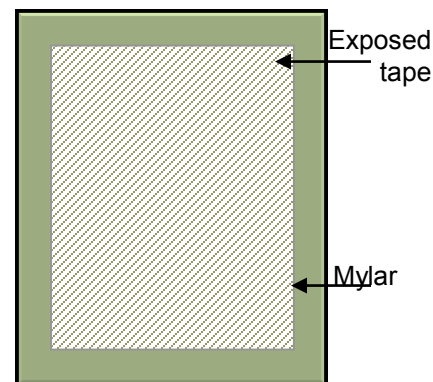

Fig. 20

Modified sink mat cont.

8. Remove the wax backing off of the OPPOSITE side without letting the Mylar come in contact with the exposed tape. Grasp the end of the Mylar with both hands and, pulling taught, place the end of the Mylar on the exposed tape. Press the Mylar in place with your fingers, starting in the middle of the tape and moving outward to the ends (Fig.21);
9. Select one of the un-adhered sides and with one gently lift the edge of the Mylar. With the other hand remove the wax backing off of the tape below. Press the Mylar in place with your fingers, starting in the middle of the tape and moving outward to the ends;
10. Repeat step NINE on the final side;
11. Turn mat over to expose the other side and repeat steps SIX and SEVEN;
12. Carefully place document in the “sink”;
13. Repeat steps EIGHT thru TEN (Fig.22).

Mylar attached on opposing sides
of window opening

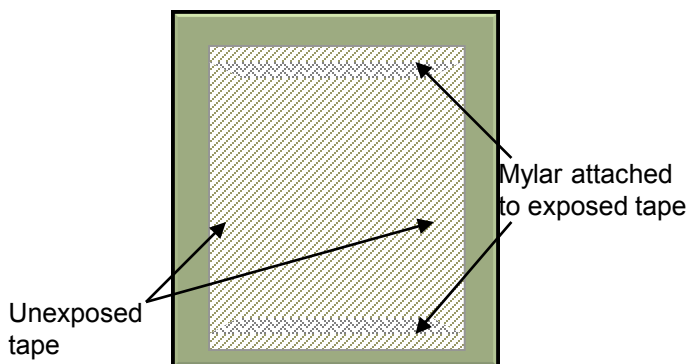

Fig. 21

Completed sink mat
with document encased

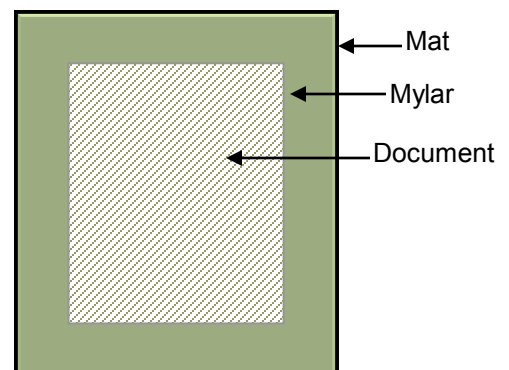

Fig. 22