

9-1977

# Methods for Detecting Moisture Degradation in Graphite-Epoxy Composites

David H. Kaelble  
*Rockwell International*

Follow this and additional works at: [http://lib.dr.iastate.edu/cnde\\_yellowjackets\\_1976](http://lib.dr.iastate.edu/cnde_yellowjackets_1976)



Part of the [Materials Science and Engineering Commons](#), and the [Structures and Materials Commons](#)

---

## Recommended Citation

Kaelble, David H., "Methods for Detecting Moisture Degradation in Graphite-Epoxy Composites" (1977). *Proceedings of the ARPA/AFML Review of Progress in Quantitative NDE, July 1975–September 1976*. 10.  
[http://lib.dr.iastate.edu/cnde\\_yellowjackets\\_1976/10](http://lib.dr.iastate.edu/cnde_yellowjackets_1976/10)

This 3. Adhesives and Composites is brought to you for free and open access by the Interdisciplinary Program for Quantitative Flaw Definition Annual Reports at Iowa State University Digital Repository. It has been accepted for inclusion in Proceedings of the ARPA/AFML Review of Progress in Quantitative NDE, July 1975–September 1976 by an authorized administrator of Iowa State University Digital Repository. For more information, please contact [digirep@iastate.edu](mailto:digirep@iastate.edu).

---

# Methods for Detecting Moisture Degradation in Graphite-Epoxy Composites

## **Abstract**

This presentation reports on the second year of our participation in this NDE program. The purpose of this work is two-fold and this talk divides itself naturally into two segments which relate to the following objectives:

1. To determine the effects of moisture degradation on the mechanical properties of a graphite- epoxy composite under study for use on B-1.
2. To apply promising techniques found in last year's program to detect moisture degradation nondestructively.

## **Keywords**

nondestructive testing, nondestructive evaluation

## **Disciplines**

Materials Science and Engineering | Structures and Materials

METHODS FOR DETECTING MOISTURE DEGRADATION  
IN GRAPHITE-EPOXY COMPOSITES

D. H. Kaelble  
Science Center, Rockwell International  
Thousand Oaks, California 91360

This presentation reports on the second year of our participation in this NDE program (Ref. 1). The purpose of this work is two-fold and this talk divides itself naturally into two segments which relate to the following objectives:

1) To determine the effects of moisture degradation on the mechanical properties of a graphite-epoxy composite under study for use on B-1.

2) To apply promising techniques found in last year's program to detect moisture degradation nondestructively.

The uniaxial reinforced composite chosen for study is described by constituents, lay up, and cure cycle in Table I and represents a standard 350°F (177°C) service ceiling composite. Following cure and post cure as described in Table I, this composite was maintained in a dry state by storage over anhydrous K<sub>2</sub>SO<sub>4</sub> until initiation of moisture degradation studies.

TABLE I. Fabrication and Curing Cycles for Hercules 3501/AS-5 Epoxy Matrix/Uniaxial Graphite Fiber Reinforced Composite SC4 (Volume fraction fiber V<sub>f</sub>=0.60, Void Volume fraction V<sub>v</sub><0.01)

A. Layup Procedure

Ply Number	Tape Width (cm)
1	30.5 + 15.3
2	15.3 + 30.5
3	7.6 + 30.5 + 7.6
4	22.9 + 22.9
5-48	repeat patterns for 1-4

B. Cure Cycle

Step No.	Procedure
1	Bleeder cloth in 3 plies 120 GL plus 14 plies 181 GL and vacuum bag.
2	Vacuum on part plus 5.98 Kg/cm <sup>2</sup> external pressure to bag during heat up from 23°C to 177°C (heating rate 1.1 to 1.7°C/min with 15 min. dwell at 121°C).
3	Dwell at 177 ± 5°C for 1 hour then lower temperature to 23°C
4	Cool down under pressure and vacuum to below 65°C before removing pad.
5	Debag and oven post cure for 3 hours at 188°C.

The experiments used for study of moisture degradation (Part 1) and nondestructive detection (Part 2) are summarized in Table II. In Part 1, the study of moisture degradation interposed

measurements of the kinetics of water up-take, interlaminar shear strength, and failure surface analysis. This study was somewhat simplified from last year, based upon a more complete knowledge of the potential degradation mechanisms.

TABLE II. Experimental Methods for Study of Moisture Effects

Part 1: Moisture Degradation

Moisture take up  
Interlaminar shear strength  
SEM failure surface

Part 2: Nondestructive Detection

Infrared spectroscopy  
Dynamic mechanical spectroscopy (3.5-110 Hz)  
Specific heat  
Ultrasonics (2.25 MHz)  
NMR pulse relaxation spectroscopy  
Microwave spectroscopy  
Micro Hardness

The curves of Fig. 1 show that simple Fickian diffusion kinetics operates. The fraction of maximum moisture,  $\phi$  (H<sub>2</sub>O), is proportional to the square root of exposure time  $t^{1/2}$  at both 23° and 100° C under water immersion. Independent study of the pure matrix showed similar Fickian controlled diffusion mechanisms as shown in Fig. 1 for the composite.

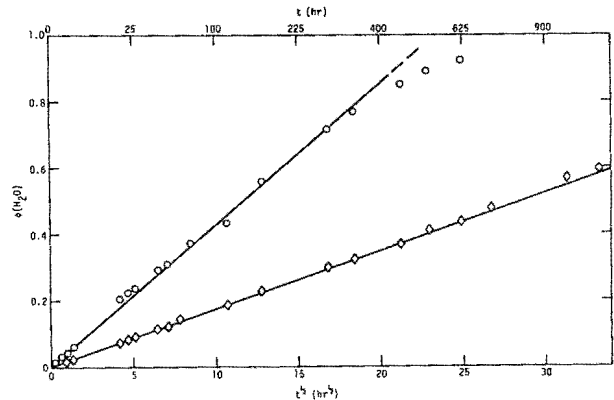

Figure 1. Fractional amount  $\phi$  of water uptake versus exposure time  $t$  for composite SC4 (O=100° C,  $\diamond$  = 23° C).

The numeric analysis of water up-take studies in both composite and pure epoxy matrix are summarized in Table III. Inspection of Table III shows the equilibrium moisture uptake  $f_{\infty}(H_2O)$  is constant for 23°C and 100°C. Table III shows that the moisture uptake in the pure matrix and the matrix phase of the composite agree within 10%. The data of Table III also indicate substantial equivalence for diffusion coefficients  $D$  and activation energies of diffusion  $E_0$  for composite and pure matrix. These results show that the bulk diffusion through the matrix is the rate limiting step and that the moisture resides in the matrix phase of the graphite-epoxy composite of this study. The fact that the matrix phase of the composite will absorb up to 6.7 wt. % of water at 23°C when the composite weight increase is 2.3% suggests substantial changes in internal stresses and mechanical responses.

TABLE III. Water diffusion kinetics for composite SR4 and cured epoxy 3501 matrix

Parameter	SC4 composite ( $V_f = 0.60$ uniaxial)		Pure Matrix		
	$L_1 \times L_2 \times L_3$ (cm)	$0.50 \times 1.50 \times 1.50$	$0.50 \times 1.50 \times 1.50$	$0.22 \times 1.50 \times 1.50$	$0.22 \times 1.62 \times 1.52$
$m_0$ (gm)	1.77643	1.76205	0.65767	0.65931	
$T$ (°C)	23	100	23	100	
$f_{\infty}(H_2O)$ wt%	2.30	2.30	6.70	6.70	
$D$ (cm <sup>2</sup> /sec.)	$7.67 \cdot 10^{-10}$	$2.58 \cdot 10^{-8}$	$8.65 \cdot 10^{-10}$	$6.42 \cdot 10^{-8}$	
$E_0$ (kcal/mol)	10.0		12.2		

Interesting additional information was generated by SEM studies of sectioned composites and of the failure surfaces from interlaminar shear testing. Two notable types of manufacturing defects, as shown in Fig. 2, were found in sectioned composite. The long needle-like defect in the left view of Fig. 2 appears related to fiber misalignment in the prepreg tape. The elliptically shaped cavity shown in the right view of Fig. 2 appears related to deficiencies in interply bonding. Both types of defects, as indicated by the 10  $\mu$ m bench marks, are of large dimensions relative to the fiber diameter. Further studies showed that these large defects were sparsely distributed in the composite and the overall void content is less than 1% by volume.

The combined effects of matrix controlled diffusion kinetics and the noted distribution of large defects and cavities is displayed in the interlaminar shear strength data shown in Fig. 3. The degradation in average shear strength  $\lambda_b$  appears to decrease linearly with increased moisture content at both 23°C and 100°C aging conditions. The effect of 100°C aging is to accelerate the rate of moisture uptake by a factor of 23.

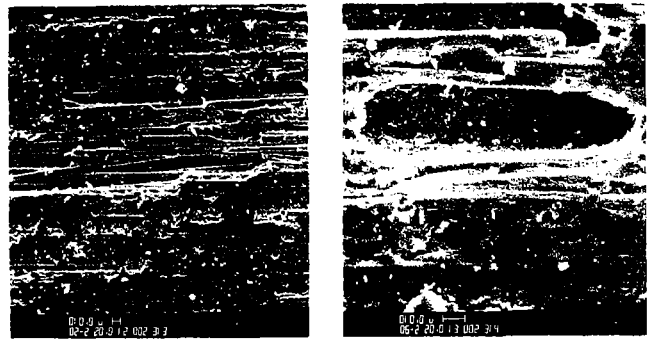

Figure 2. SEM view of external cut surface of shear test specimen ( $\lambda_b = 920$  Kg/cm<sup>2</sup>) for dry unaged SC4 composite showing two types of macroscopic defects (size larger than 10  $\mu$ m).

The large scatter of interlaminar shear data in Fig. 3 are indicated by the vertical bars which enclose the extreme high and low values of  $\lambda_b$  based on five or more tests at each test condition. This large data scatter is a striking feature of the composite response which appears related to the manufacturing defects shown by SEM studies. The dry unaged composite has a mean shear strength  $\lambda_b = 779$  kg/cm<sup>2</sup> ( $\approx 11000$  psi) with extreme high and low values of 1000 kg/cm<sup>2</sup> (14000 psi) and 528 kg/cm<sup>2</sup> (7500 psi) in a group of 20 test specimens. The mean strength degradation of 22% in  $\lambda_b$  shown by the linear least square fit curve of Fig. 3 is clearly overshadowed by the data scatter.

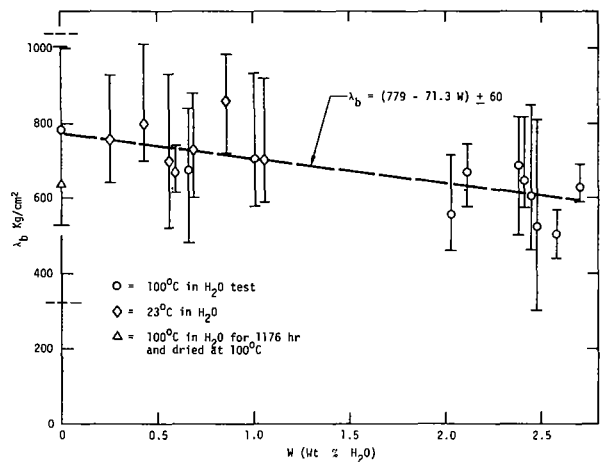

Figure 3. Variation in interlaminar shear strength  $\lambda_b$  with moisture content (Wt % H<sub>2</sub>O) in composite SC4. Bars on data points indicate extreme  $\lambda_b$  values for test group.

The results of analysis of three test conditions using the Weibull (or extreme value method is shown in the curves of Fig. 4. The ordinate of Fig. 4 is a linear scale of survival probability

(Ref. 2):

$$S = 1 - \frac{j-0.50}{N}$$

where the test results are arranged serially  $j = 1, 2, 3, \dots, N$  in increasing order of  $\lambda_b$  and  $N$  is the number of test specimens. The solid curves in Fig. 4 are fit to the experimental data by use of the relation (Ref. 2):

$$S = \exp(-\lambda/\lambda_0)^m$$

where  $\lambda_0$  is the mode of the distribution, and  $m$  defines the breadth of the distribution. The right curve of Fig. 4 for unaged composite displays  $\lambda_0 = 837 \text{ kg/cm}^2$  and  $m = 7.6$ . Both the aged - wet and aged-dried data fall on a second curve with  $\lambda_0 = 636 \text{ kg/cm}^2$  and  $m = 3.9$ . These results indicate that the effects of moisture aging are not reversed by subsequent removal of water for this composite. Secondly, the significant lowering of the Weibull shape factor  $m$  due to moisture aging shows an appreciable strength degradation of 50% at high survival probability of  $S = 0.95$ .

A simple physical interpretation of the data of Fig. 4 suggests that samples with larger internal defects and therefore lower intrinsic strength are more severely damaged by hydrothermal aging than samples of higher intrinsic strength. For the aged and dried material, only a few data points representing samples with small defects indicate the possibility of strength recovery after aging. These latter samples appear to suggest that a composite intrinsically free of large defects should show a larger degree of reversibility in moisture damage effects. These are early results; further study of these interesting results are required.

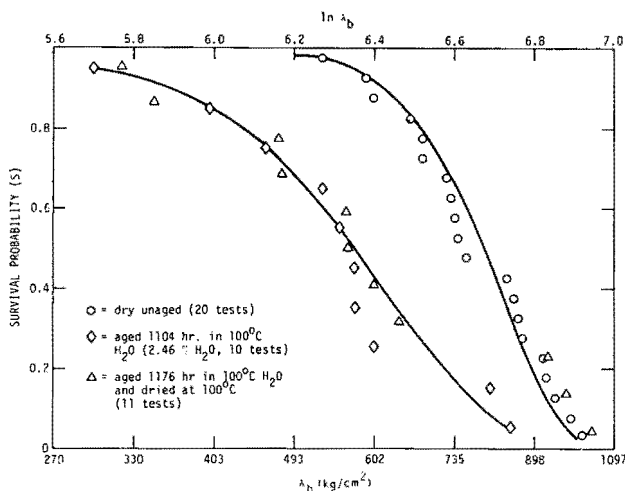

Figure 4. Probability of survival ( $S$ ) versus interlaminar shear strength  $\lambda_b$  measured at  $23^\circ\text{C}$ .

The nondestructive characterization which constitutes part II of this study utilized infrared spectroscopy, NMR, and other techniques that are very familiar to the analytical chemist. From this characterization, one obtains the chemical composition of the uncured material and chemical structure of the cross-linked epoxy matrix. The results of this study, shown in Table IV, show that the tetrafunctional epoxy is cured by diaminodiphenyl sulfone (DDS) to produce the cross-link network shown in the chemical structure in the lower portion of Table IV. This chemical structure is indicative of a higher glass temperature  $T_g$  and more brittle epoxy than the epoxy matrix studied in the previous year. In particular, this resin system does not contain the flexible glycidyl ether segment which characterized the  $250^\circ\text{F}$  ( $122^\circ\text{C}$ ) service ceiling epoxy matrix of last year.

These differences in chemical structure between the two resin systems studied last year and this year appear very clearly in the mechanical spectroscopy response, using thermal scans of dynamic mechanical damping at fixed frequency of 110 Hz on the Rheovibron instrument. The test specimen is a thin axially reinforced cylinder of composite subject to cyclic flexure deformation.

TABLE IV. Suggested Curing Mechanism for Epoxy 3501 Resin

Epoxy (E): tetraglycidyl 4,4' diaminodiphenyl methane:  
M.W. = 422 gm/mole

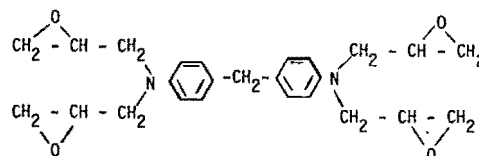

Curative (C): diaminodiphenylsulfone; M.W. = 251.5 gm/mole

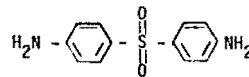

Crosslink Reaction (62.7% by weight E + 37.3% by weight C)

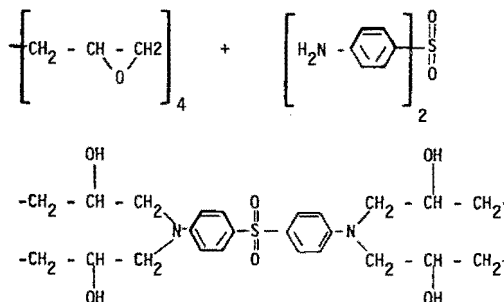

As shown in Fig. 5, the curve of loss tangent ( $\tan \delta$ ) versus temperature for the unaged composite shows no detectable damping maximum below 200°C indicative of the lack of segment motion as revealed by chemical analysis. Above 200°C the rise in  $\tan \delta$  to a maximum at 260°C is characteristic of the glass transition  $T_g$  and onset of rubbery response of the epoxy matrix.

Testing this same material aged and wet is shown as a second curve in Fig. 5 where  $\tan \delta$  values begin to increase at  $T = 130^\circ\text{C}$ . Water is lost as heating progresses so that this second curve represents a wet sample at low temperature  $T \leq 100^\circ\text{C}$  and dried during measurement at  $T \geq 250^\circ\text{C}$ . A third thermal scan shows that the  $\tan \delta$  curve for aged and dried composite generally resembles the unaged material. These data show the water reversibly plasticizes high temperature molecular motions above  $130^\circ\text{C}$  but has little effect upon  $23^\circ\text{C}$  rheological properties.

The expectation from chemical analysis and mechanical spectroscopy was that ultrasonic properties such as sound velocity and matrix attenuation in the composite of this year's should be only slightly affected by moisture. In contrast the  $250^\circ\text{F}$  composite of last year's study showed substantial changes in ultrasonic response with moisture uptake at ambient  $23^\circ\text{C}$  test temperatures.

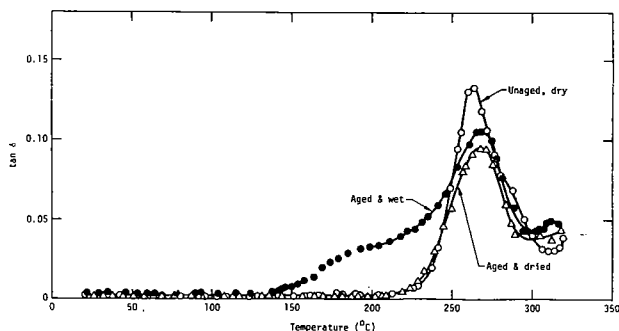

Figure 5. Flexural damping  $\tan \delta$  properties of composite SC4 measured by increasing temperature scans at  $f = 110 \text{ Hz}$

Based upon this knowledge we designed a hybrid experiment. We machined a bar of composite of shape  $L \times W \times T = 30 \times 2.5 \times 0.5 \text{ cm}$  dimensions with fibers parallel to the length. This bar looks like a ruler which is very black and very opaque. The moisture aging produced four zones of hydrothermal exposure which are boiling water, water vapor at  $100^\circ\text{C}$ , seal area, ambient  $23^\circ\text{C}$ , and 50% RH exposure along the length of the bar. This aging was carried on for 1128 hr. to fully hydrate the 6.3 cm (2.5 in) length immersed in boiling water.

This sample was then removed and ultrasonically scanned along its length using 2.25 MHz and  $23^\circ\text{C}$  as test conditions and C-scan through the sample thickness. Details of the method follow methods discussed in the first year effort. This procedure profiles in one dimension the influence of variable hydrothermal aging on ultrasonic response.

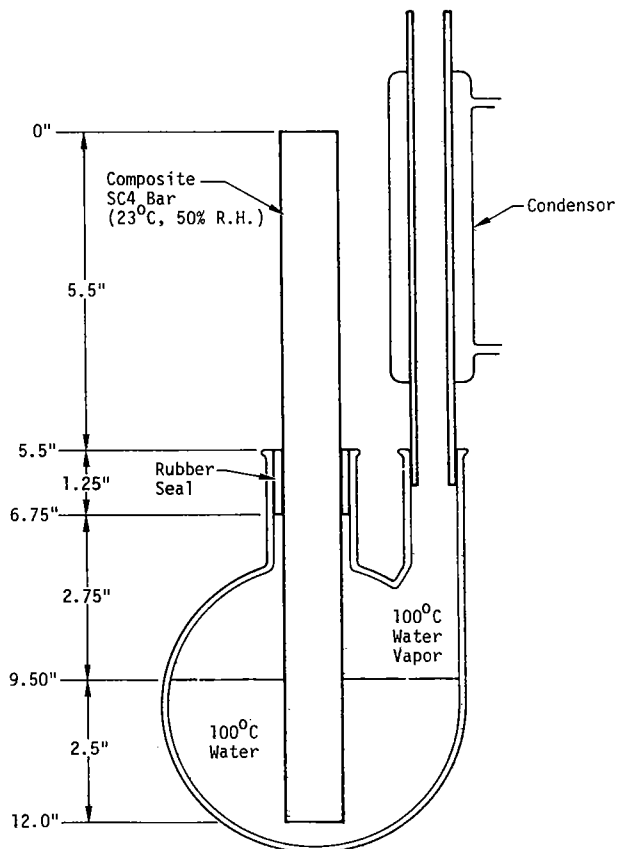

Figure 6. Schematic of variable moisture exposure of composite SR4 aged for 1128 hours.

The lower curves of Fig. 7 show that spatial attenuation  $\alpha_L$  does not vary with moisture aging or moisture content along the bar length. The lower curve of Fig. 8 shows that sound velocity  $C_L$  is dependent upon prior moisture aging and moisture content along the bar length.

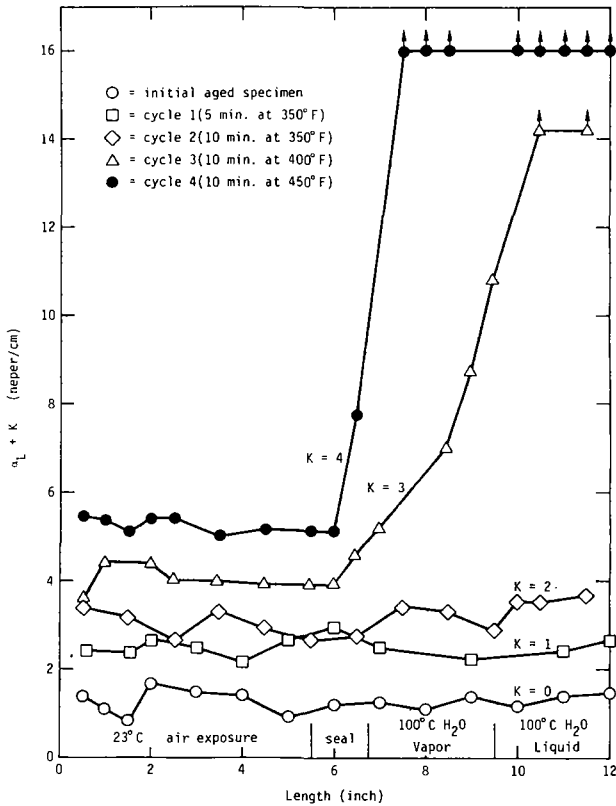

Figure 7. Effects of varied moisture exposure and subsequent thermal cycles on the acoustic attenuation  $\alpha_L$  of composite SC4.

Having established the base line shown by the lowest curves of Figs. 7 and 8 the bar was then subjected to a series of thermal shock cycles between 23°C and the ceiling temperature shown in upper Fig. 7. Cycle 1 and Cycle 2 (to the 350°F service ceiling recommended for this composite) show only minor effects on either  $\alpha_L$  or  $C_L$ . These curves are vertically shifted by the indicated factors K along the ordinate to provide separation of the curves. A subsequent thermal shock cycle to 400°F produces a large increase in  $\alpha_L$  in the length exposed to high moisture and unchanged  $\alpha_L$  in the ambient aged low moisture section. A final cycle to 450°F effectively raises  $\alpha_L$  out of the region of available measurement in the high moisture exposed region and shows  $\alpha_L$  unchanged for the ambient aged section.

Inspection of Fig. 8 shows that the sound velocity change along the bar length decreases slightly with thermal shock cycling due to thermal cycling. Thermal cycles 3 and 4 which produce the high attenuation lead to signal loss and prevent velocity measurements on the hydrated end of the bar.

In the above measurement it appears that velocity profiles as shown in Fig. 8 correlate with moisture content. Sound velocity transverse to the fibers is matrix dominated. With increasing moisture content the lower sound velocity of water  $C_L = 1.49$  km/s operates through the rule of mixtures to lower the average sound velocity from  $C_L = 3.6$  km/s for the dry composite.

In addition to the above acoustic measurements, accurate measures of thickness confirm the opening of microcracks in the high moisture length by a relative thickening or dilation of this damaged section.

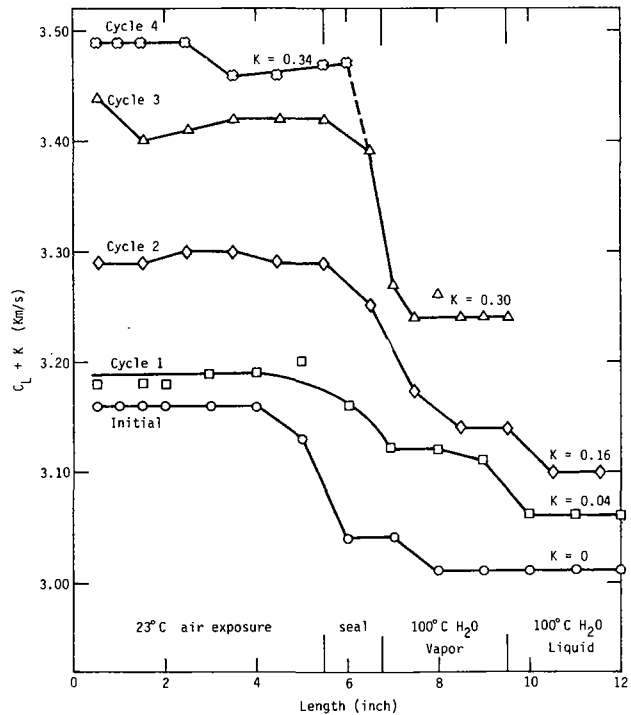

Figure 8. Effects of varied moisture exposure and subsequent thermal cycles on the ultrasonic velocity  $C_L$  of composite SC4.

As a result of both the work reported for this year and the previously reported study of last year, we have developed a systematic outline for composite durability and NDE analysis as detailed in Table V. This outline calls for first analyzing the composite in terms of its separated components. This physiochemical study of the fiber and matrix constituents isolates their discrete interactions to moisture and temperature.

In this outline of study the fiber-matrix interface stands out as an independent subject of study in terms of surface energetics.

The composite is evaluated in terms of system response with a large variety of relevant measuring tools and interacting information.

Finally, in Part 3 of Table 5 is outlined a data analysis task to correlate constituents,

TABLE V. Outline for Composite Durability Characterization

Part 1:	Analysis of Separated Fiber and Matrix
	1a. Obtain and separate uncured prepreg components, 1b. Analyze fiber and matrix surface energies, 1c. Analyze resin chemistry and curing mechanism, 1d. Define curing kinetics and network structure, 1e. Analyze hydrothermal aging effects on network structure.
Part 2:	Analysis of Composite Laminate Aging
	2a. Obtain composite laminates for aging studies, 2b. Measure kinetics of water diffusion into composite, 2c. Determine interlaminar shear strength versus moisture content, 2d. Determine fracture energy versus moisture content, 2e. Measure dynamic mechanical (NDT) response versus moisture content.
Part 3:	Data Analysis and NDT Methodology
	3a. Determine relation between strength degradation mechanisms and NDT methodology, 3b. Design NDT experiments and statistical analysis for tracking strength degradation, 3c. Define improved matrix and interface chemistries.

interface, and system responses in terms of analytic models. Quantitative NDE tracking methodology and statistical analysis of data are resultant from this approach. A final dividend is that enough detailed chemical information is developed to intelligently pursue material substitutions or changes in interfaces by surface treatments.

In brief, then, the conclusions that come from this phase of work are as follows for Part I.

1. In the 3501-5/type AS composite the kinetics of moisture degradation are controlled by the matrix bulk properties.
2. The interlaminar shear strength degradation is irreversible and the Weibull analysis shows that degradation is greatest in samples with larger intrinsic flaws.

In Part II for NDE response the following conclusions appear justified.

1. In the 3501-5/type AS composite ultrasonic sound velocity at 23°C varies with moisture content but not with strength.
2. Alternatively, attenuation transverse to the fiber axis is principally sensitive to internal defects and microcracks which influence matrix and interface dominated measures of strength.

These results differ from the composite system studied last year where both sound velocity and attenuation changed complimentary with strength and were related by chemical changes in matrix rheology and molecular motion.

This year's study in conjunction with last year's shows that each resin type can be expected to display a singular physio-chemical response to moisture and require a specific NDE tracking methodology. Consistent with this result for the B-1 composite we can now undertake NDE black box development for moisture degradation effects. Two parallel developments appear warranted. We have used a number of NDE tools including NMR and microwave dielectric spectroscopy this year in addition to the ordinary measurements but we find that, for field surveillance, precision ultrasonics stand out as a well verified technique. Using ultrasonics to assess changes in physical state response as well as physical flaws is the present extension of this methodology.

The second measurement to be recommended is a direct reading moisture content meter for composites. It appears quite necessary to know the current moisture state of the composite, and if the moisture content can be spatially resolved by mapping all the better. We have plans and activity in progress on this latter subject in which moisture effusion measurements are utilized. By placing a surface cell on the composite and lowering the relative humidity to zero one can accomplish a kinetic analysis of moisture effusion which is the reverse of the moisture uptake analysis discussed earlier in this presentation.

In conclusion, precision ultrasonics combined with direct moisture content analyses appear applicable to field surveillance of B-1 composites studied in this program.

#### References

1. D. H. Kaelble, in Proceedings of the ARPA/AFML Review of Quantitative NDE, AFML TR-75-212, pp 549-562.
2. E. Y. Robinson, in Proc. of Colloquium on Structural Reliability (Editors: J. L. Swedlow, T. A. Cruse, and J. C. Halpin), Carnegie-Mellon University, Pittsburgh (1972), pp 463-526.



## DISCUSSION

- PROF. MAX WILLIAMS (University of Pittsburgh): I can't believe that you have beat the bell. Just, perhaps one question to start our discussion, Dave, to make sure I understand, the wave velocity through the specimens decreased with increased moisture. Do you have a qualitative feeling that that change with moisture is a density effect or a chemical structure effect like backbone binding energy?
- DR. KAELBLE: First of all, the wave velocity in the dry composite is definitely assignable to the matrix. It looks like the matrix is interacting with fibers in a series fashion. The dry matrix sound velocity is  $C_L = 2.92$  km/cm and water is  $C_L = 1.49$  km/s at 23°C and 2.25 MHz. In a rule of mixtures a 7% water uptake would reduce the sound velocity by about 3% as is shown in Figure 6B.
- PROF. WILLIAMS: You know, a simple engineering approach would be that if the wave velocity is proportional to the square root of modulus over the density and if you're adding water, that would increase the density in the denominator which would drop the wave velocity which is consistent with your observation. My question is whether that is entirely too simplified an approach or whether it is actually tied up in the binding energy dropping along the backbone chain.
- DR. KAELBLE: Yes, if water is entering only void and pores, its density would act as you suggest. This effect is taken into account because we do a precise thickness measurement so the water that goes in, actually its volume effect, is taken up in the path length measurement. You see, we do a time delay measurement. Calculations show that density changes accounts for about 20 percent of the velocity change.
- DR. WILLIAMS: Any other questions? Dave, would you call your own questions, please.
- DR. KAELBLE: Bill?
- DR. BILL BASCOM (Naval Research Laboratory): In your damping curve for your NARMCO 5208--were you using the Narco or some other resin?
- DR. KAELBLE: Hercules 3501-5 was the resin used in this study.
- DR. BASCOM: They're essentially the same. You did not get a peak until you got to the glass transition phase for the dry material; is that correct?
- DR. KAELBLE: That's true.
- DR. BASCOM: We see one at about 75° centigrade on supposedly dry material.
- DR. KAELBLE: That's right.
- DR. BASCOM: Is this saying that the specimens are taking up water, or are yours intentionally dry?
- DR. KAELBLE: Yes, ours are dry. They're dry from the point of manufacture. They're held dessicated. We have gotten a lot more careful about that since we came across the fact that the effects, damage effects, are irreversible and if you let these materials sit at room temperature you can have an unknown history of change from point of manufacture. So, we hold these dessicated up until either the time of controlled exposure or time of test. I have seen that transition, and actually, on another scale of sensitivity, even on these curves, it might show up. But I might mention these measurements are made on the composite by transverse bending of longitudinal reinforced.
- DR. JOSEPH HEYMAN (NASA, Langley): Is the temperature dependence of the velocity of sound in the epoxy sufficiently well known so that you could monitor the water content by looking at the temperature dependent change in velocity of water?
- DR. KAELBLE: Yes. We haven't done that. I presume that would be a useful extension on the reported velocity measurements.
- PROF. WILLIAMS: One more question, please.
- DR. PAUL FLYNN (General Dynamics): Did you see any mechanical properties and other possible changes other than strength that were relatable to the velocity of sound? Did you do modulus effect on the property?
- DR. KAELBLE: In this program we limited our measurements to interlaminar shear strength. This built up enough data base to say something significant about a matrix or interface controlled system response property. This same material is being looked at concurrently in an IR&D program where much more extensive results will be reported separately.
- PROF. WILLIAMS: Thank you very much, Dr. Kaelble.