

4-28-2017

Grain Entrapment Rescue Simulator

Marshall Lynch

Iowa State University, mhlynch@iastate.edu

Tavis Phillips

Iowa State University, tavisph@iastate.edu

Bryce Ring

Iowa State University, bring@iastate.edu

Scott Schilb

Iowa State University, scschilb@iastate.edu

Austen Schoof

Iowa State University, aaschoof@iastate.edu

See next page for additional authors

Follow this and additional works at: <https://lib.dr.iastate.edu/tsm416>



Part of the [Bioresource and Agricultural Engineering Commons](#), and the [Industrial Technology Commons](#)

Recommended Citation

Marshall Lynch, Tavis Phillips, Bryce Ring, Scott Schilb, Austen Schoof, Joseph R. Vanstrom and Jacek A. Koziel. Grain Entrapment Rescue Simulator. Final Report. TSM 416 Technology Capstone Project, April 28, 2017.

This Article is brought to you for free and open access by the Undergraduate Theses and Capstone Projects at Iowa State University Digital Repository. It has been accepted for inclusion in TSM 416 Technology Capstone Projects by an authorized administrator of Iowa State University Digital Repository. For more information, please contact digirep@iastate.edu.

Grain Entrapment Rescue Simulator

Problem Statement

Professional Rescue Innovations (PRI) is a small, local, privately owned company that focuses on training rescue personnel for various rescue situations. The focus of this project has been on a grain entrapment rescue simulator. PRI conducts entrapment training sessions nearly every week where they train groups ranging in size from fifteen to twenty people. PRI has outgrown their current simulator. They would like to design and build a new simulator to keep up to date with current training needs. They would like to decrease the time between training exercises as well as enhance several additional simulator features. These features include lowering the overall height of the trailer, installing another bulk bin, and integrating a larger walkway. At the commencement of the project, PRI was uncertain of the extent of funds they wished to commit. Without an established budget, our team elected to conduct a design only project. PRI desired to know the exact cost associated with the purchase of necessary components and fabrication of a new simulator. Our research showed that there are other simulators in existence but in a limited quantity. Since no one company manufactures these simulators and all are unique it is difficult to determine if any other users have faced similar problems. Our client was hesitant in selecting a different design and instead wished only to alter their existing design. However, our team is confident that our modified design could potentially set a standard for other creators.

Disciplines

Bioresource and Agricultural Engineering | Industrial Technology

Authors

Marshall Lynch, Tavis Phillips, Bryce Ring, Scott Schilb, Austen Schoof, Joseph R. Vanstrom, and Jacek A. Koziel

IOWA STATE UNIVERSITY

Department of Agricultural and Biosystems Engineering (ABE)

TSM 416 Technology Capstone Project

Grain Entrapment Rescue Simulator

Marshall Lynch ^a, Tavis Phillips ^b, Bryce Ring ^c, Scott Schilb ^d, Austen Schoof ^e, Joseph R. Vanstrom ^{f*}
and Jacek A. Koziel ^{g*}

^a Agricultural Systems Technology, ABE, ISU, mhlynch@iastate.edu

^b Agricultural Systems Technology, ABE, ISU, tavisp@iastate.edu

^c Agricultural Systems Technology, ABE, ISU, bring@iastate.edu

^d Agricultural Systems Technology, ABE, ISU, scschilb@iastate.edu

^e Agricultural Systems Technology, ABE, ISU, aaschoof@iastate.edu

^f Dept. of Agricultural and Biosystems Engineering, ISU, 2321 Elings Hall, Ames, IA 50011,
vanstrom@iastate.edu, 515-294-9955

^g Dept. of Agricultural and Biosystems Engineering, ISU, 4350 Elings Hall, Ames, IA 50011,
koziel@iastate.edu, 515-294-4206

*course instructors and corresponding authors.

Client: Professional Rescue Innovations, 28495 R. Ave., Adel, Iowa, 50003, (<http://www.prirescue.com/>)

- Contact(s): Jerry Eslick, Owner/President, jerry.eslick@prirescue.com, 515-480-2694

1 PROBLEM STATEMENT

Problem Statement

Professional Rescue Innovations (PRI) is a small, local, privately owned company that focuses on training rescue personnel for various rescue situations. The focus of this project has been on a grain entrapment rescue simulator. PRI conducts entrapment training sessions nearly every week where they train groups ranging in size from fifteen to twenty people. PRI has outgrown their current simulator. They would like to design and build a new simulator to keep up to date with current training needs. They would like to decrease the time between training exercises as well as enhance several additional simulator features. These features include lowering the overall height of the trailer, installing another bulk bin, and integrating a larger walkway. At the commencement of the project, PRI was uncertain of the extent of funds they wished to commit. Without an established budget, our team elected to conduct a design only project. PRI desired to know the exact cost associated with the purchase of necessary components and fabrication of a new simulator. Our research showed that there are other simulators in existence but in a limited quantity. Since no one company manufactures these simulators and all are unique it is difficult to determine if any other users have faced similar problems. Our client was hesitant in selecting a different design and instead wished only to alter their existing design. However, our team is confident that our modified design could potentially set a standard for other creators.

Business Case Statement

PRI has several issues with the current simulator. These include: existing simulator inefficiencies while training large groups, simulator trailer dimension restrictions when attempting to store or train in buildings with limited clearance, lack of training features, as well as general simulator limitations encountered from extensive use over the past seasons. The simulator will require a full redesign due to many constraints such as height, weight, and functionality. Our team will attempt to retain as much of the original design as possible to make operating the new simulator simple and effortless. Our client wished to keep several components the same or similar to the current simulator. These problems occur most often during training large groups and/or training in an environment with limited space. These issues are always present in some quantity. As well, the increased demand for trainings only creates more issues when trying to train clients during winter or spring seasons when weather is not cooperative. It makes sense to address this problem because these issues directly affect the training effectiveness and efficiency. By solving these issues PRI trainers will be better suited for training both larger and smaller groups in a variety of locations. The introduction of an additional simulator will allow PRI to conduct more training sessions and better accommodate their growing clientele. Each member of our team cares deeply about this project and the training PRI currently conducts. This is a very important project because many people are killed each year due to being entrapped in a grain bin. It is crucial that we can design a new simulator that gives PRI the ability to train first responders and farmers of grain bin entrapment so they are more aware and able to aid in a potential rescue.

2 GOAL STATEMENT

PRI has outgrown their current simulator. It is no longer effective and efficient during training exercises. With an increase in business, PRI wishes to introduce an additional, more modern simulator. A new simulator will resolve these issues and allow them to expand and reach more clients. Several factors will be improved with the construction of a new simulator. Most importantly, the time necessary to train clients will be significantly reduced. With the addition of a second bulk bin, along with improved augers and motors, ideally PRI would be able to train twice as fast as before. However, our team has accounted for 80% efficiency. This will allow PRI to train a group in 5 hours, compared to the 8 hours necessary for a current training session. Another benefit with the new simulator is increasing training group size. The simulator would be able to accommodate up to 36 trainees, instead of the previous capacity of 20. With an increase in training capacity, PRI's net revenue would increase almost 30% per client. As a crucial part of the project our team analyzed the new design and sufficiently estimated the increase in training efficiency that our client will experience. This efficiency can be broken down into several key items. These items include reduction in training time, increase in trainee capacity, and increase in profits. All of our calculations were based off a combination of data collected from current client practices and simulator as well as data estimated from our team's new design. To view full fiscal breakdown, see Figure 6 in Appendix B (Section I).

Main Objective(s) and Specific Objectives

In order to solve the aforementioned problems and in order to stay within all constraints laid out by our client our team determined that we would retain as much of the original design as possible. However, our team decided to do so with newer equipment. Our team designed the new simulator to be similar and just as easy to operate as the existing one. The main objective of this project has been to re-design and price a new simulator that will address and solve all of the current problems that PRI faces with the existing simulator. Our client wished to reduce time between simulator exercises to increase training efficiency, redesign simulator platform to include two bulk bins, larger walkway, additional storage, and incorporate optional training features. Our client also desired that the simulator platform must be positioned on tandem axel car trailer with conventional bumper hitch. Project constraints included ensuring that the simulator design dimensions must be less than ten feet tall including trailer height, that the simulator must include similar or greater storage capacity, simulator platform and construction must meet OSHA and DOT standards and all electrical components must be easily operated and powered by a standard 120-volt outlet. To view full list of project objectives and constraints, see Appendix B (Section II).

Rationale

When the current problems are resolved, our client will be able to more effectively and efficiently train both large and small groups in a variety of locations. As well, with two simulators our client will be able to conduct more training sessions for customers. This will allow our PRI to both greater meet client needs as well as expand their current business. By redesigning the simulator to encompass the project objectives our team will make training exercises run smoother and quicker.

3 PROJECT PLAN/OUTLINE

Methods/Approach:

While designing the new simulator, our team ensured that trainer/trainee safety was a top priority. In order to do so, our team referenced a multitude of government and third party regulations to ensure that all parts of the simulator would be safe, function properly, and last for years to come. To view full list of reference materials and how they were used, see Appendix C (Section I). During the process of the project our team used a multitude of sources to determine product/material details. To view full list of product and material information, see Figure 7 and additional information in Appendix C (Section II). Our team used online material, local businesses, and university faculty as key resources in determining and ensuring that our suggestions would indeed solve the problems faced in the most efficient manner. The skills that our team used during the project included general teamwork skills such as communication, dedications, and hard work among others. The project also required several technical skills such as a general knowledge and understanding of agricultural equipment, construction, fabrication, and welding. As well, software skills such as an understanding of AutoCAD and SolidWorks were key during the designing process. Our team believes that our experience in many past courses aided us during this project. These courses included TSM 363 for the knowledge and understanding of how to properly size, install, and wire the necessary electric motors and controls and TSM 216 for the knowledge and ability

to use Autodesk Inventor software with confidence in order to properly create a design and rendering. To view full list of courses, see Appendix C (Section III).

While creating, the new simulator design our team worked closely with university faculty, local businesses and our client to determine the best possible and most feasible solutions to constraints. Our team used project objectives as a cornerstone in evaluating possible solutions to ensure that each possible solution properly resolved the problem. Our team also ensured that any possible solutions did not interfere with project scope. We understood that PRI has committed a limited amount of resources so we do not want a solution that will require a large time or financial commitment, which would expand the project scope in a negative way. To view our team's full list of solutions please view the appendix (Appendix5). In order to ensure our project was organized our team set a goal of bi-weekly communication with our client. Our team also met at least twice a week to ensure all weekly goals were met in a timely manner. This helped to ensure that our team met all necessary project milestones.

Results/Deliverables

Our team's project deliverables include a detailed design blueprints of the new simulator, CAD software rendering, required material list and complete purchasing quote. These deliverables are consistent with the project objectives and scope. These deliverables give our client the knowledge and understanding of everything associated with building a new simulator. To view full list of deliverables, see Appendix C (Section IV).

4 BROADER OPPORTUNITY STATEMENT

Our project is very straightforward and can be understood by any observer. With a little background information, the design of the simulator is simple and easy to understand, which allows people to effectively learn about grain bin safety. It is felt that this project is very appealing to people involved in the agricultural world because of the importance of grain bin safety. Our project addresses improving grain bin safety for all. We hope to make a large impact on first responders as well as others who may not fully understand the danger of working in and around grain bins.

5 PROJECT SCOPE

At the beginning of the project our team was to design and build a new simulator. However, as the project progressed the scope changed to a design only project. Our team needed to design a new simulator to keep up to date with our client's current training needs. PRI wished to decrease the time necessary to train clients as well as enhance the training experience. Since our client is a small business and that our contact is the owner of the business that the majority of our client's business will be part of our project. However, since our client conducts several different types of training exercises and there are several members of their training staff our team will only be working with those members who directly work with the grain entrapment rescue simulator.

6 GRAPHICAL ABSTRACT

Figure 1-2: Key components that were redesigned during the project

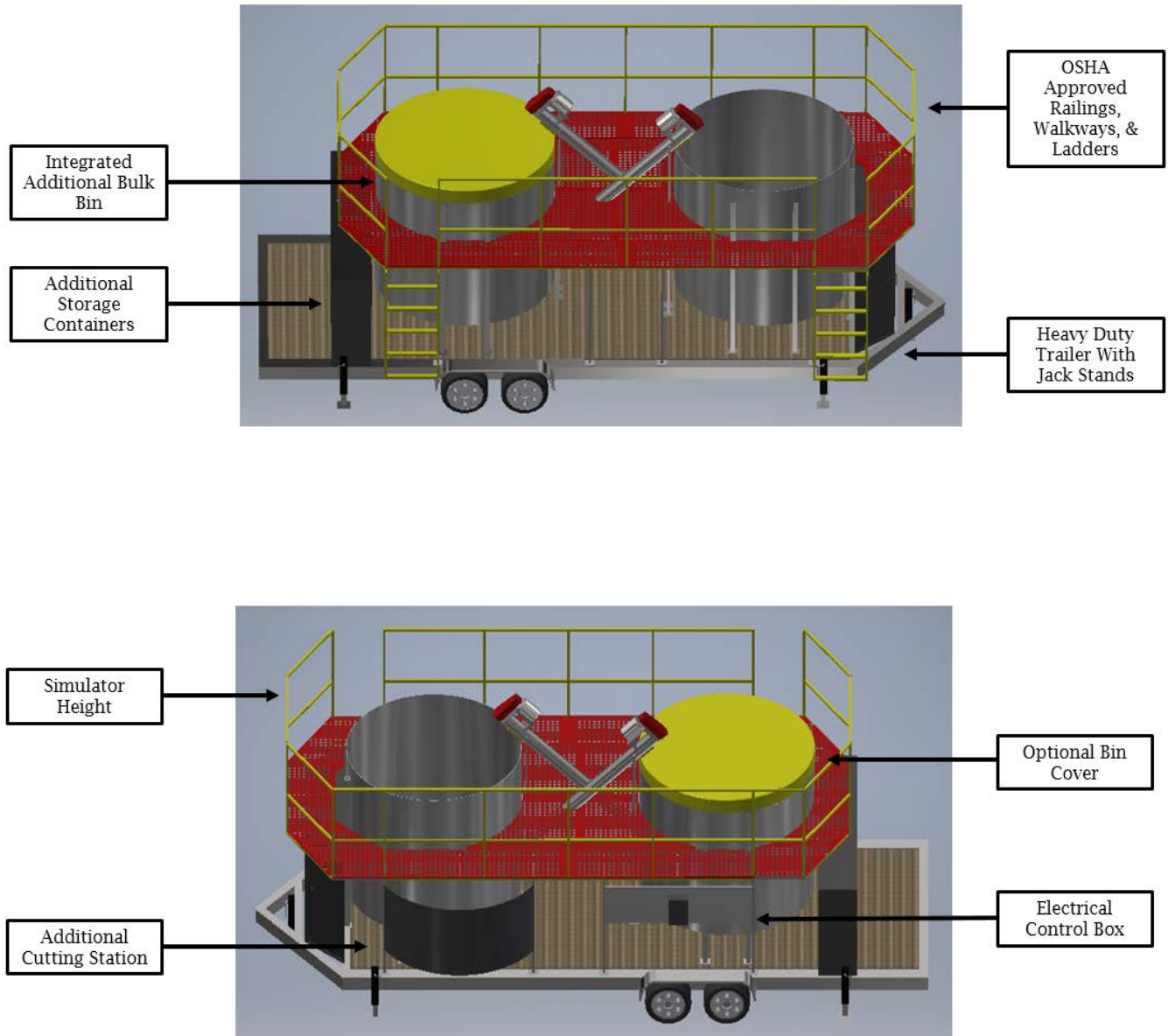
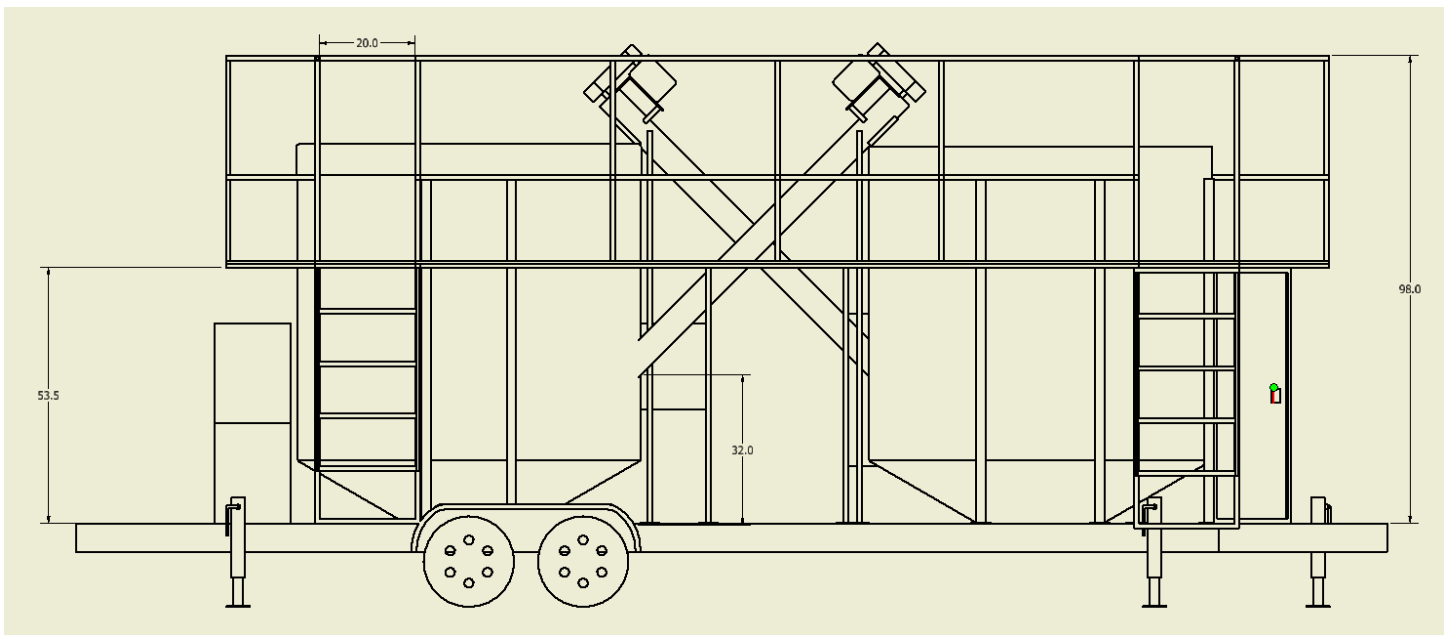
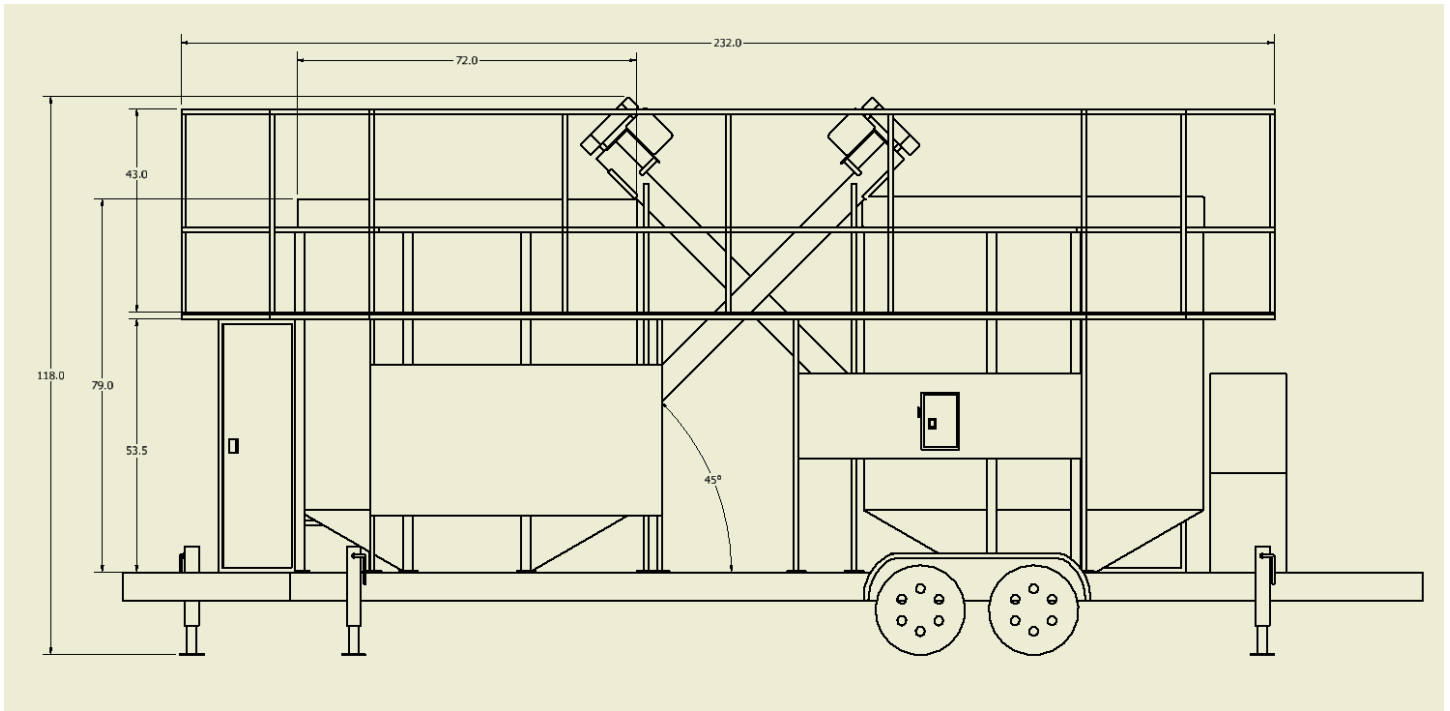
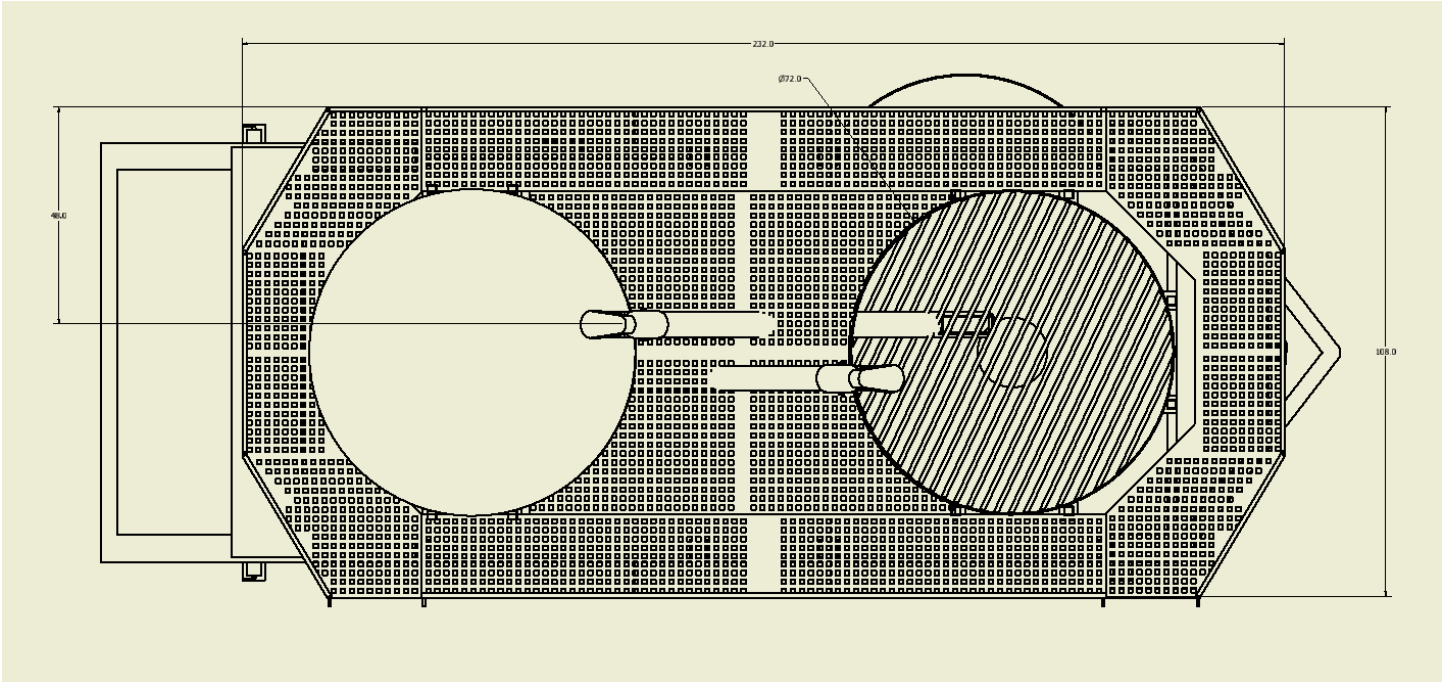

Figure 3-5: Drawing of trailer including basic deminsions





7 APPENDIXES

Appendix B:

I. Figure 6: Economical Comparison between existing simulator and new simulator.

Economical Comparison			
	Existing Simulator	New Simulator	Economical Gain
Training Time (20 Clients)	8 Hrs.	5 Hrs.	3 Hrs.
Max Class Size	20	36	16

II. Project objectives and constraints include:

Objectives:

- Add additional training features our client desired (cutting station, grain bin cover, bracketing system)
- Increase walk-way area
- Add additional bulk bin
- Increase grain flow
- Maintain trailer dimensions

Constraints:

- Integration of additional training features
- Reduce simulator height to less than 10 ft. tall
- Simulator must be placed on 20 ft. long, tandem axel, and bumper hitch car trailer
- Electrical circuit must be powered by 120 volt standard plug
- Truck and trailer weight must be within DOT regulations
- OSHA safety standards must be incorporated

Appendix C:

I. In order to ensure that all solutions our team suggested were correct, our team referenced several government and third party regulations. These included:

- PRI Grain Entrapment Training/Handbook Material: General understanding of grain entrapment rescue
- OSHA 1910.29(b): Sizing and dimensions of walkway guardrails
- OSHA 1910.23(b): Height and sizing of ladders
- OSHA 1910.27(d): Height of ladders requiring safety ladder hoops
- OSHA 1910.22(a): General overhead walkway regulations
- Iowa DOT: Iowa truck information guide
- NEC 690.8: Circuit sizing and current
- NEC 692.8: Circuit sizing and current
- NEC 694.12: Sizing of conductors and over current devices
- NEC 430.6: Motors, motor circuits, and controllers

II. Product/material information and sources referenced during the project. These sources include information used to determine dimensions, weight, price and other relevant information.

- Phone: Trailer Dimensions and Pricing (Diamond C Trailers)
- Phone: Bulk Bin Dimensions and Pricing (QC Supply Company)
- Phone: Auger/Motor Dimensions and Pricing (Westfield Augers)
- Online: Electrical Components Pricing (<https://www.automationdirect.com>)
- Online: Storage Components Dimensions and Pricing (<https://www.amazon.com/>)
- Online: Bin Cover Pricing and Dimensions (<https://www.tarpsnow.com/>)
- Online: Jack Stand Pricing and Dimensions (<https://www.amazon.com/>)
- In Person: Fabrication and Steel Expense (Trackside welding)

Figure 7: Necessary product pricing sheet.

MAIN COMPONENT LIST:				
QTY	DESCRIPTION	QUOTE NO.	UNIT PRICE	LINE TOTAL
1	Heavy Duty Trailer	001	\$ 5,495.00	\$ 5,495.00
2	Miniature Bulk Feed Bins	002	\$1,456.99	\$2,913.98
1	Needed Steel Material	003	\$3,000.00	\$3,000.00
2	Grain Auger	004	\$296.00	\$592.00
3	Horizontal Storage Boxes	005	\$502.95	\$1,508.85
1	Vertical Storage Box	006	\$550.25	\$550.25
2	Electric Motor Assembly	007	\$217.97	\$435.94
4	Jack Stands	008	\$57.55	\$230.20
2	Bin Cover	09	\$103.80	\$207.60
1	Electrical Components	010	\$1,045.33	\$1,045.33
TOTAL				\$15,979.20

III. Many of the past courses our team completed at Iowa State University were directly applicable to our project. These included:

- TSM 240: Introduction to Manufacturing for the knowledge of the manufacturing and assembly processes that was needed in order to complete this project.
- TSM 116, TSM 216, ME 170: Technical Graphics and Design for the knowledge and ability to use CAD software with confidence in order to properly create a design and rendering.
- TSM 332: Preservation of Grain Quality for the knowledge of how to properly move and handle grain both during training exercises and transport.
- TSM 363: Electric Power and Electronics for Agriculture and Industry for the knowledge and understanding of how to properly size, install, and wire the necessary electric motors and controls.
- TSM 443: Statics and Strength of Materials for Technology for the knowledge and understanding of how materials react to an applied load.

IV. Deliverables that our client will receive include:

Complete simulator design including detailed blueprints

Computer aided design drawing

Complete material list

Complete purchasing quote