

6-2006

# Demonstrating Electromagnetic Noise in an Undergraduate Measurement and Instrumentation Course

David Muff  
*Iowa State University*

Theodore J. Heindel  
*Iowa State University, theindel@iastate.edu*

Sriram Sundararajan  
*Iowa State University, srirams@iastate.edu*

Follow this and additional works at: [http://lib.dr.iastate.edu/me\\_conf](http://lib.dr.iastate.edu/me_conf)

 Part of the [Engineering Education Commons](#), [Mechanical Engineering Commons](#), and the [Science and Mathematics Education Commons](#)

---

## Recommended Citation

Muff, David; Heindel, Theodore J.; and Sundararajan, Sriram, "Demonstrating Electromagnetic Noise in an Undergraduate Measurement and Instrumentation Course" (2006). *Mechanical Engineering Conference Presentations, Papers, and Proceedings*. 51. [http://lib.dr.iastate.edu/me\\_conf/51](http://lib.dr.iastate.edu/me_conf/51)

This Conference Proceeding is brought to you for free and open access by the Mechanical Engineering at Iowa State University Digital Repository. It has been accepted for inclusion in Mechanical Engineering Conference Presentations, Papers, and Proceedings by an authorized administrator of Iowa State University Digital Repository. For more information, please contact [digirep@iastate.edu](mailto:digirep@iastate.edu).

---

# Demonstrating Electromagnetic Noise in an Undergraduate Measurement and Instrumentation Course

## **Abstract**

Electromagnetic noise (interference) is always present in a measurement system. The desire to minimize noise in your signal of interest can only be accomplished after the noise is properly identified. This paper summarizes a mechanical engineering undergraduate laboratory activity developed for ME 370 – Engineering Measurements and Instrumentation at Iowa State University. The goals of this activity are to (i) develop an understanding of how analog noise enters a measurement system and (ii) investigate several noise reduction methods. Students induce and measure capacitively coupled noise and investigate how the noise is related to noise source frequency and measurement circuit resistance. Methods to minimize capacitively coupled noise, including electrical shielding, are introduced and tested. Inductively coupled noise is then demonstrated, and the use of twisted pair wiring is shown to reduce this type of noise. Finally, conductively coupled noise is demonstrated through ground loops. Once this laboratory exercise is completed, students have an appreciation for how electromagnetic noise may be introduced into a measurement system, and how the effects of this noise can be minimized.

## **Disciplines**

Engineering Education | Mechanical Engineering | Science and Mathematics Education

## **2006-863: DEMONSTRATING ELECTROMAGNETIC NOISE IN AN UNDERGRADUATE MEASUREMENT AND INSTRUMENTATION COURSE**

### **David Muff, Iowa State University**

At the time of this laboratory development, David J. Muff was a graduate student in Mechanical Engineering at Iowa State University. He graduated with an MS degree in May 2005 and is currently employed as a Design Engineer with Vemeer Manufacturing in Pella, Iowa.

### **Theodore Heindel, Iowa State University**

Ted Heindel is the William and Virginia Binger Associate Professor of Mechanical Engineering at Iowa State University. He taught ME 370 at ISU from spring 2003 through spring 2005 and was responsible for major course modifications, including development of several new laboratory exercises. He is currently teaching thermal science courses, including fluid mechanics and heat transfer. He also has an active research program in multiphase flow characterization and visualization and gas-liquid mass transfer enhancement, and is the director of a one-of-a-kind X-ray facility used for flow visualization in large-scale opaque and multiphase flows.

### **Sriram Sundararajan, Iowa State University**

Sriram Sundararajan is an Assistant Professor of Mechanical Engineering at Iowa State University. Currently, he is teaching ME 370 and is continuing to update the course and associated laboratories to include contemporary issues in engineering measurements. He has also taught mechanical engineering design courses and has introduced courses in surface engineering and scanning probe microscopy into the ME curriculum at ISU. His research is in the area of experimental nanoscale tribology, surface mechanics, and surface engineering.

# Demonstrating Electromagnetic Noise in an Undergraduate Measurement and Instrumentation Course

## Abstract

Electromagnetic noise (interference) is always present in a measurement system. The desire to minimize noise in your signal of interest can only be accomplished after the noise is properly identified. This paper summarizes a mechanical engineering undergraduate laboratory activity developed for ME 370 – Engineering Measurements and Instrumentation at Iowa State University. The goals of this activity are to (i) develop an understanding of how analog noise enters a measurement system and (ii) investigate several noise reduction methods. Students induce and measure capacitively coupled noise and investigate how the noise is related to noise source frequency and measurement circuit resistance. Methods to minimize capacitively coupled noise, including electrical shielding, are introduced and tested. Inductively coupled noise is then demonstrated, and the use of twisted pair wiring is shown to reduce this type of noise. Finally, conductively coupled noise is demonstrated through ground loops. Once this laboratory exercise is completed, students have an appreciation for how electromagnetic noise may be introduced into a measurement system, and how the effects of this noise can be minimized.

## 1 Background

Mechanical Engineering Measurements and Instrumentation, commonly referred to as ME 370 at Iowa State University (identified as ME 370 in this paper), is a required course in the mechanical engineering undergraduate curriculum. The course covers various measurement and instrumentation topics, as well as data acquisition and analysis. Since electromagnetic noise is part of every measurement system<sup>[1-4]</sup>, it is important for students to be able to recognize its source. The goal of this paper is to describe laboratory activities that were initiated in ME 370 to demonstrate how electromagnetic noise is introduced in a measurement system, and how the effects of noise can be minimized.

The most common type of measurement noise is intrinsic noise, which is random noise that is always found in any physical circuit. The noise is manifested as a result of the laws of particle (electron) behavior on a microscopic scale. Thermal noise (also called Johnson or white noise) is an example of intrinsic noise; it is due to random vibrations of electrons in a conductor and will be present at any temperature above 0K. This type of noise is not the focus of this ME 370 laboratory activity or this paper.

Interference noise is caused by an unwanted stray signal that is electromagnetically coupled to a measurement circuit from a nearby source via various means. This type of noise directly affects measurement systems. The most common type of interference noise is line noise (e.g., 60 Hz in North America). Line noise can enter into a measurement system in a variety of ways including close proximity to power cords or industrial equipment, poor grounding techniques, and/or the use of poorly designed measurement systems. In general, interference

noise (which will simply be referred to as noise for the remainder of this paper) is electromagnetically coupled to the measurement circuit by one or a combination of three modes: (i) capacitive, (ii) inductive, or (iii) conductive. The activities summarized in section 3 demonstrate each of these modes to the students in ME 370 and describes various techniques to minimize their impact on a measurement system.

## 2 Laboratory Equipment

Table 1 lists the needed equipment to complete this laboratory activity. The two main components are a National Instruments Educational Laboratory Virtual Instrumentation Suite (NI-ELVIS) workstation connected to a computer running the LabVIEW 7.0 virtual oscilloscope. This will allow NI-ELVIS to function as an oscilloscope. A separate function generator (BK Precision) and voltmeter (RadioShack 22-813) are also used in this activity. However, the NI-ELVIS workstation could be used in place of these components while running the associated virtual instruments. Also, any stand-alone oscilloscope could be used in place of NI-ELVIS.

Table 1: Laboratory equipment used in this activity.

Equipment	Quantity
Computer running LabVIEW 7.0 virtual oscilloscope	1
NI-ELVIS workstation	1
Function generator	1
Resistor block (a breadboard with several resistors in series)	1
BNC cables	2
Banana cables	3
Banana cable pair wrapped in aluminum foil	1
Banana-BNC converter (adapter)	2
Unshielded power cable	1
Shielded power cable	1
Alligator clip	1
Shielded wire coil with BNC connection	1
Non-twisted wire pair with BNC connection	1
Twisted wire pair with BNC connection	1
Ground from a second device (e.g., Tektronix Oscilloscope)	1
Voltmeter	1

Several items listed in Table 1 were fabricated for this laboratory activity; they include:

1. A resistor block (Fig. 1): This is simply a RadioShack breadboard with several resistors connected in series. This device acts as an adjustable resistance “measurement device”. No voltage is intentionally applied across the resistor block terminals. Hence, any recorded voltage is only the result of noise coupling to the “measurement device”.
2. A banana cable pair wrapped in aluminum foil: A pair of banana cables are wrapped in aluminum foil to simulate a shielded wire pair. An alligator clip is attached to the aluminum foil and then grounded to provide the required shield grounding connection.
3. A shielded wire coil with BNC connection (Fig. 2): This is a spool of wire with the wire ends connected to the BNC connection. When an AC signal is connected to the BNC terminal, a magnetic field is produced to demonstrate inductive coupling (see section 3.2 below). The

aluminum foil shield is grounded with an alligator clip connect to the source ground to reduce the effects of capacitive coupling.

4. Twisted and non-twisted wire pairs connected to a BNC connection (Fig. 2): These devices are used in the inductive coupling activity. One end of each wire pair is connected to the BNC connection while the other end of each pair is soldered together to complete the circuit. In this case, the wire is, in fact, a thermocouple but any sensing element would also exhibit similar inductive coupling.

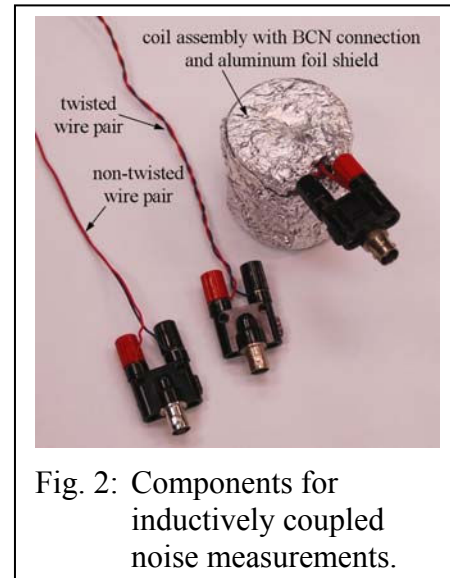
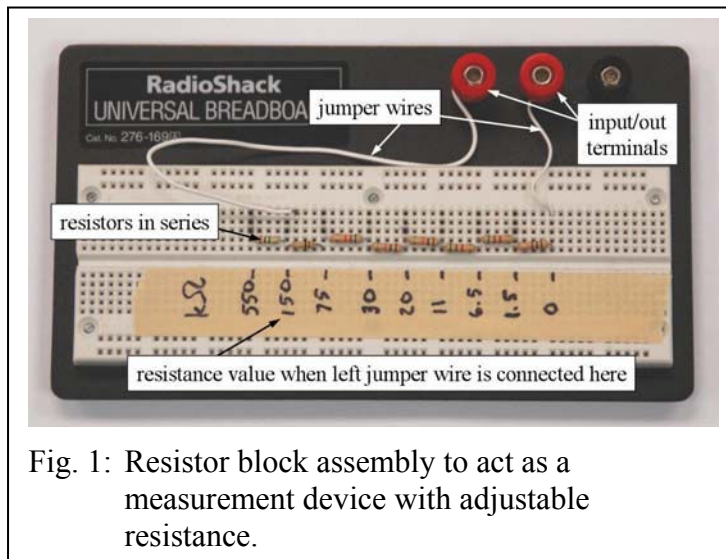

### 3 Laboratory Activities

Several laboratory activities were developed to demonstrate capacitively coupled, inductively coupled, and conductively coupled noise in a measurement circuit. The activities described below are designed to take students approximately 90 minutes to complete. Our ME 370 laboratory sections are 3 hours long and the noise demonstrations are the second part of a two-part weekly laboratory; the first part covers filters, which are devices that may be used to suppress noise in a measurement system. The noise-related activities will now be summarized.

#### 3.1 Capacitively Coupled Noise

Capacitively coupled noise originates from electric fields traveling through space. Stray capacitance between circuits (typically the wires) exist and provide a mode of unwanted coupling. In Fig. 3, a typical setup for measuring the voltage across a sensor or load has been subjected to unwanted coupling to the noise source via stray capacitance. In this setup, the sensor has an equivalent resistance  $R_s$  and the noise source is an AC signal with an amplitude  $V_{\text{noise}}$ . The capacitive coupling induces a current ( $I_{\text{noise}}$ ) in the measurement circuit. This is manifested as an induced voltage across the instrument load  $R_s$ . Hence for a given noise-induced current, the noise voltage is directly proportional to the load resistance. Increasing the capacitance (e.g., placing the noise source closer to the instrument load) will increase the noise current and hence the resulting noise voltage in the measurement circuit. Due to the capacitive nature of the coupling, only time-varying signal source voltages, such as a 60 Hz line voltage, will induce noise in the circuit.

To demonstrate capacitive coupling in the laboratory, the resistor block (Fig. 1) is used as a model variable resistance measurement device, with a total resistance set at 550 k $\Omega$ . As shown in Fig. 4, banana cables are connected to the input/output terminals of this device and then the cables are connected to a BNC connector. The banana cables simulate the instrument positive and negative wires while the resistor block represents a measurement device. A coaxial cable is then used to connect the BNC connector to the NI-ELVIS BNC 1 terminal.

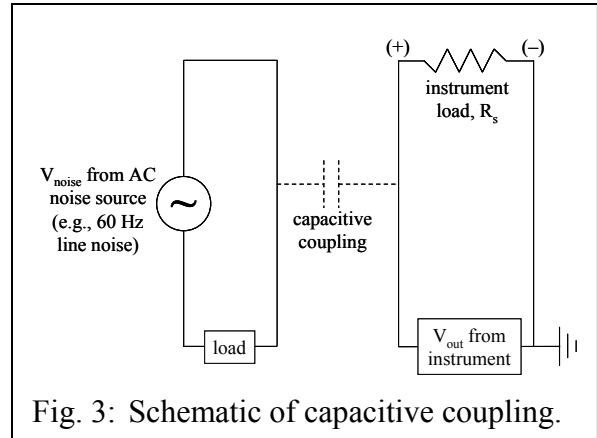

Fig. 3: Schematic of capacitive coupling.

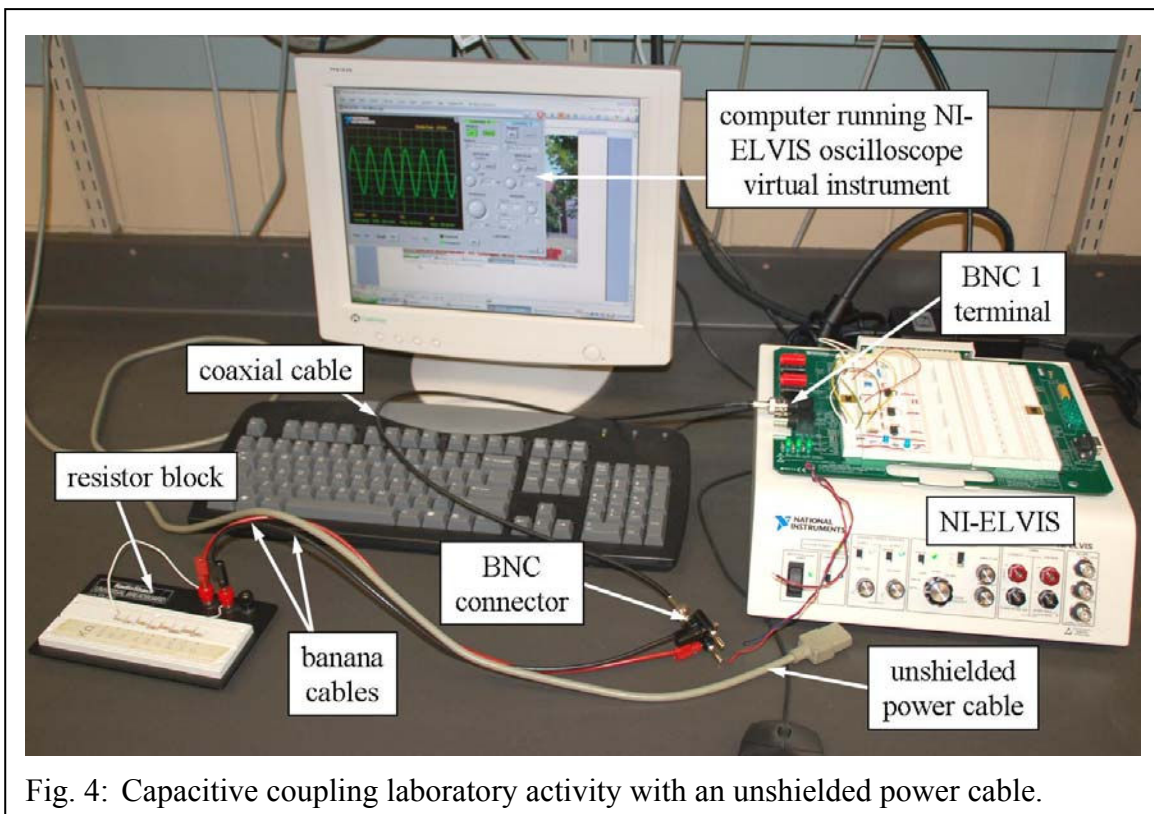

Fig. 4: Capacitive coupling laboratory activity with an unshielded power cable.

Additional connections are made using jumper wires on the NI-ELVIS breadboard as follows: BNC 1 (-) is connected to the NI-ELVIS ground, BNC 1 (+) is connected to the oscilloscope CH A (+), and the oscilloscope CH A (-) is connected to the NI-ELVIS ground. The NI-ELVIS virtual oscilloscope should be installed and running on the laboratory computer. Note that Fig. 4 shows several other items on the NI-ELVIS breadboard; these are not used in the noise activities described here, but are used in other ME 370 laboratory activities that are not the focus of this paper.

Figure 4 also shows an unshielded power cable that is plugged into a wall outlet, but not connected to any device. This cable has a 120 V potential that is varying at approximately 60 Hz.



Since the cable is unshielded, there is capacitive coupling between this cable and the banana cables that are connected to the resistor block. Figure 5 shows a schematic of this setup.

Figure 6 shows a sample of the NI-ELVIS oscilloscope output for the configuration shown in Fig. 4. The oscilloscope settings are adjusted as follows: the display for channel A is turned on while channel B is turned off, the source is selected as “BNC/Board CH A”, the trigger source is set to “CH A”, and the vertical and timebase scales are adjusted to get several waveforms completely on the screen. We note that the minimum sampling rate used in the measurement is 10 kHz, which is well above the Nyquist criterion value for a 60 Hz line signal. The “MEAS” button for channel A is also turned on; this activates the “RMS”, “Freq”, and “Vp-p” measures located below the waveform display. By moving the unshielded power cable closer or farther away from the banana cables, the amplitude of the induced voltage shown in Fig. 6 will increase or decrease, respectively. To maximize the induced voltage amplitude, the unshielded power cable may be wrapped around the banana cable “instrument” wires several times. Students are asked to record the induced noise frequency and RMS voltage as reported on the oscilloscope output for various instrument load resistances.

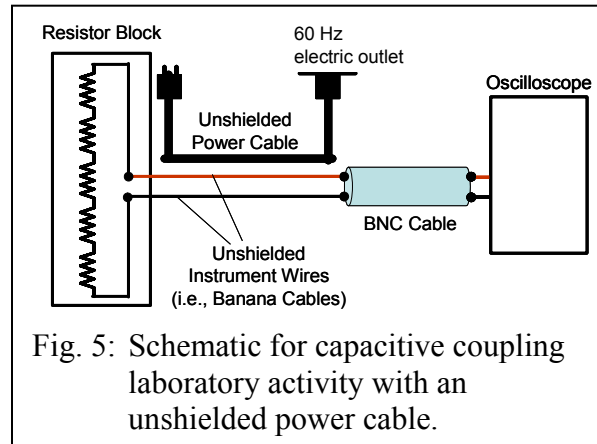

Fig. 5: Schematic for capacitive coupling laboratory activity with an unshielded power cable.

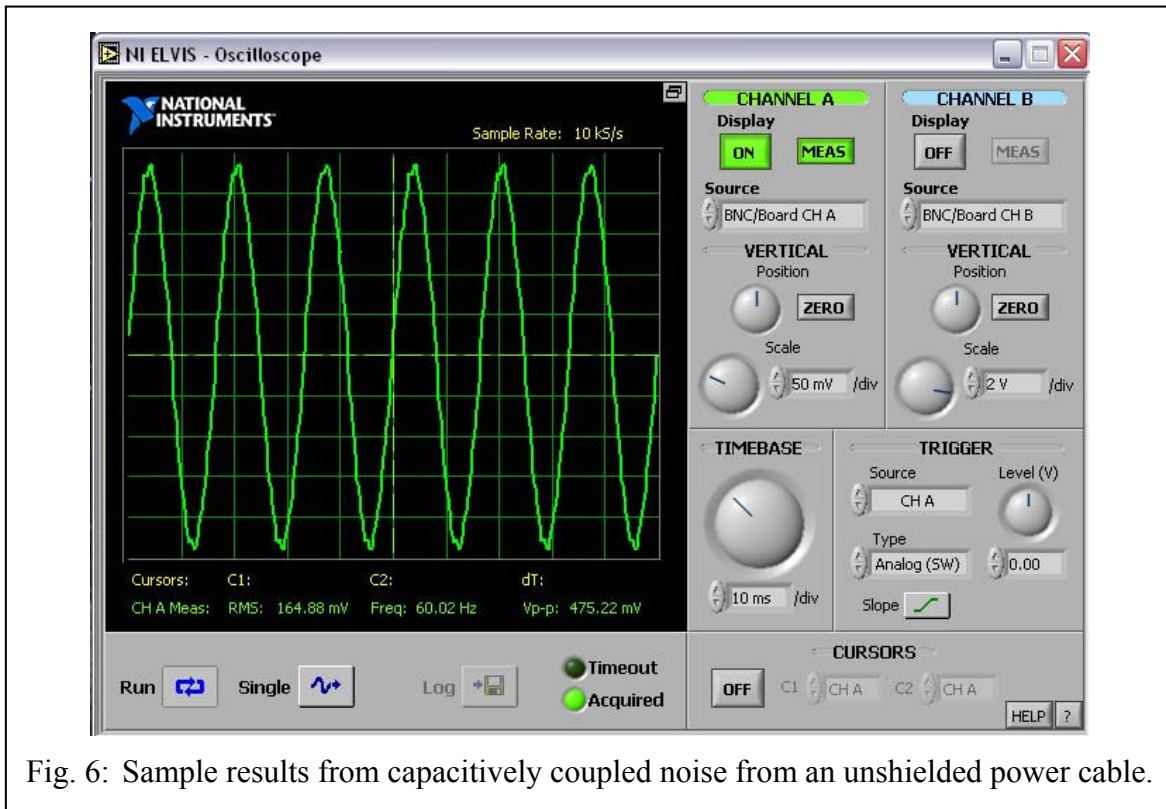

Fig. 6: Sample results from capacitively coupled noise from an unshielded power cable.



After students experiment with the position of the unshielded cable, it is replaced with a shielded power cable. The shielded power cable is plugged into the wall outlet and placed adjacent to the banana cables in a similar fashion as the unshielded power cable. Students again record the induced noise frequency and RMS voltage values for a range of instrument load resistances.

Students are then asked to replace the unshielded banana cables with a pair of banana cables that are wrapped in aluminum foil (Fig. 7). An alligator clip is attached to the aluminum foil and then grounded at the noise source ground to produce a grounded shield for the instrument load wires. The unshielded power cable is then placed adjacent to the banana cables that are shielded and grounded, and the induced noise frequency and RMS voltage are again recorded over a range of instrument load resistances.

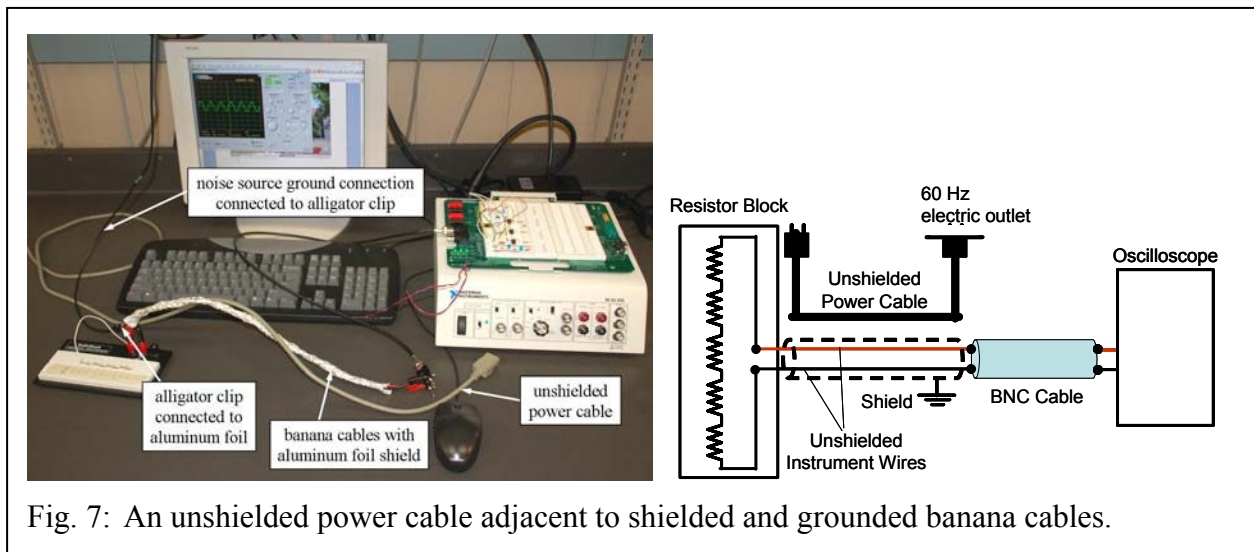

Fig. 7: An unshielded power cable adjacent to shielded and grounded banana cables.

Table 2 shows sample output from the above experiments. From these results, students observe that unshielded connections produce the highest induced noise voltage, and this induced voltage increases with increasing instrument load resistance. They also notice that a shielded power cable should be used if possible (ensuring that there is a ground connection to the shield). However, even with a shielded power cable, there is still some induced noise at the higher instrument load resistances, and this is likely due to extraneous 60 Hz noise that is in the lab. Finally, they should realize that they can shield their own system simply by wrapping all connections with aluminum foil and then grounding the aluminum foil at a single ground (typically the source ground). They can also see what happens when they remove the ground connection to the aluminum foil – it is as if there is no shielding; thus, they conclude that the ground connection is essential to suppressing the noise. Finally, students are asked to discuss why their induced noise voltages with the shielded banana cables are not as low as those with the shielded power cable; they (hopefully) realize that the aluminum foil shielding is not perfect and there are still regions that are unshielded, like the resistor block and where the banana cables connect to the BNC connector (Fig. 7).

Table 2: Sample output from the capacitively coupled experiments.

	Unshielded Banana Cables				Shielded Banana Cables	
	Unshielded Power Cable		Shielded Power Cable		Unshielded Power Cable	
Instrument Load Resistance (k $\Omega$ )	Noise Frequency (Hz)	Noise V <sub>RMS</sub> (mV)	Noise Frequency (Hz)	Noise V <sub>RMS</sub> (mV)	Noise Frequency (Hz)	Noise V <sub>RMS</sub> (mV)
550	61.3	126	61.3	3.2	61.8	44.3
75	61.8	10.6	-	0	61.3	4.7
20	-	0	-	0	-	0

Next, the effect of noise source frequency is demonstrated. Students replace the shielded banana cables with unshielded banana cables and unplug the shielded and unshielded power cables. A coaxial cable is then connected to the function generator and a BNC connector is attached to the opposite end of the coaxial cable. A banana cable is connected to the positive (+) terminal of the BNC connector; this line represents a variable frequency unshielded noise source (Fig. 8). The most consistent results appear when the variable frequency unshielded noise source is wrapped around the resistor block wires (banana cables) several times. Figure 9 shows sample output observed on the NI-ELVIS oscilloscope when the noise source frequency is 1 kHz and the instrument load resistance is 550 k $\Omega$ . We note that the minimum sampling rate for the oscilloscope for these experiments was 50 kHz.

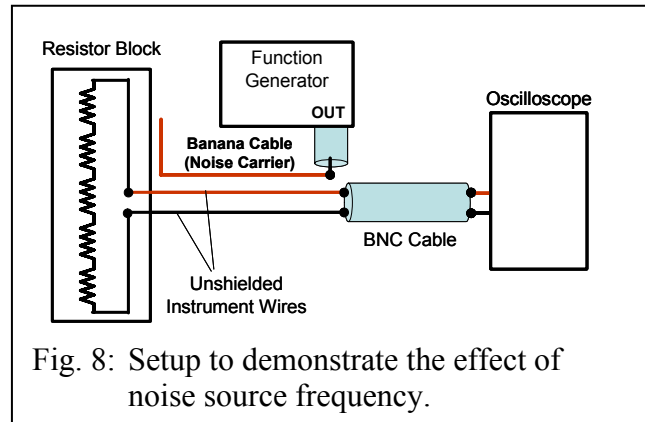

Fig. 8: Setup to demonstrate the effect of noise source frequency.

Note that Fig. 9 shows what appears to be a second (lower) frequency embedded in the 1 kHz sign wave. This second noise source is likely due to additional 60 Hz noise that is not completely eliminated from the setup; this is also observed above (Table 2) when induced noise is recorded when using the shielded power cable and an instrument load resistance of 550 k $\Omega$ .

Students explore the effect of noise source frequency and instrument load resistance by varying both parameters and recording the induced RMS voltage. Table 3 shows selected results. Students observe that increasing the noise source frequency and instrument load resistance increases the induced noise voltage. Students should interpret these results as due to the capacitive nature of the coupling that allows high-frequency content through easier than low-frequency content, and due to the fact that the noise is manifested as a current, respectively. This also implies that DC noise (DC offset) cannot be attributed to capacitive coupling since capacitors have infinite resistance to DC current.

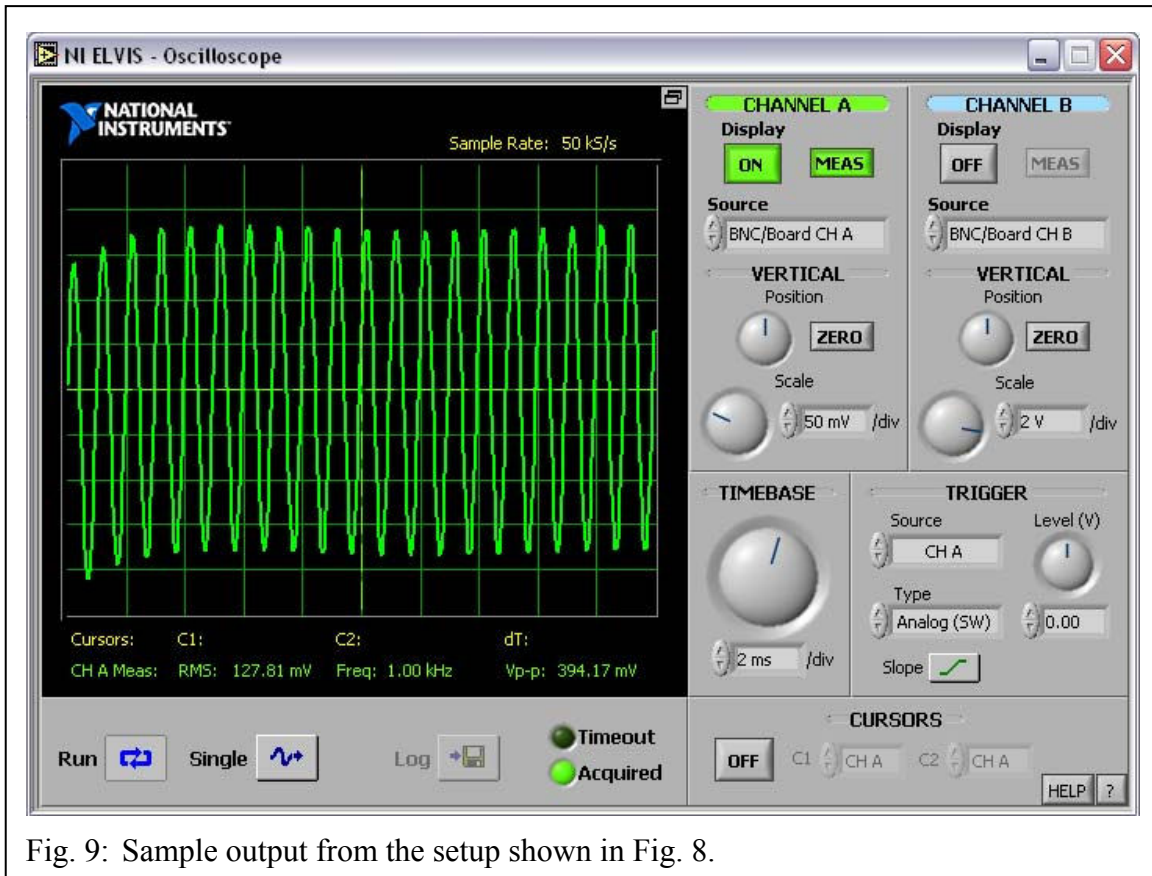

Fig. 9: Sample output from the setup shown in Fig. 8.

Table 3: Effect of noise source frequency on induced noise voltage.

Instrument Load Resistance (kΩ)	Noise $V_{RMS}$ at 1 kHz (mV)	Noise $V_{RMS}$ at 10 kHz (mV)
550	131	147
75	38	125
20	10	74

### 3.2 Inductively Coupled Noise

Any circuit whose current varies with time (such as circuits involving electromotive elements) will create a changing magnetic field (B) such that it satisfies:

$$\frac{dB}{dt} = L \frac{dI}{dt} \quad (1)$$

where L is the equivalent inductance of the circuit. Recall that the right hand term in the equation is equal to the voltage across the inductor. This induced noise voltage can be superimposed on top of sensor output voltage in a measurement circuit by this mechanism if the two circuits are in proximity. Also, if sensor wires are vibrating or shifting at high speeds through a constant

magnetic field, an induced noise voltage can also be generated. Thus, inductive coupling can induce a voltage in the measurement circuit. Any circuit whose current changes with time can contribute noise via inductive coupling. Common sources include fans, motors, transformer coils, etc. Also, magnetically coupled pumps can also produce inductive coupling. Since the coupling is electromagnetic, the orientation of the wires with respect to the changing magnetic field can alter polarity of the coupling.

Knowing that the positions of the lead wires can affect the phase of the induced voltage, a simple type of inductive noise cancellation can be obtained from twisted pair wiring. In twisted pair wiring, the positive and negative lead wires are twisted together to form multiple twist sets so that any changing magnetic field that pierces a twist set will induce a current that cancels currents induced in neighboring twist sets. In Fig. 10, twist sets a, b, and c are all subjected to the same changing magnetic field and each twist set generates a corresponding loop current to oppose the changing magnetic field. Overall, if the twist sets are small enough, then the magnitude of the changing magnetic field can be assumed constant over a specified length of wire and the net induced noise current (and noise voltage) in the circuit will be zero.

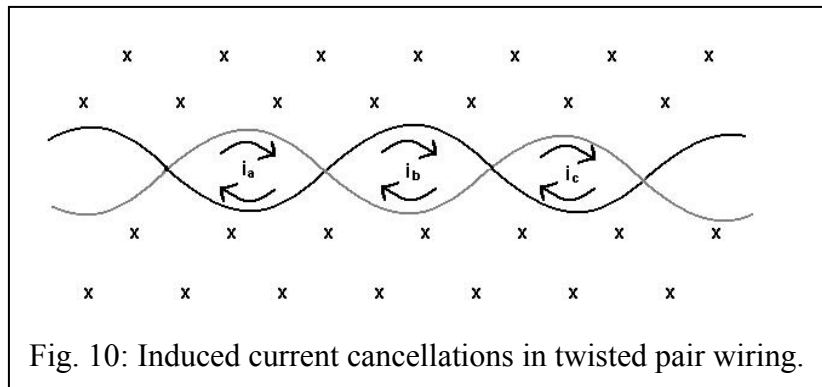

Inductive coupling is demonstrated in the laboratory by generating a magnetic field using a coil of wire with an imposed high frequency sine wave. The ends of the wire coil are connected to a BNC connector, which is then connected to the function generator (Fig. 11). The shield around the coil assembly shown in Fig. 11 is obtained by wrapping the wire coil in aluminum foil and then grounding it with an alligator clip connected to the source ground. This configuration minimizes capacitive coupling to allow the students to focus on the effects of inductive coupling. A non-twisted wire pair is connected to a BNC connector, which is connected to BNC 1 in NI-ELVIS with a coaxial cable. This allows the induced voltage to be observed on the NI-ELVIS virtual oscilloscope.

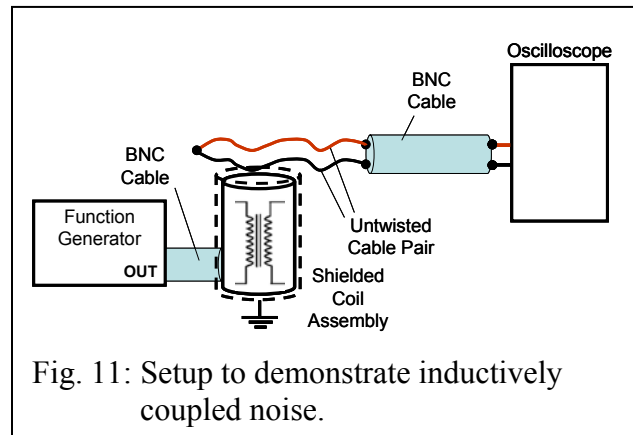

The function generator is set at 20 kHz and the sine wave output amplitude is set to its maximum value. We note that the minimum sampling rate for the oscilloscope for these experiments was 500 kHz. Students place the non-twisted wire pair over the top of the coil assembly such that the wires are side-by-side ( $0^\circ$  configuration). In this position, the maximum amount of magnetic flux will pass between the area enclosed by the wires. To allow the students

to observe and record the induced noise RMS voltage, the oscilloscope vertical scale for channel A may have to be set to the smallest value (10 mV/div). Figure 12 shows sample output from the NI-ELVIS virtual oscilloscope. Note that although the measured induced voltage has a frequency of 19.95 kHz (the function generator value), the amplitude is not very high (363  $\mu$ V).

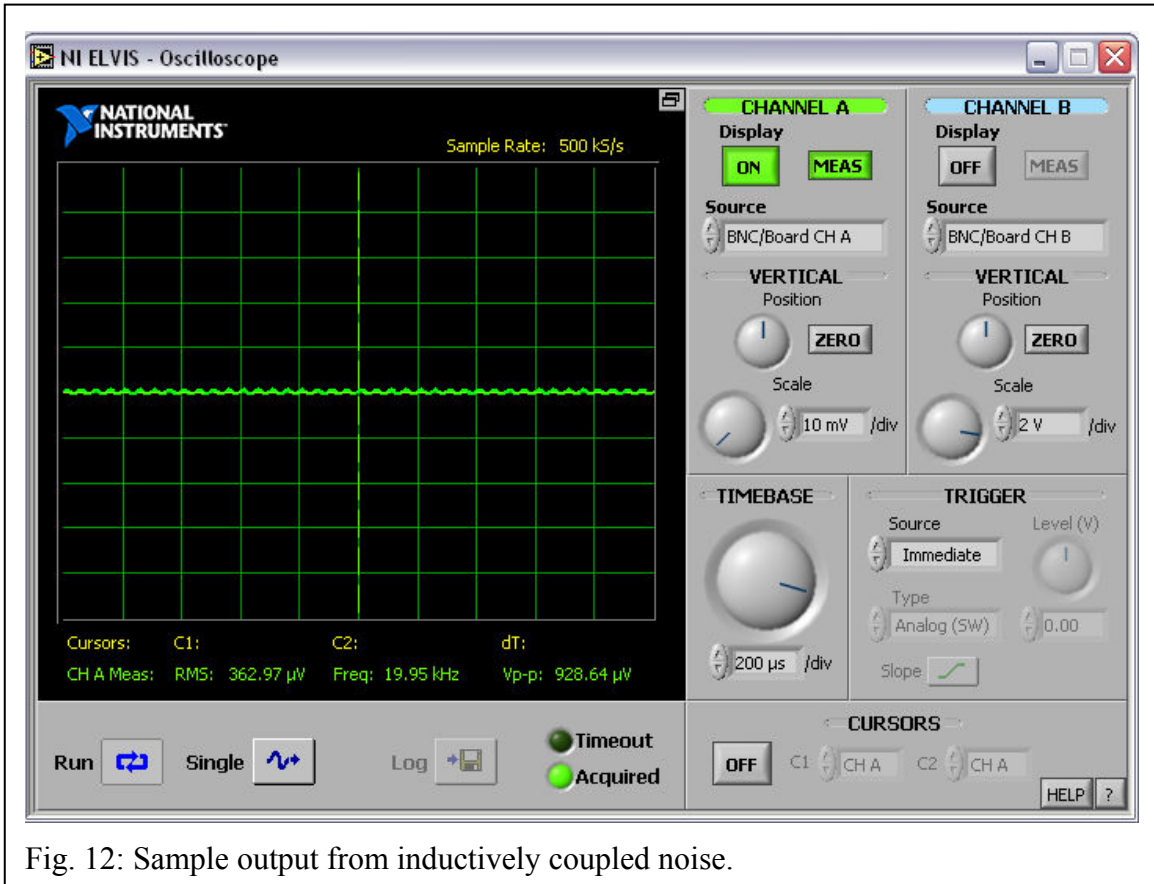

Fig. 12: Sample output from inductively coupled noise.

By rotating the non-twisted wire pair 90°, such that they are now stacked on top of one another on the coil assembly, the magnetic field relative to the wires will change and alter the induced voltage. Students record the induced voltage for the non-twisted pair wire in both the 0° and 90° configuration. Students then replace the non-twisted pair wire with a twisted pair wire and again record the induced voltage. Table 4 summarizes typical results. Note that the magnetic field piercing the conductor loop should be zero at 90°, but imperfections in the angle at which it is actually held in place leads to a modest amount of inductive coupling. Students are then asked to discuss their results.

Table 4: Typical inductively coupled noise voltages.

Wire configuration	Noise $V_{RMS}$ ( $\mu$ V)
Non-twisted at 0°	363
Non-twisted at 90°	160
Twisted pair	50

### **3.3 Conductively Coupled Noise**

The final type of noise demonstrated in the laboratory activity is conductively coupled noise, which is primarily the result of ground loops. Ground loops are caused when the “ground” (a better term for “ground” is actually reference voltage) for different components in your circuit may, in reality, be different. The presence of such a ground loop will generate noise currents and hence, voltages in your measurement circuit. Ground loops are prevented by using a common ground in your measurement circuit.

Ground loops are demonstrated in this laboratory actively by first disconnecting all components. The breadboard on NI-ELVIS is then setup such that Banana A is wired to the NI-ELVIS ground. A banana cable then is connected from Banana A on NI-ELVIS to one terminal on a handheld multimeter set to read voltage. A second banana cable is then connected between the ground from the Tektronix oscilloscope located in our ME 370 laboratory (any other device with a ground connection could also be used) and the handheld multimeter. The multimeter, set to read voltage, is now recording the voltage between two ground (reference) points. The resulting voltage is recorded, with a typical result on the order of 80 mV. Note that this value is finite because the NI-ELVIS workstation is plugged into a different circuit than the Tektronix oscilloscope. Also, the computer connected to NI-ELVIS (and running LabVIEW) should be on the same circuit as NI-ELVIS since it could generate a ground loop through the DAQ cable. This simple demonstration shows students that not all “grounds” are equal, and a common ground must be used to minimize noise from ground loops.

## **4 Activity Extensions**

Capacitively coupled noise could be extended to demonstrate common mode voltages by removing the ground connection to the negative wire in Fig. 3. When this is done, capacitive coupling is also connected to the negative instrument load connection. If this coupling is identical for the positive and negative instrument load wires, a differential amplifier could be used to eliminate the capacitively coupled noise. Hence, the effectiveness of a differential op-amp could be demonstrated. A discussion on common mode voltages, common mode rejection ratio (CMRR), and single-ended and differential-ended voltage measurements and data acquisition cards could also be included.

Inductively coupled noise activities could be extended by locating non-twisted pair measurement wires near an unshielded magnetically-coupled motor and then isolate the frequency of the induced noise through FFT analysis. The effects of switching to twisted pair measurement wires, and the extent of the number wire twists, could also be demonstrated.

Conductively coupled noise activities could be extended by testing the ground loop voltage between several different pieces of laboratory equipment. A device could also be fabricated to measure the voltage potential from the third prong (ground pin) of various wall outlets, and students could comment on their results.

## **5 Conclusions**

Activities have been developed to demonstrate conductively coupled, inductively coupled, and conductively coupled noise in a mechanical engineering undergraduate laboratory

setting. The influence of noise source frequency and measurement circuit resistance on capacitively coupled noise was demonstrated. Methods to minimize measurement noise, including electrical shielding for capacitively coupled noise, twisted pair wiring for inductively coupled noise, and common grounds for conductively coupled noise, were introduced and tested. By completing these laboratory activities, students have developed an appreciation for how electromagnetic noise may be introduced into a measurement system, and how the effects of this noise can be minimized.

### **Acknowledgements**

Initial support for modifications to ME 370, including development of this laboratory activity, was provided through a 2003-2004 Iowa State University Miller Faculty Fellowship Grant, the Department of Mechanical Engineering, and the College of Engineering. The assistance of Mr. James Dautremont in developing this laboratory activity is greatly appreciated.

### **Bibliography**

1. Bentley, J.P., *Principles of Measurement Systems*, 2<sup>nd</sup> Edition, Essex, England: Longman Scientific & Technical (1988).
2. Doebelin, E.O., *Measurement Systems Application and Design*, 5<sup>th</sup> Edition, New York: McGraw-Hill (2004).
3. Dunn, P.F., *Measurement and Data Analysis for Engineering and Science*, New York: McGraw-Hill (2005).
4. Wheeler, A.J., and Ganji, A.R., *Introduction to Engineering Experimentation*, 2<sup>nd</sup> Edition, Upper Saddle River, New Jersey: Pearson Education, Inc. (2004).