

2011

Magnetic pulse generation for high-speed magneto-optic switching

Sasha Kemmet
Iowa State University

Mani Mina
Iowa State University, mmina@iastate.edu

Robert J. Weber
Iowa State University

Follow this and additional works at: http://lib.dr.iastate.edu/ece_pubs



Part of the [Electromagnetics and Photonics Commons](#)

The complete bibliographic information for this item can be found at http://lib.dr.iastate.edu/ece_pubs/58. For information on how to cite this item, please visit <http://lib.dr.iastate.edu/howtocite.html>.

This Article is brought to you for free and open access by the Electrical and Computer Engineering at Iowa State University Digital Repository. It has been accepted for inclusion in Electrical and Computer Engineering Publications by an authorized administrator of Iowa State University Digital Repository. For more information, please contact digirep@iastate.edu.

Magnetic pulse generation for high-speed magneto-optic switching

Abstract

In this article, the magnetic pulse characteristics needed to achieve high-speed magneto-optic (MO) switching are investigated. A fiber-based, MO, low-voltage optical switch capable of 200 ns switching is presented, along with the special circuit characteristics for magnetic field generation for high-speed switching. The switch consists of the optical system, the MO material (bismuth substituted iron garnet $[(\text{Bi}_{1.1}\text{Tb}_{1.9})(\text{Fe}_{4.25}\text{Ga}_{0.75})\text{O}_{12}]$), and a high-speed magnetic field driving circuit. A Faraday rotator is placed within the interferometric loop of a fiber-optic Sagnac interferometer, and interference at the output ports is controlled by the applied field. The fast switching speed is accomplished via the special design of the magnetic pulse generation circuitry. The applied magnetic field overshoots the field necessary to achieve the desired Faraday rotation and then settles to a steady state field. If the duration of the overshoot is less than the time it takes the material to saturate, a fast optical switching time can be achieved without saturating the material. The effects of the overshoot amplitude and duration and steady-state amplitude on optical rise time (determined by domain wall velocity) are studied and experimental results are presented.

Keywords

applied field, applied magnetic fields, domain wall velocities, Faraday rotations, Faraday rotators, fast switching, high-speed switching, iron garnet, low-voltage, magnetic pulse, Ms switching, optic switching, output ports, risetimes, sagnac interferometer, gallium

Disciplines

Electrical and Computer Engineering | Electromagnetics and Photonics

Comments

The following article appeared in *Journal of Applied Physics* 109 (2011): and may be found at doi: [10.1063/1.3549632](https://doi.org/10.1063/1.3549632).

Rights

Copyright 2011 American Institute of Physics. This article may be downloaded for personal use only. Any other use requires prior permission of the author and the American Institute of Physics.

Magnetic pulse generation for high-speed magneto-optic switching

Sasha Kemmet,^{a)} Mani Mina, and Robert J. Weber

Department of Electrical and Computer Engineering, Iowa State University, Ames, Iowa 50111, USA

(Presented 16 November 2010; received 24 September 2010; accepted 10 November 2010; published online 14 April 2011)

In this article, the magnetic pulse characteristics needed to achieve high-speed magneto-optic (MO) switching are investigated. A fiber-based, MO, low-voltage optical switch capable of 200 ns switching is presented, along with the special circuit characteristics for magnetic field generation for high-speed switching. The switch consists of the optical system, the MO material (bismuth substituted iron garnet $[(\text{Bi}_{1.1}\text{Tb}_{1.9})(\text{Fe}_{4.25}\text{Ga}_{0.75})\text{O}_{12}]$), and a high-speed magnetic field driving circuit. A Faraday rotator is placed within the interferometric loop of a fiber-optic Sagnac interferometer, and interference at the output ports is controlled by the applied field. The fast switching speed is accomplished via the special design of the magnetic pulse generation circuitry. The applied magnetic field overshoots the field necessary to achieve the desired Faraday rotation and then settles to a steady state field. If the duration of the overshoot is less than the time it takes the material to saturate, a fast optical switching time can be achieved without saturating the material. The effects of the overshoot amplitude and duration and steady-state amplitude on optical rise time (determined by domain wall velocity) are studied and experimental results are presented. © 2011 American Institute of Physics. [doi:10.1063/1.3549632]

Over the past few decades, the communication network has transitioned to a hybrid electrical and optical network, with medium- and long-haul data transmission occurring in the optical domain and processing functions remaining in the electrical domain. At the hardware level, the key to realizing the bandwidth capabilities of optical fiber is optical switches.¹ As optical networks transition toward optical switching, magneto-optic (MO) devices offer excellent promise for path defining switching due to their low insertion loss, their ability to be integrated,^{2,3} recent material advances,^{4,5} and the nonreciprocity of the induced Faraday rotation. Recent MO switches have been proposed, but their switching speed has been limited to approximately 1 μs .^{6–8} Specialized coil designs have been proposed to increase switching time.⁹ Some minor improvements have been made by using a high voltage (over 100 V) for magnetic field generation,¹⁰ but for device application, it is desirable to achieve switching with low voltages. The proposed switch, capable of switching times of less than 200 ns, offers faster switching speeds than technologies that are currently being implemented (primarily micro-electro-mechanical systems (MEMS) based switches) and can be implemented at a much lower cost than switches with faster or comparable switching speeds.

The switching time of MO optical switches is determined by how quickly the MO material can be magnetized in order to achieve the desired Faraday rotation of the optical signal. Early approaches focused on increasing the rise time of the current in the magnetic field generating coil; however, the electronic rise time in such systems was approximately 1 order of magnitude faster than the optical rise time.⁷ Continuing to increase the amplitude of the magnetic field applied to the MO material will increase the rise time of the optical signal; however, it is

critical to avoid saturating the material and causing permanent domain pinning. In addition, applying a magnetic field that results in a Faraday rotation that is greater than necessary degrades the performance of the switch. It is proposed that by modifying the applied field with a prepulse, the optical rise time can be improved while avoiding saturation of the material, even if the prepulsed field is greater than the saturation field. This study investigates the effect of a prepulsed magnetic field on the optical rise time by controlling the overshoot rise time, amplitude, and duration.

The proposed switch consists of a Sagnac interferometer with a magneto-optic Faraday rotator (MOFR) placed in the interferometer loop as shown in Fig. 1. An incoming signal at port 1 is split by the 3-dB coupler into two counter-propagating signals exiting port 3 and port 4, with the coupler introducing a $\pi/2$ phase shift between the two exiting signals. The output at ports 1 and 2 is determined by the Faraday rotation induced in the signals and can be described by:

$$\begin{pmatrix} E_{1-} \\ E_{2-} \end{pmatrix} = T e^{-j\phi} \begin{bmatrix} (jE_{1x+} \cos \theta)\hat{x} + (jE_{1y+} \cos \theta)\hat{y} \\ (-E_{1y+} \sin \theta)\hat{x} + (E_{1x+} \sin \theta)\hat{y} \end{bmatrix} \quad (1)$$

where E_{1-} and E_{2-} are the waves leaving ports 1 and 2, respectively, E_{1x+} and E_{1y+} are the x and y components of the optical signal entering port 1, θ is the Faraday rotation experienced by the wave, T is the transmission coefficient of the MOFR, and ϕ is the phase shift experienced by the counter-propagating waves due to the length of the interferometric loop. When $\theta = 90^\circ$, the signal exits port 2 and total destructive interference occurs at port 1.

The field applied to the MOFR is applied in the direction of propagation of the optical signal. In the absence of a field, no rotation is experienced by the optical signal. As a field is applied, favorably oriented domains (i.e., domains with their magnetic moments aligned with the applied field) will grow

^{a)}Author to whom correspondence should be addressed. Electronic mail: skemmet@iastate.edu

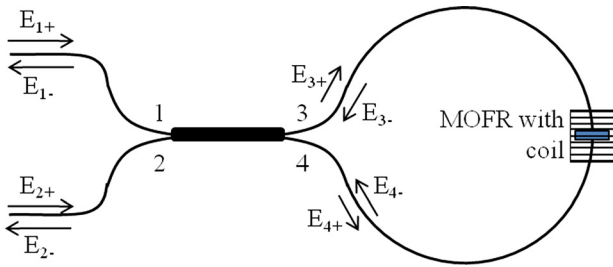

FIG. 1. (Color online) Sagnac switch with a magneto-optic Faraday rotator (MOFR) placed in the interferometric loop.

at the expense of unfavorably oriented domains, causing the rotation experienced by the optical signal to increase until the material is magnetized to its steady state value. The time it takes to reach this value is determined by the domain wall velocity, which has been well described for bismuth iron garnet.^{11,12} By initially overshooting the field necessary to achieve 90° rotation, the domain wall velocity can initially be higher, resulting in faster switching.

In order to achieve a prepulsed magnetic field through the MOFR, the circuit shown in Fig. 2 was designed. L₁ is an N-turn coil in which the MOFR is placed. The current through the coil is the sum of the currents through the amplifiers Q₁ and Q₂. The amplitude of the steady state field is determined by the amplitude of V_{p1} and the gain of the Q₁ amplifier. The amplitude of the prepulse portion of the total current is determined by the amplitude of V_{p2} and the gain of the Q₂ amplifier. The duration of the prepulse is controlled by the time constant associated with the input impedance of the prepulse amplifier. The major contributions to this impedance arise from the capacitive and resistive contributions from Q₂, D₂, C₂, and R₄ and the output impedance of the V_{p2} source.

If the thickness (T) of the MOFR is small compared to the length (l) of the coil, the magnetic field in free space inside the solenoid can be approximated as $H = NI/l$, where I is the current in the coil. The inductance of the coil with a cross-sectional area A is

$$L \approx \frac{\mu_0 N^2 A}{l} \quad (2)$$

The rise time dt can be found using $V = L(dI/dt)$, where V is the voltage over the coil. The sum of the currents in R2 and R3 will be approximately equal to the current in the coil and

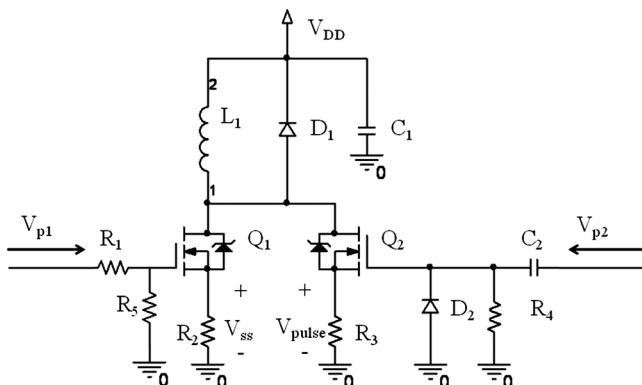

FIG. 2. Schematic of the prepulsed magnetic field driving circuit.

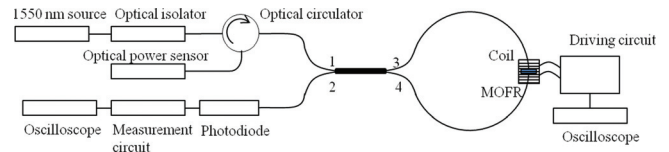

FIG. 3. (Color online) Schematic of the experimental setup.

can be used to calculate the magnetic field experienced by the MOFR.

The experimental setup shown in Fig. 3 was implemented, with the driving circuit being the circuit in Fig. 2. The MOFR used was a bismuth substituted iron garnet ($(\text{Bi}_{1.1}\text{Tb}_{1.9})\text{Fe}_{4.25}\text{Ga}_{0.75}\text{O}_{12}$) that measured $1 \text{ mm} \times 1 \text{ mm} \times 330 \mu\text{m}$ and had a saturation magnetization of 350 G. The input optical source was a 1550 nm laser, and all fibers used were single mode fibers. A 15 turn coil with a length of 5 mm was used. The following values were chosen for the prepulse circuit: $V_{DD} = 18 \text{ V}$, $R_1 = 0 \Omega$, $R_2 = R_3 = 1.2 \Omega$, $R_4 = R_5 = 100 \Omega$, and $C_1 = 10 \mu\text{F}$. V_{p1} , V_{p2} , and C_2 were varied. The optical output at port 2 was measured with a photodiode and a bipolar junction transistor (BJT) amplifier circuit. The voltage was measured over R₂ and R₃.

Figure 4 shows the effect of varying the steady magnetic field value while keeping the prepulse amplitude constant. Figure 4(a) shows the sum of the voltages measured over R₂ and R₃, from which the current and the magnetic field in the coil can be calculated (the values shown in the legend are for steady state values). The prepulse field had an amplitude of approximately 220 G, and the steady state values of the field within the coil were 65 G, 95 G, and 125 G, with optical rise times of 424 ns, 443 ns, and 418 ns, respectively. As expected, negligible change in rise time is observed, because the material experiences the same initial field. However, the settling characteristics of the optical signal change. In the cases of steady state magnetic field $B_{ss} = 65 \text{ G}$ and $B_{ss} = 95 \text{ G}$, the optical signal settles to less than half of its peak value, indicating that the necessary 90° Faraday rotation of the signal is not

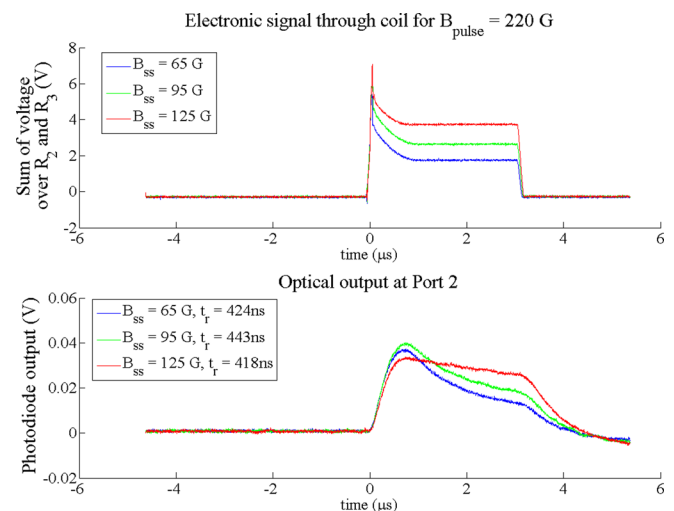

FIG. 4. (Color online) Experimental results for constant $B_{\text{pulse}} = 220 \text{ G}$ for varying steady state field (B_{ss}) values; (a) shows the sum of the signals measured over R₂ and R₃, and (b) shows the optical signal as measured with a photodiode.

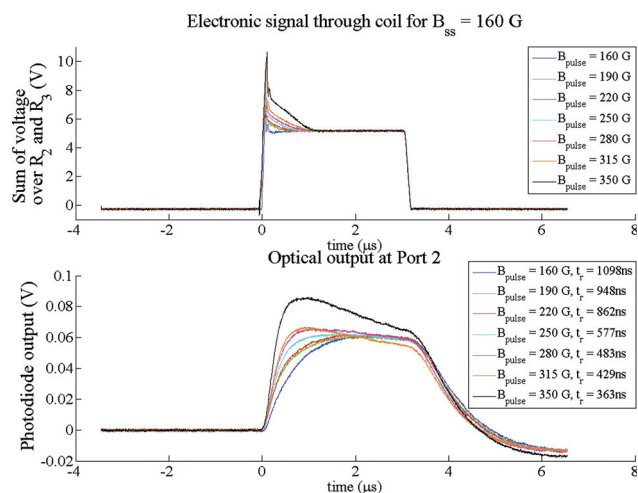

FIG. 5. (Color online) Experimental results for constant $B_{ss} = 160$ G for varying peak field (B_{pulse}) values; (a) shows the sum of the signals measured over R_2 and R_3 , and (b) shows the optical signal as measured with a photodiode.

achieved. When $B_{ss} = 125$ G, the optical signal settles to a much smaller degree, indicating that achieved Faraday rotation is much closer to the desired 90° .

Results for different magnetic pulse peak (B_{pulse}) values for the steady state magnetic field value $B_{ss} = 160$ G are shown in Fig. 5. Fig. 5(a) shows the sum of the signals over R_2 and R_3 (the values shown in the legend are for the peak magnetic field for each signal). As the amplitude of the prepulse increases, the rise time of the optical signal also increases. In the case where there is effectively no overshoot ($B_{pulse} = B_{ss} = 160$ G), the optical rise time is approximately $1.1 \mu s$. As is shown, as the amplitude of the overshoot increases, the rise time also increases. When the overshoot is equal to the saturation magnetization of the material ($B_{pulse} = 350$ G), the optical rise time is 363 ns; however, due to the short duration of the overshoot, the material does not saturate and cause undesirable domain pinning, as evidenced by the fact that the measured optical signal returns to an “off” state once the magnetic field is removed.

A final parameter that was varied was the duration of the overshoot, controlled by the overshoot decay time determined by value of C_2 , with a large value of C_2 corresponding to a longer overshoot duration. For overshoot value near the saturation field ($B_{pulse} = 350$ G), the following rise time corresponded to the values of C_2 : 254 ns with 3.3 nF, 232 ns with 4.7 nF, 215 ns with 6.8 nF, 195 ns for 8.2 nF, 220 ns for 12 nF, and 245 ns for 15 nF. The optical rise time decreases as the duration of the overshoot pulse increases, reaching a local minimum at $C_2 = 8.2$ nF. As C_2 is increased to a value greater than 8.2 nF, the rise time decreases. It was observed

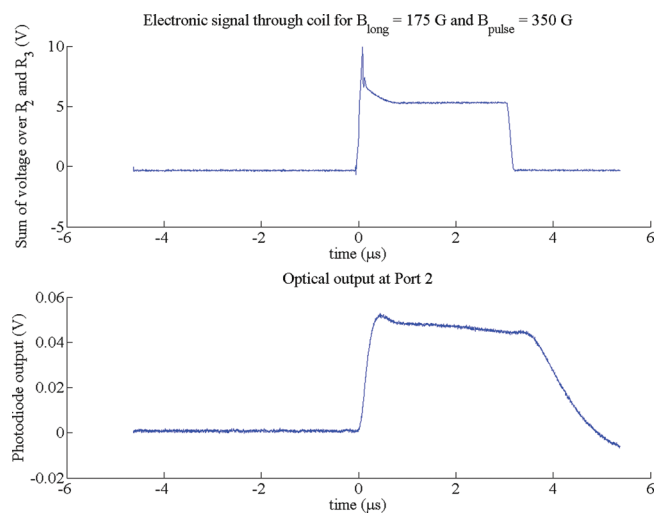

FIG. 6. (Color online) Experimental results demonstrating 200 ns switching; (a) shows the sum of the signals measured over R_2 and R_3 , and (b) shows the optical signal as measured with a photodiode.

that if the value of C_2 was 20 nF or greater, the optical output was extremely unstable, indicating that the sample may have been saturating. An optical rise time of 195 ns was achieved for $C_2 = 8.2$ nF. This result is shown in Fig. 6.

An MO switch capable of a switching time of 200 ns was presented. It was shown that a prepulsed magnetic field can greatly reduce the switching time, and the effect of different steady state and pulse amplitudes and overshoot durations was studied. It was shown that a magnetic field near the saturation field can be applied for short durations without saturating the material. The circuit for creating the prepulsed magnetic field was described.

ACKNOWLEDGMENTS

This material is based upon work supported under a National Science Foundation Graduate Research Fellowship.

- ¹N. A. Shalmany and A. Rahbar, “On the choice of all-optical switches for optical networking,” *High Capacity Optical Networks and Enabling Technologies, Proceedings*, (2007).
- ²J.-W. Tioh, M. Mina, and R. J. Weber, *IEEE Trans. Magn.* **46**, 2474 (2010).
- ³K. H. Chung *et al.*, *J. Appl. Phys.* **107**, 09A930 (2010).
- ⁴K. Shaoying *et al.*, *IEEE Trans. Magn.* **43**, 3656 (2007).
- ⁵S. Tkachuk *et al.*, *IEEE Trans. Magn.* **45**, 4238 (2009).
- ⁶S. Kemmet *et al.*, *J. Appl. Phys.* **105**, 07E702 (2009).
- ⁷S. Kemmet *et al.*, *IEEE Trans. Magn.* **46**, 1829 (2010).
- ⁸R. Bahuguna *et al.*, *IEEE Trans. Magn.* **43**, 2680 (2007).
- ⁹J. W. Tioh *et al.*, *IEEE Trans. Magn.* **44**, 3843 (2008).
- ¹⁰W. Qingping *et al.*, “A novel magneto-optic switch based on nanosecond pulse,” in *Communications and Photonics Conference and Exhibition, 2009. ACP 2009. Asia*, (2009), pp. 1–8.
- ¹¹V. Randoshkin and Y. Sazhin, *Phys. Solid State* **44**, 893 (2002).
- ¹²V. A. P. V. V. Randoshkin *et al.*, *Phys. Solid State* **45**, 503 (2003).