

ULTRASONIC DETERMINATION OF GRAIN SIZE IN URANIUM

William D. Brosey

Union Carbide Corporation, Nuclear Division
Oak Ridge Y-12 Plant*
Post Office Box Y
Oak Ridge, Tennessee 37830

SUMMARY

An ultrasonic technique has been developed that enables the measurement of grain size in uranium without metallographic preparation or destructive analysis. Pitch-catch ultrasonic analysis using transverse (shear) waves was conducted in the determination of grain size in wrought uranium parts.

INTRODUCTION

Mechanical properties associated with particular grain sizes in wrought uranium parts have become desirable in several instances. Measuring the grain size has traditionally been accomplished through metallographic techniques. One such method is to section the part at a representative location, then polish, etch, and photograph the specimen. Another method commonly used is to polish and etch the surface of the part to obtain a surface measurement of grain size. The major disadvantage of these techniques is the inability to account for possible variation in the grain size through the thickness or over the surface of the part. Often when parts are formed, a banded structure occurs in which the inner grains are a different size from the outer grains. The grain structure also varies with the amount of work applied to each portion of the part. To account for these possible differences metallographically, parts would have to be sectioned at several locations along the contour, effectively destroying the

* Operated for the U.S. Department of Energy by Union Carbide Corporation, Nuclear Division, under Contract W-7405-eng-26.

part. One possible solution that has been used is to make several identical parts and section one as a representative sample. This approach is extremely expensive. Moreover, it has been observed that parts formed and heat treated by supposedly identical procedures do not necessarily have identical grain structure. This creates a requirement to test each part for grain size; therefore, a nondestructive testing technique for measuring grain size is needed.

An ultrasonic nondestructive testing technique has been developed at the Oak Ridge Y-12 Plant that takes an average grain size measurement through the thickness of the part. This makes it possible to account more accurately for variable grain structure within the part. Ultrasonic grain size determination is based on the frequency dependent scattering of sound by grains of various diameter.

THEORY

The theory for ultrasonic grain size evaluation has been explored in some detail.¹ The functional relationship of frequency and grain diameter to attenuation of an ultrasonic signal has been shown to vary as the ratio of wavelength to grain diameter changes.² In uranium, it was found that at approximately $\lambda \leq 3 \bar{D}$ (where λ is wavelength and \bar{D} is average grain diameter), the sound was completely attenuated by scattering in the material.³ Ultrasonic grain size measurement techniques are based on the principle that, as the wavelength of an ultrasonic signal becomes of the same order of size as the grains in its path, the sound is strongly scattered, greatly attenuating the signal.⁴ Therefore, the larger the grain size present in a part, the lower the frequency of sound that will pass through the part relatively unscattered. This has been presented graphically in Figure 1.

In the present procedure for measuring grain size ultrasonically, the frequency of sound attenuated by wrought uranium was determined by performing a fast fourier transform (FFT) on the ultrasonic signal. The high frequency edge of the FFT curve was considered to be the frequency cutoff point which was then related to grain size. As shown in Figure 2, the frequency cutoff point was calculated by finding the midpoint between the peak value and the lowest value of the high frequency edge of the FFT.

Grain size values used in the performance of the test were listed in ASTM grain size number. The formula used to determine ASTM grain size number is $n=2^{N-1}$ where n is the number of grains per square inch in a 100X photograph and N is the grain size number. This formula was used in establishing the grain size

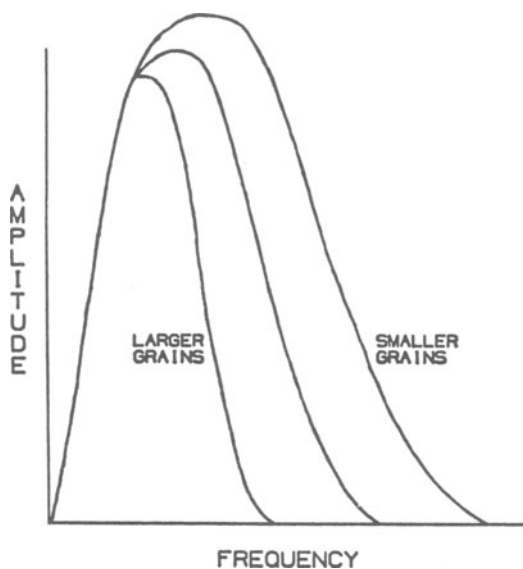

Fig. 1. Decreased grain size leads to increased cutoff frequency.

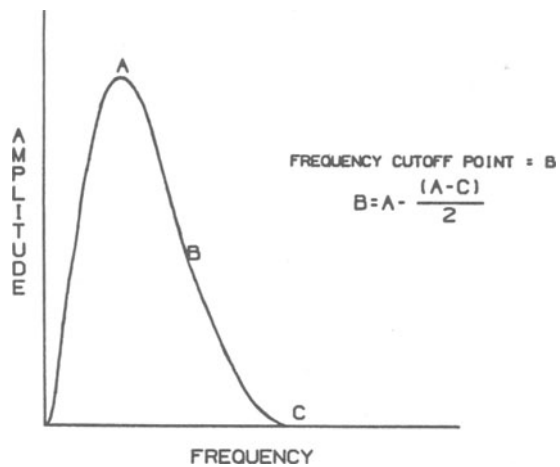

Fig. 2. Frequency cutoff determination.

values on the ASTM standard designation chart E-112 Plate No. 1 which was used in determining the grain size of wrought uranium.

EXPERIMENTAL METHOD

The ultrasonic method used to measure grain size in this test was pitch-catch. In this method, one transducer is used to transmit the signal while another transducer catches the signal after it has reflected off the back of the part. This configuration is shown in Figure 3. The longitudinal ultrasonic signal is mode converted to a 45-degree transverse (shear) wave in the part. A shear wave inspection has several advantages over a longitudinal (compression) wave inspection. It has been found that shear waves have more sensitivity to possible grain orientation, and are more sensitive to a few larger grains located in the part. This extra sensitivity in a shear inspection was found to be caused by the ultrasonic waves incident on the grains being split into both longitudinal and transverse components by scattering.^{5,6} Depending on the incident wave type, the energy in each scattered component of the wave is different. It was demonstrated that the recovered energy from incident shear waves was much greater than for incident longitudinal waves in the same material. Another advantage was that frequency response over a wider range of grain sizes could be measured using a single type of broad band transducer. In a wrought uranium longitudinal inspection, the wavelength is approximately 1.7 times what it is in a shear inspection for a given frequency which corresponds to a higher frequency cutoff for a given grain size. Only those grain sizes which have a cutoff

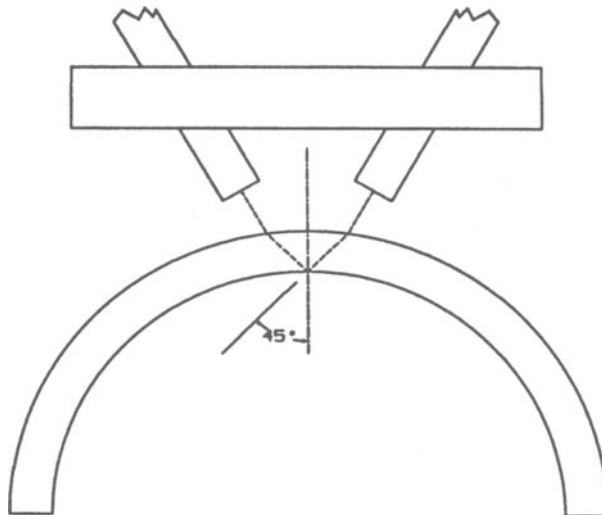

Fig. 3. Pitch-catch grain size measurement of uranium parts.

frequency within the bandwidth of the transducer can be measured. Therefore, to cover a range of grain sizes, the transducer bandwidth must be broader for a longitudinal inspection than for a shear inspection. In Figure 4, a representation of transducer bandwidth is shown. Grain sizes with a cutoff frequency less than the low frequency edge, or greater than the high frequency edge, cannot be measured. Part geometry also made the pitch-catch technique desirable since it allowed the transducers to remain on one side of the curved part.

Other ultrasonic methods that have been explored include through transmission and contact shear. Through transmission as a longitudinal ultrasonic analysis technique did not allow as broad a grain size spectrum to be measured using a single transducer type, and was less sensitive to a small percentage of larger grains in the uranium. Contact shear worked well on flat uranium coupons; however, on curved parts, the viscous couplant attenuated the sound inconsistently due to varying couplant depths across the face of the transducer. Metal foil couplants were tried in an effort to improve couplant consistency. Although a significant increase in high frequency was observed when measuring flat coupons, the metal foils did not couple well to curved parts. The pitch-catch technique combined the best of these two methods by using a constant water couplant along with the advantages of a shear analysis.

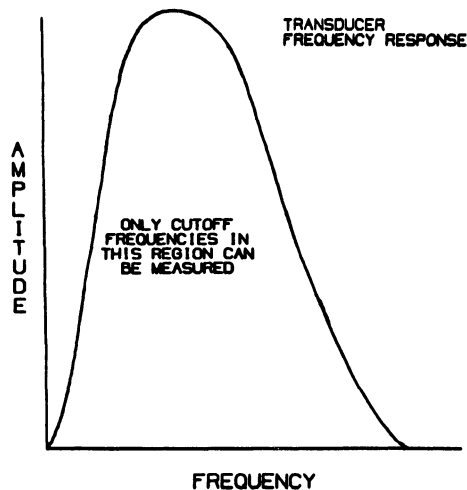

Fig. 4. Grain size detection is limited by transducer frequency bandwidth.

Flat coupons between 0.635 and 2.54 centimeters thick of uranium were measured for possible variations in frequency response. Thickness effects on frequency response were determined to be minimal for grain sizes smaller than ASTM #2. Grain sizes larger than ASTM #2 were found to have a decreasing frequency response, with respect to sample thickness, which leveled out for the thicker coupons. One possible explanation for this is that the sound has been scattered by fewer grain boundaries in the larger grained coupons, allowing more high frequency sound to pass through the thinner coupons. It was determined that thickness effects in the region of interest of the test which included grain sizes between ASTM #2 and ASTM #6 were negligible. A plot of cutoff frequency vs coupon thickness for two grain sizes is shown in Figure 5.

The frequency response was found to vary significantly between transducer pairs, making it necessary to calibrate each transducer pair with a set of standards. Transducers with different frequency bandwidth were found to produce different frequency cutoff data when measuring grain size. It was found that 7.5 MHz transducers produced significantly different values from 10 MHz transducers when measuring the same grain size standard. This is demonstrated in Table 1. Different transducer pairs of the same

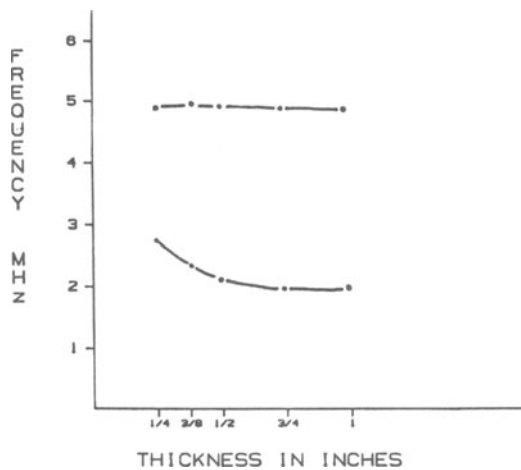

Fig. 5. Cutoff frequency vs thickness for flat coupons.

Table 1. Frequency Variations at Different Grain Sizes for 7.5 and 10 MHz Transducers

Part Location	Grain Size ASTM #6 Transducer Type		Grain Size ASTM #4 1/2 Transducer Type	
	7.5	10	7.5	10
1	6.3	6.8	5.3	5.3
2	4.5	6.8	3.6	4.8
3	4.7	5.1	4.0	4.0

frequency type were also found to differ in frequency response. One possible explanation of this is that different transducers produce a different energy spectrum which could cause the signal amplitude at a given frequency to appear more attenuated for one transducer than for another.

Part curvature also affected the frequency response, but not as dramatically. The effect of curvature, which was more pronounced for smaller grain sizes, caused the frequency cutoff value to increase as the curvature of the part increased. This effect was observed by placing the same transducer pair at different part locations.

EXPERIMENTAL CONFIGURATION

The experimental configuration is shown in Figure 6. In this setup, a Philips PM 3310 60 MHz digitizing oscilloscope and a transducer multiplexer were interfaced with an LSI 11/23 micro-computer. A Panametrics 5055 PR pulser/receiver and Panametrics V 320 7.5 MHz transducer were used in obtaining the signals sent to the oscilloscope.

Each of several pairs of transducers were mounted in a rigid aluminum bar at a fixed angle that caused 45-degree shear waves to pass through the part. The transducer pair has three degrees of freedom which include in and out, side to side, and up and down motion. Motion is provided by a Testech minimanipulator and Gilman slide. This allowed the signal to be peaked up on the back surface of the part. Once the pairs of transducers had been set up for a particular part type, they needed very little further adjustment. Each transducer search tube was fitted with a brass collar that fixed the water path of the signal. The water path was

EXPERIMENTAL CONFIGURATIONS

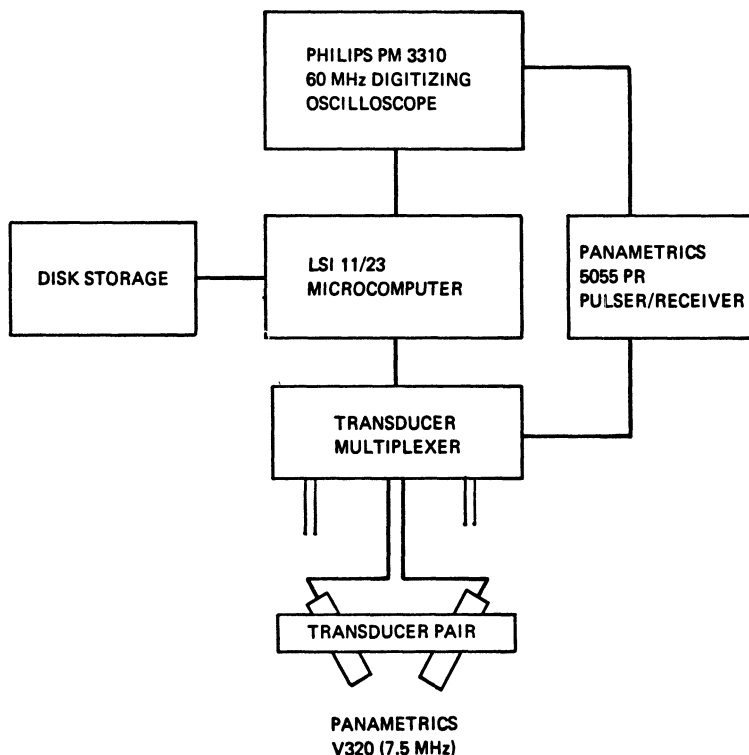

Fig. 6. Experimental configuration.

set so that each signal peaked up at the same time delay on the oscilloscope within the tolerance of part thickness variability.

In an effort to reduce as many variables as possible, standards were made which closely resembled parts. Plugs of uranium containing the desired range of grain sizes were press fitted into an aluminum representation of a part. The standard was then contoured to part specifications. Grain sizes of each plug were determined by comparison with ASTM Designation Chart E-112 Plate No. 1 and by the circle method ASTM Designation E-112-74 section 11.3. For the grain size determination test, standards containing three different grain sizes, ASTM #00, ASTM #4 1/2, and ASTM #6 were evaluated to establish a curve on which to place part data. Micrographs of these grain sizes are displayed in Figure 7. When a part was run, its frequency response was fit to the curve which established a grain size value for that measurement.

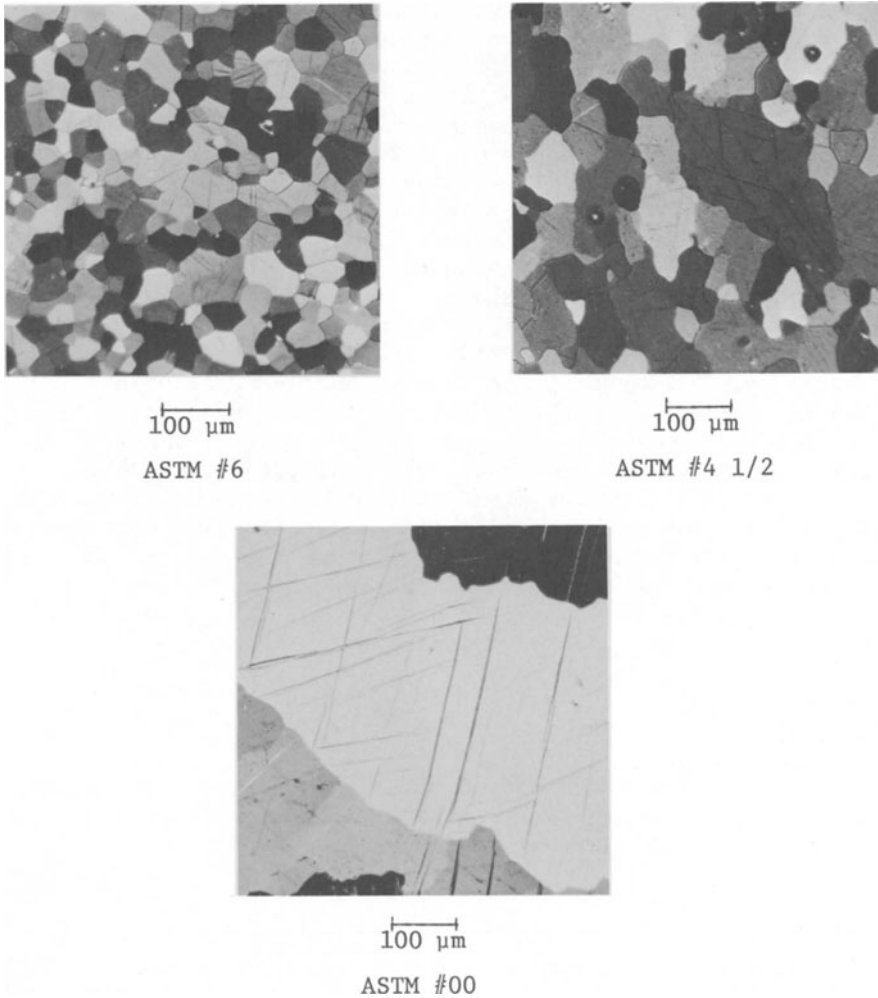

Fig. 7. Grain size micrographs from grain size standard.

EXPERIMENTAL PROCEDURE

Except for peaking up the signal on the back surface of the part, loading, and unloading the part, the test was computer-controlled with minor operation interaction. Each of the transducer pairs were multiplexed with the computer so that the signal from only one pair was displayed at any one time. The computer pulsed each pair of transducers consecutively to obtain a grain size measurement at each location. When a signal was displayed on the oscilloscope, the operator was given the opportunity to peak up

the waveform. Eight digital waveforms were transferred from the scope to the computer where they were averaged. The transducers were turned off and eight base waveforms were transferred to the computer and averaged. The resulting base signal was then subtracted from the resulting waveform signal. The combined result was windowed to isolate the waveform from the rest of the signal. Windowing was accomplished by setting all points in the digitized signal to zero, except for those points making up the waveform. Figure 8 demonstrates the difference between a windowed and unwindowed waveform. By isolating the waveform, a much smoother and more accurate FFT was obtained. The operator was allowed the opportunity to extend or contract the window if necessary to isolate the waveform more exactly. The FFT of the waveform was calculated and displayed on the scope. Another subroutine calculated the frequency cutoff value. At this point, the test differs between a standard and part measurement. For a standard measurement, the cutoff frequency value was used to establish a grain size vs frequency curve. In a part measurement, the cutoff frequency value was compared with the grain size vs frequency curve produced with the standard. A grain size measurement on the part could then be obtained. After all measurements on a part have been made, a testing report is printed out listing the grain sizes relative to their location on the part.

CONCLUSIONS

Using the pitch-catch method of ultrasonic analysis, it was possible to determine the grain size of a uranium part to within ± 1 ASTM grain size number with a 2σ accuracy. The slope of the

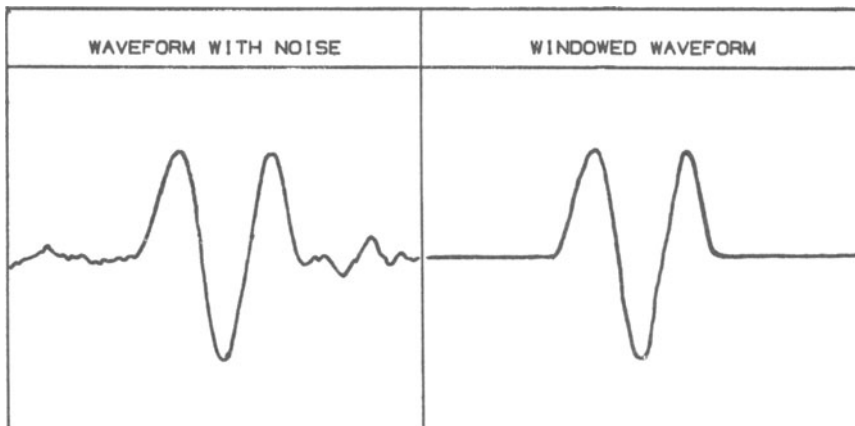

Fig. 8. Waveform windowing produces a cleaner signal.

frequency vs grain size curve was found to vary slightly between part locations. This difference in slope was most likely caused by a combination of part curvature and transducer difference. Figure 9 displays the frequency vs grain size curve for three different part locations.

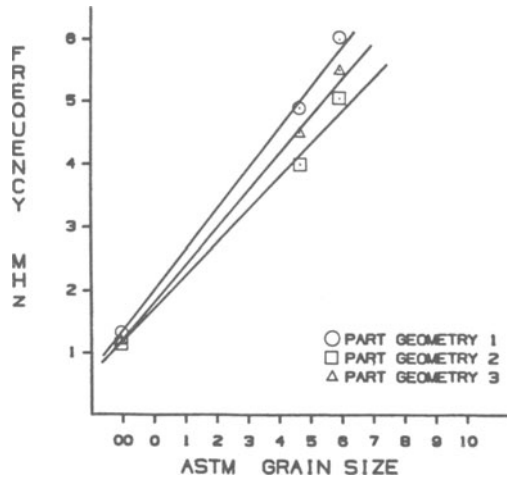

Fig. 9. Cutoff frequency vs grain size.

REFERENCES

1. E. P. Papadakis, "Scattering in Polycrystalline Media", Methods of Experimental Physics, Vol. 19, 237-298 (1981).
2. E. P. Papadakis, "Revised Grain-Scattering Formulas and Tables", The Journal of the Acoustical Society of America, Vol. 37, No. 4 (April 1965).
3. H. L. Dunegan, "Grain Size Measurements in Uranium by Use of Ultrasonics, UCRL-6984 (July 2, 1962).
4. E. P. Papadakis, "Ultrasonic Attenuation Caused by Scattering in Polycrystalline Metals", The Journal of the Acoustical Society of America", Vol. 37, No. 4 (April 1965).
5. J. Szilard, G. Scruton, "Revealing the Grain Structure of Metals by Ultrasonics", Ultrasonics (May 1973).
6. I. Bihari, J. Szilard, "Ultrasonic Testing of Inhomogeneities in Heterogeneous Media", Periodica Polytechnica, II (1967).