

2008

# A Quality Assurance Project Plan for Monitoring Gaseous and Particulate Matter Emissions from Broiler Housing (Appendix D)

Lara B. Moody  
*Iowa State University*

Hong Li  
*Iowa State University*

Robert T. Burns  
*Iowa State University*

Hongwei Xin  
*Iowa State University, hxin@iastate.edu*

Richard S. Gates  
*University of Kentucky*

Follow this and additional works at: [http://lib.dr.iastate.edu/abe\\_eng\\_pubs](http://lib.dr.iastate.edu/abe_eng_pubs)

 *next page for additional authors*  
Part of the [Agriculture Commons](#), and the [Bioresource and Agricultural Engineering Commons](#)

The complete bibliographic information for this item can be found at [http://lib.dr.iastate.edu/abe\\_eng\\_pubs/248](http://lib.dr.iastate.edu/abe_eng_pubs/248). For information on how to cite this item, please visit <http://lib.dr.iastate.edu/howtocite.html>.

---

# A Quality Assurance Project Plan for Monitoring Gaseous and Particulate Matter Emissions from Broiler Housing (Appendix D)

## **Abstract**

Section Title: Appendix D: SOP of INNOVA 1412 Photoacoustic Multi-Gas Monitor--Description and Principle of Operation; Appendix E: SOP of Temperature and Humidity Measurement Temperature Measurements.

## **Keywords**

Quality Assurance, Emission, Broiler Housing, Particulate Matter, PM2.5, PM10

## **Disciplines**

Agriculture | Bioresource and Agricultural Engineering

## **Comments**

Published in *A Quality Assurance Project Plan for Monitoring Gaseous and Particulate Matter from Broiler Housing* (St. Joseph, MI: ASABE, 2008).

## **Authors**

Lara B. Moody, Hong Li, Robert T. Burns, Hongwei Xin, Richard S. Gates, Steven J. Hoff, and Douglas G. Overhults

## Appendix D: SOP of INNOVA 1412 Photoacoustic Multi-Gas Monitor

### Description and Principle of Operation

The photoacoustic multi-gas monitor (INNOVA 1412, Innova AirTech Instruments, Denmark) is a highly accurate, reliable and stable quantitative gas monitoring system. It uses a measurement system based on the photoacoustic infra-red detection method, and is capable of measuring almost any gas that absorbs infra-red light. Gas selectivity is achieved through the use of optical filters. By installing up to five of these filters in the 1412, it can measure the concentration of up to 5 component gases and water vapour in any air sample. Although the detection limit is gas dependent, it is typically in the parts per billion (ppb) region. The accuracy of these measurements is ensured by the 1412's ability to compensate for temperature and pressure fluctuations, water vapour interference and interference from other gases known to be present. Reliability of measurement results can be ensured by regular self-tests, which the 1412 performs.

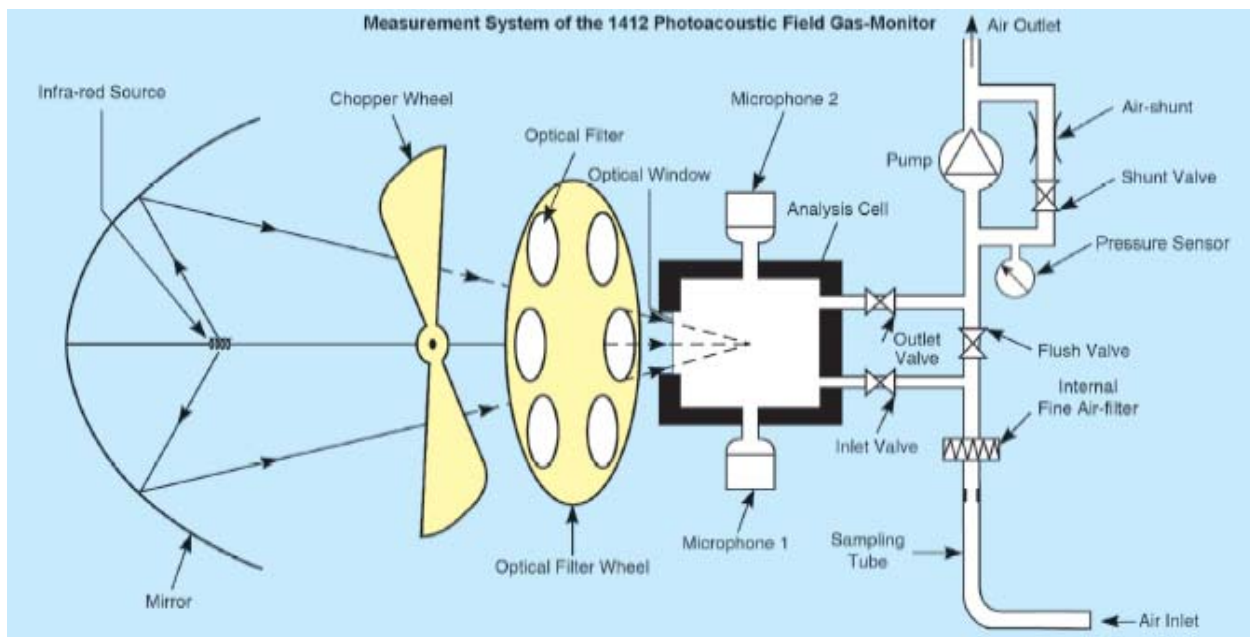

Figure D.1. Measurement system of the 1412.

An interior pump draws air from the sampling point through the air-filter to flush out the “old” air in the measurement system and replace it with a “new” air sample. The “new” air sample is hermetically sealed in the analysis cell by closing the inlet and outlet valves (Figure D.1). Light from an infra-red light source is reflected off a mirror, passed through a mechanical chopper, which pulsates it, and then through one of the optical filters in the filter wheel. The gas being monitored selectively absorbs the light transmitted by the optical filter, causing the temperature of the gas to increase. Because the light is pulsating, the gas temperature increases and decreases causing an equivalent increase and decrease in the pressure of the gas (an acoustic signal) in the closed cell. Two microphones mounted in the cell wall measure this acoustic signal, which is directly proportional to the concentration of the monitored gas present in the cell. The filter

wheel turns so that light is transmitted through the next optical filter, and the new signal is measured. The number of times this is repeated is dependent upon the number of gases being measured. The response time is down to approximately 13 seconds for one gas or water vapour, or approximately 40 seconds if five gases and water vapour are measured. The  $\text{NH}_3$ 's full scale is adjustable up to 2000 ppm. It has a lower detectable limit of 60 ppb.

The INNOVA 1412 multi-gas analyzer is specified with a 1-second sampling integration time and fixed flushing time; 2 seconds for the chamber and 3 seconds for the tubing; and the response time for one single sampling cycle with  $\text{NH}_3$ , carbon dioxide and dew-point temperature measurements is approximately 22 seconds. The response time of the analyzer to step changes in gas concentrations was tested (Figure D.2). The analyzer was challenged with two  $\text{NH}_3$  calibration span gases, 22.8 ppm and 60.8  $\text{NH}_3$  respectively in a  $\text{N}_2$  balance ( $\pm 2\%$  accuracy) (Matheson Gas Products, Inc., Montgomeryville, PA) at flow rates of 8 L/min through two 80 ft long individual sampling lines. At the beginning of the test, the two sampling lines were full of  $\text{N}_2$  gas. During the first two sampling cycles, the time taken for the readings to change from 0 ppm ( $\text{N}_2$  gas) to 22.8 ppm was 10 cycles (220 seconds), and the time taken for the readings to change from 22.8 ppm (span gas) to 60.8 ppm was also 10 cycles (220 seconds). After the first two span gas changes, the time taken for the readings to change from 22.8 to 60.8 ppm or from 60.8 to 22.8 ppm within  $\pm 2\%$  difference was 4 cycles (88 seconds). The reason 10 cycles is required for the initial two changes is to purge the  $\text{N}_2$  gas in the sampling lines. Once the sampling lines are full of the span gases, the  $\text{NH}_3$  analyzer had a faster response time. It implied that separate sampling line should be used for each sampling location and air sample should be drawn continuously. Similarly, the time taken for the readings to change from 22.8 ppm to zero air was greater than 10 cycles when sampling lines were purged by zero gas. Thus, the results indicated that an 88-second sampling time (4 cycles) for the  $\text{NH}_3$  analyzer would be sufficient to achieve 97% or better of the concentration value.

INNOVA 1412 setup: 22 sec/sample (Chamber flush: 2 s; Tube flush: 3s; S.I.T.: 1 s)

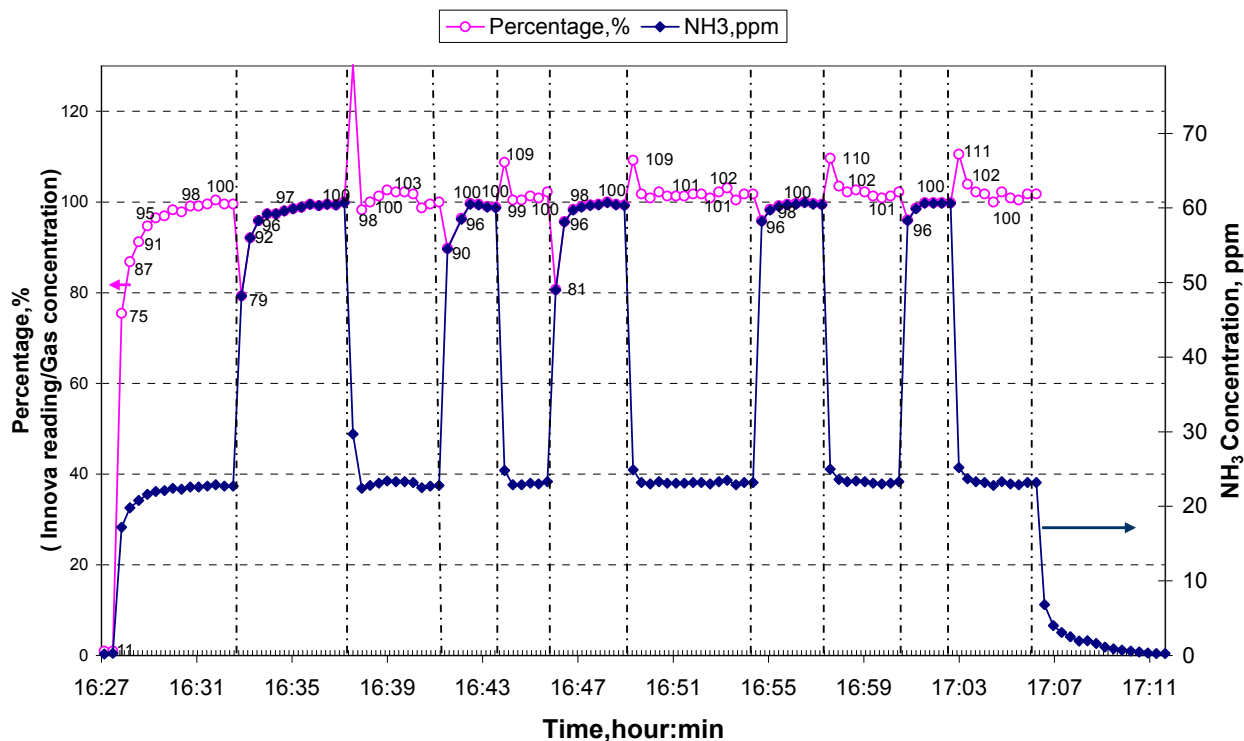

Figure D.2. Response of INNOVA 1412 intermittent exposure of 22.8, 60.8 ppm NH<sub>3</sub> (N<sub>2</sub> balance) and ambient air.

## Calibration

### Warming Up the Monitor

The infra-red light source is very hot so the temperature in the analysis cell increases as calibration measurements proceed. Conditions within the cell tend to stabilize more quickly once the temperature inside the analysis cell is 15°C above the ambient room temperature. A period of 30-40 minutes is suggested to warm up the analysis cell before a calibration task is started. This will reduce the time required for calibration.

### The Basic Calibration Setup

The general equipment required to perform the calibration is shown in Figure D.3. All the solenoid valves around the manifold (M1) will close using the manual control in the LabView 7 program. The tubing from the cal-gas cylinder will be connected to the flow meter which is mounted on the side of the instrument rack and connected to the sampling manifold (M2).

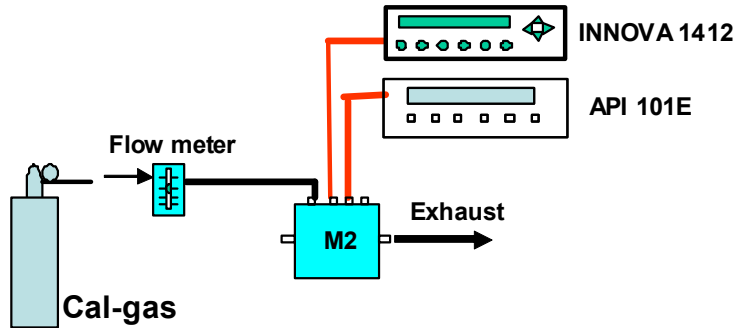

Figure D.3. General equipment required for a calibration task

**Producing a Supply of Clean, Wet Air**

Bubble zero-gas through a thermostatically controlled water-bath to produce a supply of clean, wet air to the Monitor during humidity interference calibration of the filters (see Figure D.4). The temperature of the water bath should be at least 2°C below the ambient temperature of the room where calibration is to be performed.

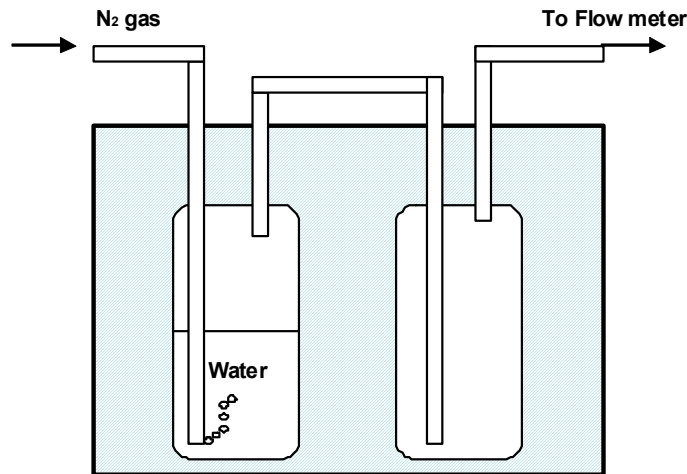

Figure D.4. Schematic diagram of the equipment necessary to produce a supply of clean, wet air.

**Setting the Communication Parameters**

The communication parameters necessary for the monitor to communicate with the Gas Monitoring Software 7304 are shown below:

Baud rate	9600
Stop bits	1
data bits	7
Parity	Even
Hardwire mode	Leased line
Handshake type	Hardwire

To prevent communication errors, the text line terminator, print data log and print error log must be set as shown below:

Text line Terminator	CR-LF
Print Data Log	<b>NO</b>
Print Error Log	NO

**Setup**→ **CONFIGURATION**→**System**→**General**→**Test**→ **Self test**→**Yes**→**Print Data Log**→**NO**→**Print Error Log**→**NO**

### Calibration Gases

Zero air, CO<sub>2</sub> in N<sub>2</sub> and NH<sub>3</sub> in N<sub>2</sub> are used to calibrate the instrument. The certified calibration gases will consist of zero air (99.999% accuracy, Acid Rain CEM zero), CH<sub>4</sub> in N<sub>2</sub> (NIST traceable, EPA Protocol, ±1% accuracy), Propane in N<sub>2</sub> (NIST traceable, EPA Protocol, ±1% accuracy), CO<sub>2</sub> in N<sub>2</sub> (NIST traceable, EPA Protocol, ±1% accuracy), NH<sub>3</sub> in air or nitrogen (manufactory standard, certified plus grade, ±2% accuracy).

### Zero and Span Calibration Procedure for Analyzer Only

- Change the setting of 1412 communication parameters.
- Turn off the 1412 and disconnect 1412 with the Compact Fieldpoint module.
- Reconnect the 1412 to the COM1 port of the PC.
- Turn on the 1412.
- Open the Calibration program and create a new calibration task.
- Detach the air inlet tube from the existing sampling manifold. Close the pipe adapter of the sampling manifold with a cap or plug.
- Attach the 1412 to a calibration manifold.

### Zero (N<sub>2</sub>) Gas Calibration

1. Open the Calibration program and create a **New** task.

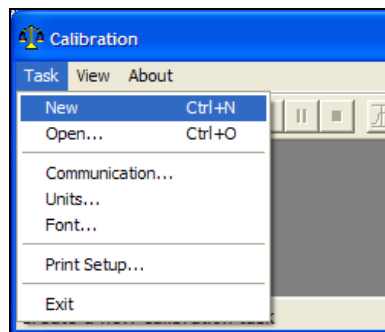

2. Type in the desired task name (TYSON ##\_MMDDYYYY) and click OK.
3. Pull down the **Sequence** menu. Click **Settings**.

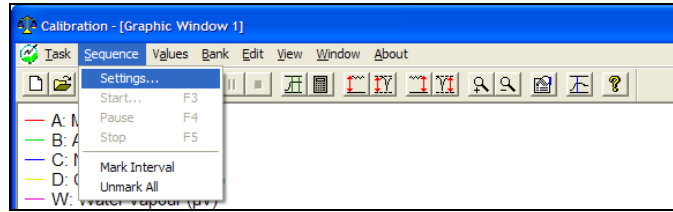

4. Click on the Calibration index-card, if it is not already at the front.

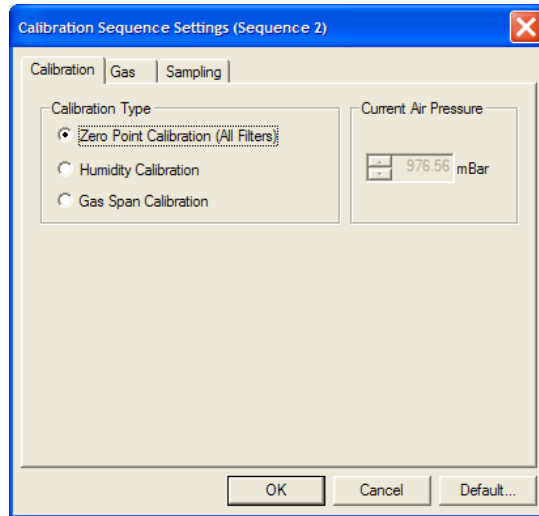

5. Click to select **Zero** point radio-button.

6. Click on the Gas index-card and click in the Sample Integration Time field, and select the desired time: 5 s for Ammonia, 1 s for CO<sub>2</sub>, 1 s for Nitrous oxide (N<sub>2</sub>O), 1 s for propane and 5 s for CH<sub>4</sub>.

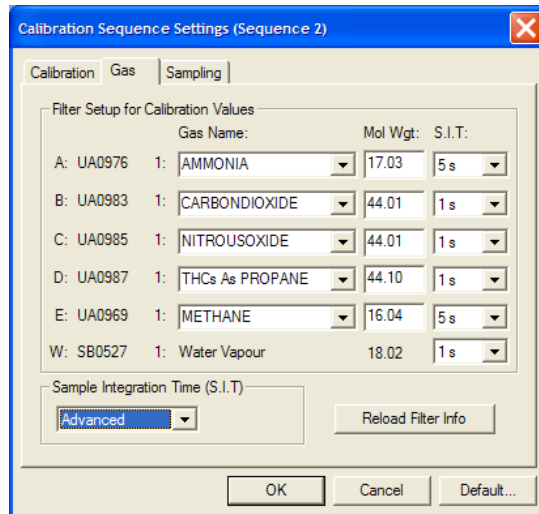

7. Click on the Sampling index-card and set the flushing time to desired time: Fixed time, 2 s for Chamber and 3 s for Tube.



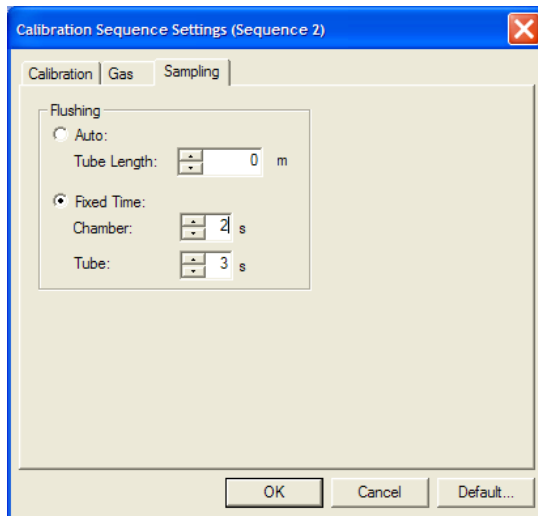

8. When all the settings are correct, click on **OK**.
9. Pull down the **Sequence** menu and click on **Start**.

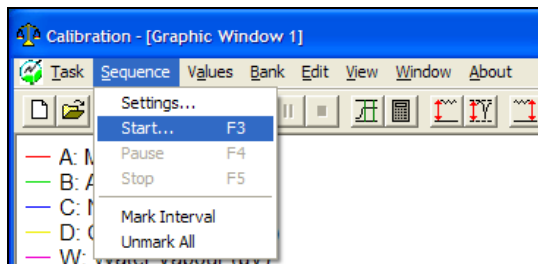

10. Insert the 1/4" ID tubing (from N<sub>2</sub> gas regulator) to the flow meter mounted on the side of the instrument rack; then open the regulator valve to allow gas flow. Zero gas is now flowing from the cylinder to the 1412.
11. Adjust regulator valve until vent airflow is about 2.5 L/min (read from bottom of ball of the flow meter mentioned above). This provides a little extra zero air to the 1412 and keeps the pressure inside the manifold close to the atmospheric pressure.
12. Record time and analyzer display in lab notebook.
13. Continuously inject the gas for 5 min after display is stabilized.
14. Pull down the **Sequence** menu and click on **Stop**.
15. Close regulator and remove Zero gas tubing.

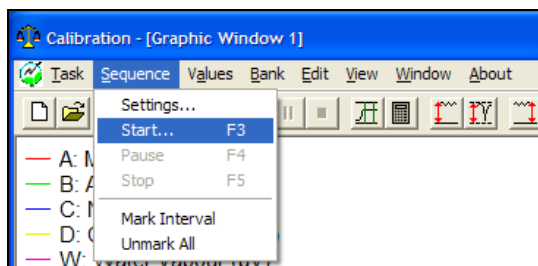

### Humidity Calibration

1. Pull down the Sequence menu. Click Settings.
2. Click on the Calibration index-card, if it is not already at the front.
3. Click to select Humidity Calibration.

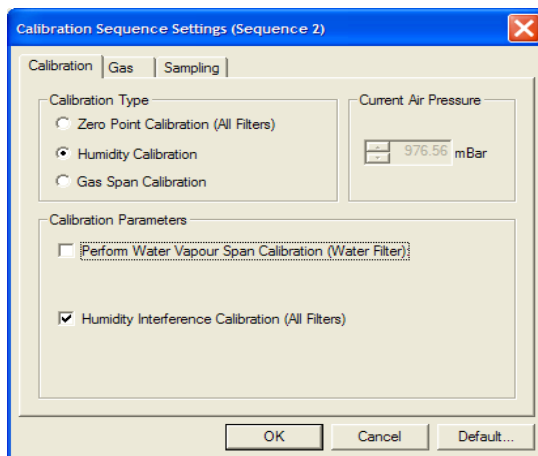

4. Only Select “Humidity Interference Calibration (All Filters)”. Do not select “Perform Water Vapor Span Calibration”.
5. Click on the Gas index-card and click in the Sample Integration Time field, and select the desired time as above.
6. When all the settings are correct, click on OK.
7. Pull down the Sequence menu and click on Start.
8. Connect a water bath device between the zero gas regulator and the flow meter mounted on the side of the instrument rack; then open the regulator valve to allow gas flow. Zero gas is now flowing from the cylinder to the 1412.
9. Adjust regulator valve until vent airflow is about 2.5 L/min (read from bottom of ball of the flow meter mentioned above). This provides a little extra zero air to the 1412 and keeps the pressure inside the manifold close to the atmospheric pressure.
10. Record time and analyzer display in lab notebook.
11. Continuously inject the gas for 5 min after display is stabilized.
12. Pull down the Sequence menu and click on Stop.
13. Close regulator and main valve and remove zero gas tubing.

### Span Gas Calibration (NH<sub>3</sub>)

1. Pull down the **Sequence** menu. Click **Settings**.

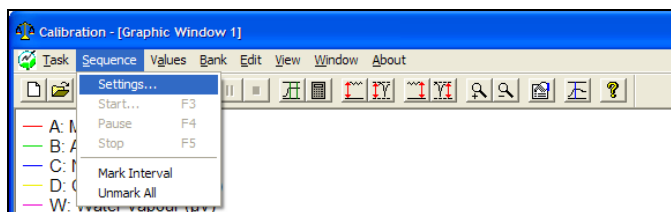

2. Click on the Calibration index-card, if it is not already at the front.

3. Click to select **Gas Span Calibration** radio-button.

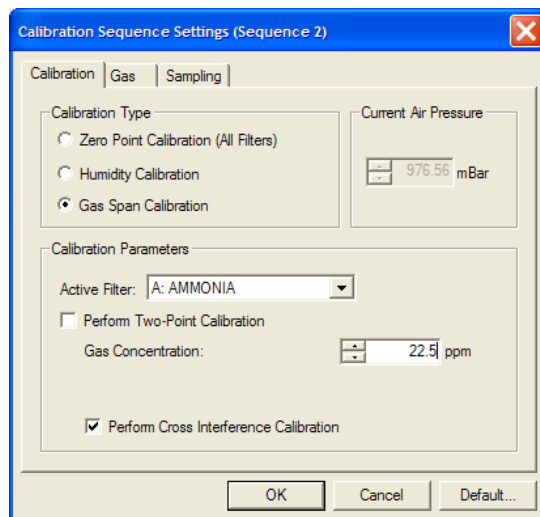

4. Click in the Active filter field Ammonia and select the **Ammonia**, and check **Perform Cross Interference Calibration** and input the concentration of NH<sub>3</sub> gas.
5. Click on the Gas index-card and click in the Sample Integration Time field, and select the desired time as above.
6. When all the settings are correct, click on **OK**.
7. Pull down the **Sequence** menu and click on **Start**.
8. Insert the 1/4" ID tubing (from the NH<sub>3</sub> gas cylinder) to the flow meter mounted on the side of the instrument rack; then open the regulator valve to allow gas flow. NH<sub>3</sub> gas is now flowing from the cylinder to the 1412.
9. Adjust regulator valve until vent airflow is about 2.5 L/min (read from bottom of ball of the flow meter mentioned above). This provides a little extra gas to the 1412 and keeps the pressure inside the manifold close to the atmospheric pressure.
10. Record time and analyzer display in lab notebook.
11. Continuously inject the gas for 5 min after display is stabilized.
12. Pull down the **Sequence** menu and click on **Stop**.
13. Close regulator and main valve and remove tubing from the NH<sub>3</sub> gas cylinder.

#### Span Gas Calibration (CO<sub>2</sub>)

1. Pull down the **Sequence** menu. Click **Settings**.
2. Click on the Calibration index-card, if it is not already at the front.
3. Click to select **Gas Span Calibration** radio-button.
4. Click in the Active filter field Ammonia and select the **Carbon Dioxide**, and check **Perform Cross Interference Calibration** and input the concentration of CO<sub>2</sub> gas.

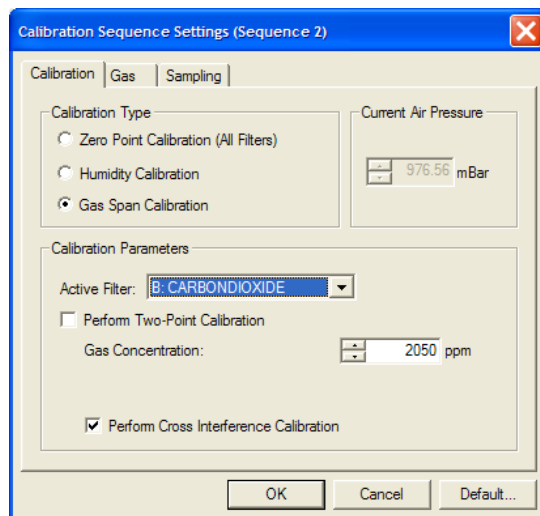

5. Click on the Gas index-card and click in the Sample Integration Time field, and select the desired time.
6. When all the settings are correct, click on **OK**.
7. Pull down the **Sequence** menu and click on **Start**.
8. Connect the 1/4" ID tubing (from the CO<sub>2</sub> gas cylinder) with a Nafion tubing, and then connect to the manifold; then open the regulator valve to allow gas flow. CO<sub>2</sub> gas is now flowing from the cylinder to the 1412.
9. Adjust regulator valve until vent airflow is about 2.5 L/min (read from bottom of ball of the flow meter mentioned above). This provides a little extra gas to the 1412 and keeps the pressure inside the manifold close to the atmospheric pressure.
10. Record time and analyzer display in lab notebook.
11. Continuously inject the gas for 5 min after display is stabilized.
12. Pull down the **Sequence** menu and click on **Stop**.
13. Close regulator and main valve and remove tubing from the CO<sub>2</sub> gas cylinder.

#### Span Gas Calibration (Propane)

1. Pull down the **Sequence** menu. Click **Settings**.
2. Click on the Calibration index-card, if it is not already at the front.
3. Click to select Gas Span Calibration radio-button.
4. Click in the Active filter field Ammonia and select the **THC (propane)**, and check **Perform Cross Interference Calibration** and input the concentration of Propane gas.

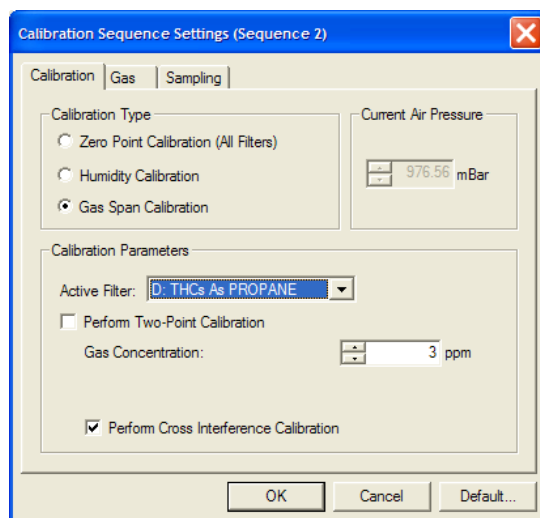

5. Click on the Gas index-card and click in the Sample Integration Time field, and select the desired time.
6. When all the settings are correct, click on **OK**.
7. Pull down the **Sequence** menu and click on **Start**.
8. Connect the 1/4" ID tubing (from the Propane gas cylinder) to the flow meter mounted on the side of the instrument rack; then open the regulator valve to allow gas flow. Propane gas is now flowing from the cylinder to the 1412.
9. Adjust regulator valve until vent airflow is about 2.5 L/min (read from bottom of ball of the flow meter mentioned above). This provides a little extra gas to the 1412 and keeps the pressure inside the manifold close to the atmospheric pressure.
10. Record time and analyzer display in lab notebook.
11. Continuously inject the gas for 5 min after display is stabilized.
12. Pull down the **Sequence** menu and click on **Stop**.
13. Close regulator and main valve and remove tubing from the Propane gas cylinder.

#### Span Gas Calibration (CH<sub>4</sub>)

1. Pull down the **Sequence** menu. Click **Settings**.
2. Click on the Calibration index-card, if it is not already at the front.
3. Click to select Gas Span Calibration radio-button.
4. Click in the Active filter field Ammonia and select the **CH<sub>4</sub> (Methane)**, and check **Perform Cross Interference Calibration** and input the concentration of methane gas.

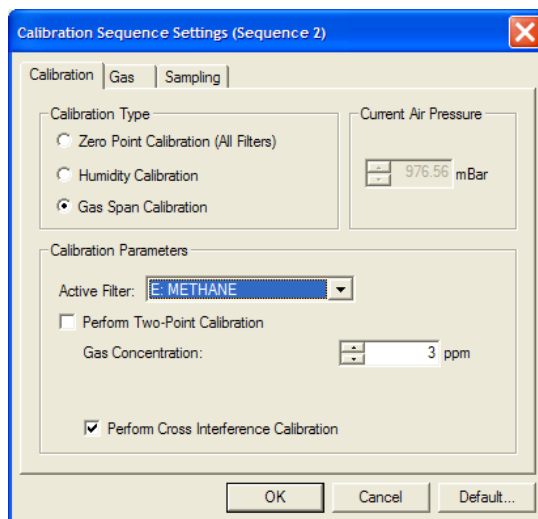

5. Click on the Gas index-card and click in the Sample Integration Time field, and select the desired time.
6. When all the settings are correct, click on **OK**.
7. Pull down the **Sequence** menu and click on **Start**.
8. Connect the 1/4" ID tubing (from the Methane gas cylinder) to the flow meter mounted on the side of the instrument rack; then open the regulator valve to allow gas flow. Methane gas is now flowing from the cylinder to the 1412.
9. Adjust regulator valve until vent airflow is about 2.5 L/min (read from bottom of ball of the flow meter mentioned above). This provides a little extra gas to the 1412 and keeps the pressure inside the manifold close to the atmospheric pressure.
10. Record time and analyzer display in lab notebook.
11. Continuously inject the gas for 5 min after display is stabilized.
12. Pull down the **Sequence** menu and click on **Stop**.
13. Close regulator and main valve and remove tubing from the Methane gas cylinder.

#### Span Gas Calibration (N<sub>2</sub>O)

1. Pull down the **Sequence** menu. Click **Settings**.
2. Click on the Calibration index-card, if it is not already at the front.
3. Click to select **Gas Span Calibration** radio-button.
4. Click in the Active filter field Ammonia and select the **Nitrous Oxide**, and check **Perform Cross Interference Calibration** and input the concentration of N<sub>2</sub>O gas.
5. Click on the Gas index-card and click in the Sample Integration Time field, and select the desired time.
6. When all the settings are correct, click on **OK**.
7. Pull down the **Sequence** menu and click on **Start**.
8. Connect the 1/4" ID tubing (from the N<sub>2</sub>O gas cylinder) with a Nafion tubing, and then connect to the manifold; then open the regulator valve to allow gas flow. N<sub>2</sub>O gas is now flowing from the cylinder to the 1412.

9. Adjust regulator valve until vent airflow is about 2.5 L/min (read from bottom of ball of the flow meter mentioned above). This provides a little extra gas to the 1412 and keeps the pressure inside the manifold close to the atmospheric pressure.
10. Record time and analyzer display in lab notebook.
11. Continuously inject the gas for 5 min after display is stabilized.
12. Pull down the **Sequence** menu and click on **Stop**.
13. Close regulator and main valve and remove tubing from the N<sub>2</sub>O gas cylinder.

### Calculating Calibration Factors

With the raw measurement data displayed on screen:

1. Open the Cursor Values dialogue.

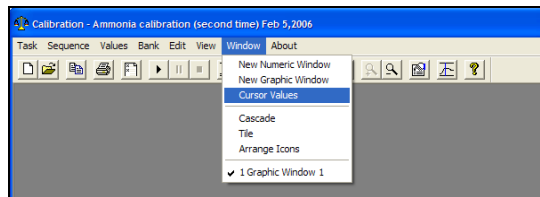

2. Use two cursors and the statistical data are displayed in the Cursor Values dialogue to locate a suitable range of data. All values in the select interval should be very stable and the temperature should be above 40°C.

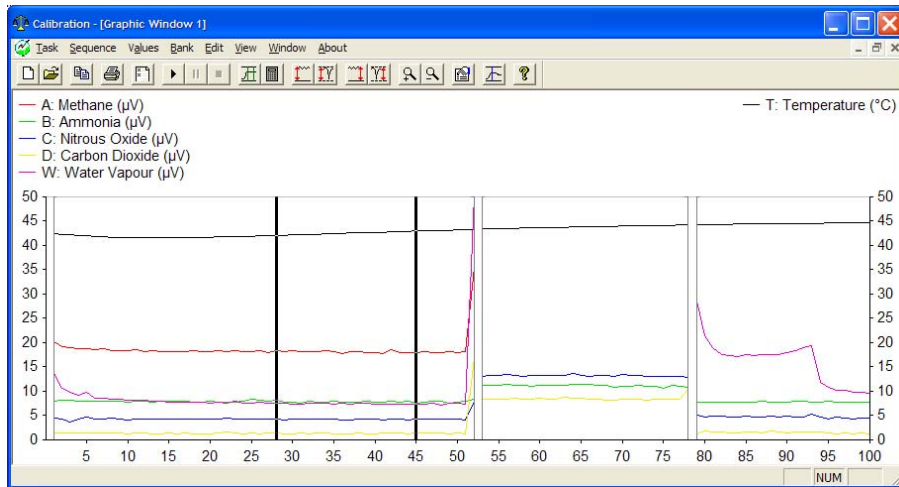
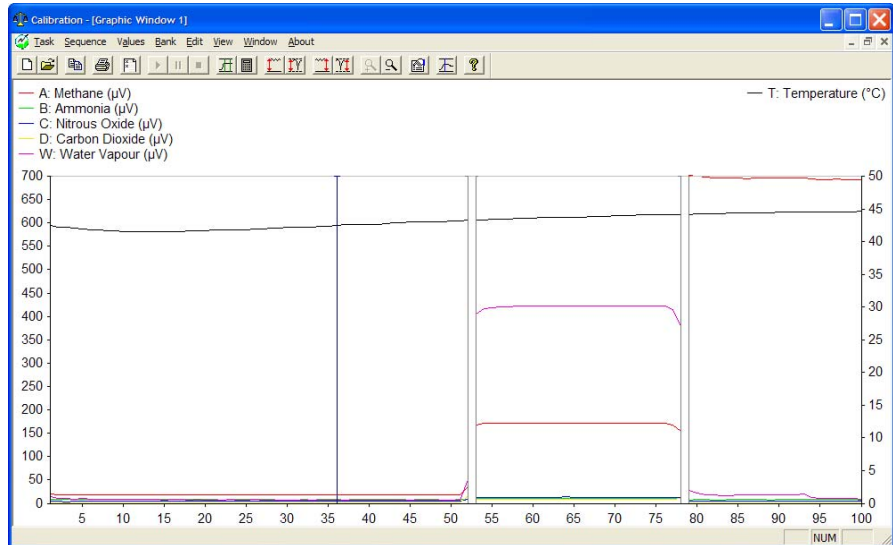

- When you have the desired region between the cursors, pull down the **Sequence** menu and click on **Mark Interval**. The two cursors are replaced by a pair of green lines. These lines have markings at the end of them, which show the type of calibration data lying between the lines. The markings are:
  - ZP: shows a zero point calibration
  - HI: shows a humidity interference calibration
  - SHA: shows a span calibration (filter A)
  - SHB: shows a span calibration (filter B)
  - SHC: shows a span calibration (filter C)
  - SHD: shows a span calibration (filter D)
  - SHE: shows a span calibration (filter E)



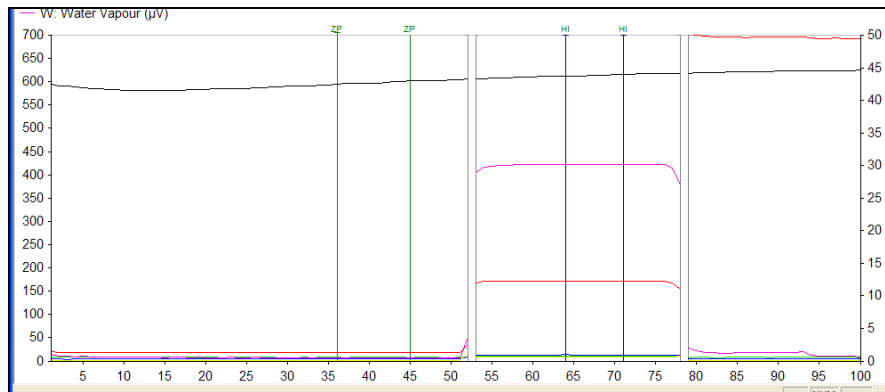
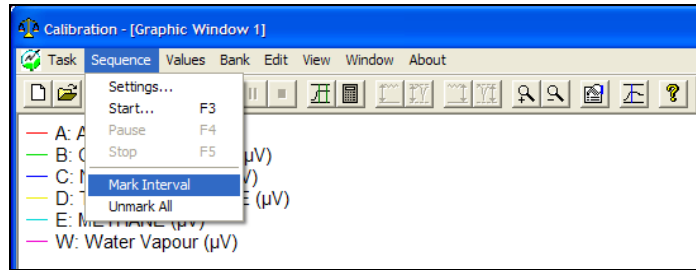

4. Select and mark all the intervals for every calibration.
5. Pull down the **values** menu and click on **calculate**.

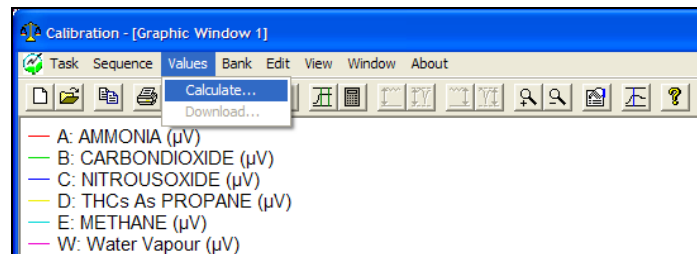

6. When the calculation(s) is complete a Calculation Finished dialogue is displayed.

To download the calculated values

1. Pull down the **Values** menu. Click on **Download** and the Download dialogue is displayed.
2. Select the **Zero Point** index card
3. Set ticks in the NH<sub>3</sub>, CO<sub>2</sub>, Propane and Methane and Water Vapor check boxes.
4. Repeat steps 2 and 3 in the **Humidity** and **Gas** index cards.
5. Click on **OK**. The calibration factors are now downloaded to the monitor.

Post Calibration

1. Check and close main valves on all cylinders
2. Calibration of the 1412 monitor is complete
3. Turn off the 1412 and disconnect 1412 with the PC.
4. Reconnect the 1412 with compact Fieldpoint and turn on the 1412.

5. Set the filter sampling integration time back to original setup: 1 s for each filter.  
**Setup→Configuration→Filters→Filter A→YES→1s S.I.T→Filter B→YES→1s S.I.T→Filter C→YES→1s S.I.T→Filter D→YES→1s S.I.T→Filter E→YES→Water Filter→ YES→1s**
6. The communication parameters necessary for the monitor to communicate with the compact Fieldpoint are shown below:

Baud rate	9600
Stop bits	2
data bits	7
Parity	Even
Hardwire mode	Leased line
Handshake type	Hard wired

Print data log and print error log must be set as shown below:

Text line Terminator	CR-LF
Print Data Log	<b>Yes</b>
Print Error Log	No

**Setup→ CONFIGURATION→System→General→Test→ Self test→Yes→Print Data Log→Yes→Print Error Log→NO**

## Routine Checking

### Zero and Span Check Procedure for Analyzer Only

- Detach the air inlet tube from the existing sampling manifold. Close the pipe adapter of the sampling manifold with a cap or plug.
- Attach the 1412 to a calibration manifold.

#### Zero Gas Check

1. Insert the 1/4" ID tubing (from the NH<sub>3</sub> gas cylinder) into the manifold connected to the valve; then open the regulator valve to allow gas flow. Zero gas is now flowing from the cylinder to the 1412.
2. Adjust regulator valve until vent airflow is about 2.5 L/min (read from bottom of ball of the monitoring flow meter). This provides a little extra zero air to the 1412 and keeps the pressure inside the manifold close to the atmospheric pressure.
3. Close regulator and remove tubing from the zero gas cylinder after display is stabilized (typically 5 to 10 minutes).

#### Span Gas Check (NH<sub>3</sub>)

1. Insert the 1/4" ID tubing (from the NH<sub>3</sub> gas cylinder) into the manifold connected to the valve; then open the regulator valve to allow gas flow. NH<sub>3</sub> gas is now flowing from the cylinder to the 1412.
2. Adjust regulator valve until vent airflow is about 2.5 L/min (read from bottom of ball of mounted on the side of the instrument rack). This provides a little extra gas to the 1412 and keeps the pressure inside the manifold close to the atmospheric pressure.

3. Close regulator and main valve and remove tubing from the  $\text{NH}_3$  gas cylinder after display is stabilized (typically 5 to 10 minutes).

#### Span Gas Check ( $\text{CO}_2$ )

1. Connect the 1/4" ID tubing (from the  $\text{CO}_2$  gas cylinder) with a Nafion tubing, and then connect to the manifold; then open the regulator valve to allow gas flow.  $\text{CO}_2$  gas is now flowing from the cylinder to the 1412.
2. Adjust regulator valve until vent airflow is about 2.5 L/min (read from bottom of ball of mounted on the side of the instrument rack). This provides a little extra gas to the 1412 and keeps the pressure inside the manifold close to the atmospheric pressure.
3. Close regulator and main valve and remove tubing from the  $\text{CO}_2$  gas cylinder after display is stabilized (typically 5 to 10 minutes).
4. Check and close main valves on all cylinders.

#### Span Gas Check ( $\text{CH}_4$ )

1. Insert the 1/4" ID tubing (from the  $\text{CH}_4$  gas cylinder) into the manifold connected to the valve; then open the regulator valve to allow gas flow.  $\text{CH}_4$  gas is now flowing from the cylinder to the 1412.
2. Adjust regulator valve until vent airflow is about 2.5 L/min (read from bottom of ball of mounted on the side of the instrument rack). This provides a little extra gas to the 1412 and keeps the pressure inside the manifold close to the atmospheric pressure.
3. Close regulator and main valve and remove tubing from the  $\text{CH}_4$  gas cylinder after display is stabilized (typically 5 to 10 minutes).
4. Check and close main valves on all cylinders.

#### Span Gas Check (Propane)

1. Insert the 1/4" ID tubing (from the Propane gas cylinder) into the manifold connected to the valve; then open the regulator valve to allow gas flow. Propane gas is now flowing from the cylinder to the 1412.
2. Adjust regulator valve until vent airflow is about 2.5 L/min (read from bottom of ball of mounted on the side of the instrument rack). This provides a little extra gas to the 1412 and keeps the pressure inside the manifold close to the atmospheric pressure.
3. Close regulator and main valve and remove tubing from the Propane gas cylinder after display is stabilized (typically 5 to 10 minutes).
4. Check and close main valves on all cylinders.

#### Span Gas Check ( $\text{N}_2\text{O}$ )

1. Connect the 1/4" ID tubing (from the  $\text{N}_2\text{O}$  gas cylinder) with a Nafion tubing, and then connect to the manifold; then open the regulator valve to allow gas flow.  $\text{N}_2\text{O}$  gas is now flowing from the cylinder to the 1412.
2. Adjust regulator valve until vent airflow is about 2.5 L/min (read from bottom of ball of mounted on the side of the instrument rack). This provides a little extra gas to the 1412 and keeps the pressure inside the manifold close to the atmospheric pressure.

3. Close regulator and main valve and remove tubing from the N<sub>2</sub>O gas cylinder after display is stabilized (typically 5 to 10 minutes).
4. Check and close main valves on all cylinders.

### **Manufacturer Contact Information**

Innova AirTech Instruments  
Energivej 30  
DK-2750 Ballerup, Denmark  
Fax: (+45) 44 20 01 01  
innova@innova.dk  
www.innova.dk

### **Reference**

1412 Photoacoustic Field Gas-Monitor Technical Document, INNOVA Air Tech Instruments.

**Maintenance/Calibration Record Sheet for INNOVA 1412 Multi-Gas Monitor**

Date of Calibration		Calibrated by:	
Time	Items	Unit =	Notes
	Ambient pressure, (mm Hg)		
: :	Sample airflow (L/min)		
: :	Zero air applied	---	Cylinder P: ___ psi
: :	NH <sub>3</sub> reading		
: :	CO <sub>2</sub> reading		
	N <sub>2</sub> O reading		
	CH <sub>4</sub> reading		
	Propane reading		
: :	CO <sub>2</sub> (_____ ppm) applied (with Nafion tubing)	---	Cylinder P: ___ psi
: :	CO <sub>2</sub> reading		
: :	NH <sub>3</sub> (_____ ppm) applied	---	Cylinder P: ___ psi
: :	NH <sub>3</sub> reading		
: :	CH <sub>4</sub> (_____ ppm) applied	---	Cylinder P: ___ psi
	CH <sub>4</sub> reading		
: :	Propane (_____ ppm) applied	---	Cylinder P: ___ psi
	Propane reading		
: :	N <sub>2</sub> O (_____ ppm) applied	---	Cylinder P: ___ psi
	N <sub>2</sub> O reading		
: :	New calibration	Yes/No	
: :	Zero air applied		
: :	Zero humidity air applied		
: :	NH <sub>3</sub> applied		
: :	CO <sub>2</sub> applied (with Nafion tubing)		
: :	Propane applied		
: :	CH <sub>4</sub> applied		
: :	N <sub>2</sub> O applied		
: :	Download to bank	Yes/No	
: :	Time switch off	---	
: :	Connect analyzer back to sampling system.		
Note:			