

2000

Establishing Criteria for Sidewall Air Inlet Performance and Evaluation of Four Commercial Inlets on This Criteria

Steven J. Hoff
Iowa State University, hoffer@iastate.edu

Cheng Gang Wu
Iowa State University

Follow this and additional works at: http://lib.dr.iastate.edu/abe_eng_pubs



Part of the [Agriculture Commons](#), and the [Bioresource and Agricultural Engineering Commons](#)

The complete bibliographic information for this item can be found at http://lib.dr.iastate.edu/abe_eng_pubs/349. For information on how to cite this item, please visit <http://lib.dr.iastate.edu/howtocite.html>.

This Article is brought to you for free and open access by the Agricultural and Biosystems Engineering at Iowa State University Digital Repository. It has been accepted for inclusion in Agricultural and Biosystems Engineering Publications by an authorized administrator of Iowa State University Digital Repository. For more information, please contact digirep@iastate.edu.

Establishing Criteria for Sidewall Air Inlet Performance and Evaluation of Four Commercial Inlets on This Criteria

Abstract

Four commercially available sidewall air inlets and one sharp-edged rectangular opening were tested in a full-scale building section under similar isothermal conditions. Large differences were found between inlets for airjet spread, axial velocity decay, airjet throw, and entrainment ratio. A criterion was derived for evaluating inlets utilizing airjet throw, airjet spread, entrainment ratio, and animal-level velocity. The criterion developed highlighted some deficiencies of the commercially available inlets at a recommended building operating pressure of 12.4 Pa.

Keywords

Inlets, Ventilation, Airjets, Efficiency, Performance criteria

Disciplines

Agriculture | Bioresource and Agricultural Engineering

Comments

This article is from *Transactions of the ASAE* 43, no. 3 (2000): 735–743.

ESTABLISHING CRITERIA FOR SIDEWALL AIR INLET PERFORMANCE AND EVALUATION OF FOUR COMMERCIAL INLETS ON THIS CRITERIA

S. J. Hoff, C. G. Wu

ABSTRACT. *Four commercially available sidewall air inlets and one sharp-edged rectangular opening were tested in a full-scale building section under similar isothermal conditions. Large differences were found between inlets for airjet spread, axial velocity decay, airjet throw, and entrainment ratio. A criterion was derived for evaluating inlets utilizing airjet throw, airjet spread, entrainment ratio, and animal-level velocity. The criterion developed highlighted some deficiencies of the commercially available inlets at a recommended building operating pressure of 12.4 Pa.*

Keywords. *Inlets, Ventilation, Airjets, Efficiency, Performance criteria.*

Thermal and indoor air quality are important environmental conditions directly affecting an animal's production efficiency, growth, and comfort. Fresh-air distribution plays a dominant role in accomplishing efficiency in these areas. A common ventilation arrangement is to allow fresh air to flow along the ceiling allowing entrainment and mixing to occur in the ventilated space. Many sidewall air inlet (SWAI) manufacturers have designed various types of inlets to meet the needs of ventilation and air distribution, however, inlet design criteria and performance are limited in enclosed spaces where they are intended. Research is needed to evaluate commercially available inlets to understand the behavior of room ventilation airflow patterns.

OBJECTIVES

The objective of this research project was to evaluate four commercial and one sharp-edged rectangular (SWAI) for airjet performance and air distribution in a building section representative of a livestock facility. The sharp-edged inlet was used as a comparison inlet where well-established performance data is available. The ultimate objective of this research project was to establish a performance criteria for evaluating air inlets in research testing.

LITERATURE REVIEW

Kacker and Whitelaw (1971) investigated the turbulence characteristics of two-dimensional walljets. They used static pressure distribution, mean velocity profiles, and

wall shear stress to describe the mean properties of airjets. They used turbulence intensity, turbulent shear stress, and a turbulent energy balance to describe airjet properties. They concluded that detailed measurements were required to demonstrate the complexity of walljet flows and confirmed that a satisfactory prediction of the mean and fluctuating properties was a formidable task.

Walker (1977) reviewed the theoretical relationships of isothermal ventilating airjets. Proper selection of inlet size and design, direction of air movement, airjet throw, entrainment, and spread of ventilation jets were required to predict system performance and to design an effective ventilation system. The review of theory included a free jet issuing from a circular hole and a free jet issuing from an infinitely long slot. He concluded that airjet theory could be used to describe velocity decay, entrainment, and airjet spread for many types of inlets and ventilation configurations.

Boon (1978) tested airflow patterns for various inlet arrangements and ventilation configurations. In most commercial livestock buildings, airspeed at animal level is greatly affected by the rate of ventilation. Temperature, relative humidity, airspeed, ventilation rate, and air movement were measured. Two stable airflow patterns were observed. Temperature variations from floor to ceiling relied on the direction of air movement. Temperature variations near the floor were found to be of at least $\pm 2^\circ\text{C}$.

Leonard and McQuitty (1987) investigated design criteria of ventilation inlets for animal housing. They concluded that a minimum Jet Momentum Number of 7.5×10^{-4} was required for developing a stable airflow pattern in isothermal situations.

Ogilvie et al. (1990) investigated the effects of air inlets and floor layout on animal-level airspeed. They studied the relationship between jet momentum and airflow pattern near the floor. They found that the location and type of air inlets and the pen layout were two important components of a space ventilation system. They found that Jet Momentum Number (J) and the airflow to floor area ratio (Q/A), both indices of energy input into a room, correlated well with floor airspeed.

Article has been reviewed and approved for publication by the Structures & Environment Division of ASAE.

Journal Paper No. J-15863 of the Iowa Agriculture and Home Economics Experiment Station, Ames, Iowa. Project No. 3140.

The authors are **Steven J. Hoff**, *ASAE Member Engineer*, Associate Professor, and **Cheng Gang Wu**, former Graduate Research Assistant, Agricultural and Biosystems Engineering Department, Iowa State University, Ames, Iowa. **Corresponding author:** Steven J. Hoff, Iowa State University, Agricultural and Biosystems Engineering Dept., 206B Davidson Hall, Ames, IA 50011-6180, phone: 515.294.6180, fax: 515.294.2255, e-mail: <hoffer@iastate.edu>.

Jin and Ogilvie (1992) investigated airflow direction and airspeed at animal level. They showed velocities in the floor region correlated well with inlet configuration, which included inlet type, dimension, location of the inlet, incoming velocity, direction, and airflow rate.

MATERIALS AND METHOD

EXPERIMENTAL APPARATUS

For this research project, a section of a livestock building was designed and built to evaluate air distribution; the building is shown in figure 1. The experimental chamber was 7.62 m (25 ft) long, 4.88 m (16 ft) wide, and 2.44 m (8 ft) high. The chamber was constructed of 38 × 89 mm wood studs spaced 61 cm on center. The inside surface was covered with 12.7-mm-thick gypsum board. The upper half of one 7.62 m sidewall consisted of 6.4 mm clear plexiglass for visualizing airflow patterns and general experiment monitoring. One end wall (fig. 1) had an inlet opening and an opening for the exhaust fan. A voltage-variance controller was used to adjust room ventilation rate. The fan was located under the wall inlet as shown in figure 1. The chamber was housed within a large building allowing the exhausted air to be recirculated, a step taken to ensure isothermal airflow.

DATA ACQUISITION, CONTROL, AND INSTRUMENTATION

A method was developed to automatically position velocity sensors in the chamber and to control the collection of data. Figure 2 outlines the positioning system developed to allow collection of airspeed data without

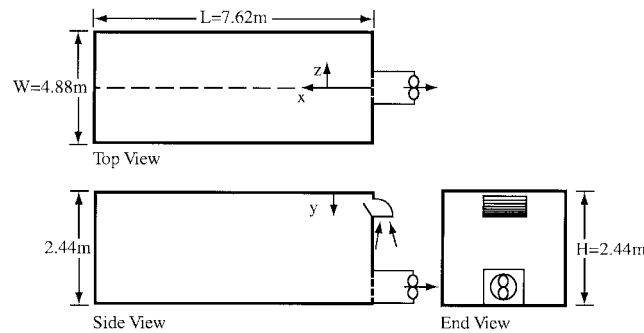

Figure 1—Test room used for study.

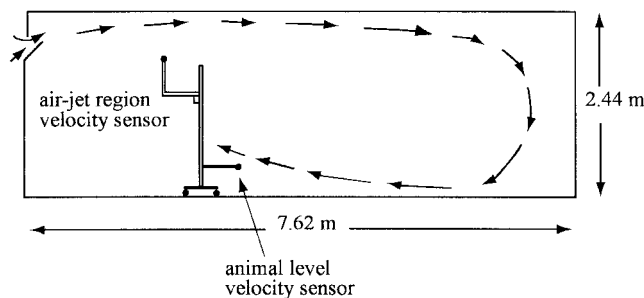

Figure 2—Automated positioning system with movable airjet anemometer and fixed animal level anemometer. Cart moves axially along the center axis of the chamber. Airjet sensor moves vertically and transverse to page. All motion handled with servomotor commands from outside the chamber (see Wu, 1994; Dhawan, 1993).

human interference. In this manner, each inlet was tested under similar conditions (Dhawan, 1993).

The positioning system uses a horizontal arm and cart that moved to commanded x, y, z locations within the chamber. Three independent servomotors separately drive sprockets for the x, y, and z directions. A computer was used to automatically control the motors and data acquisition process. The motors were digital step motors having 200 steps/rev (HY2003424-08A8, four phase, 0.8a/phase; Digital Motors, Inc.).

One velocity sensor measured airjet velocity and was located on the horizontal arm as shown in figure 2. The second velocity sensor was used to measure airjet velocity at animal level. Animal level was defined to be 25.4 cm (10 in.) above the floor (ASAE, 1998). After finishing each point in the measuring grid, the velocity sensors were automatically moved to the next measuring point. Details of the hardware and developed control scheme can be found in Dhawan (1993) and Wu (1994). The velocity sensors were omnidirectional hot-film anemometers (Model 8470; TSI, Inc.), which were able to measure very low airspeeds (0.05 m/s). The sampling rate was fixed at 8 Hz for a 180s sampling duration per measuring point.

MEASURING GRID

A total of 15 z-direction, 8 y-direction, and 6 x-direction points were sampled for each inlet tested (720 total points) (see fig. 1b for axis nomenclature). The 6 x-locations were 76, 124, 229, 305, 381, and 475 cm from the inlet sidewall. The eight y-locations were 2, 7, 13, 22, 34, 52, 84, and 122 cm from the ceiling. Fifteen z-direction samples were collected; one at z = 0 (centerline) and at ±15, ±30, ±45, ±60, ±75, ±90, and ±105 cm. Unequal x and y grids were selected to capture the rapidly changing airjet profiles in these directions. An alternative experimental grid was used to assess axial velocity decay (V_x), airjet throw (X_t), and velocity in the animal occupied zone (V_{AOZ}).

SIDEWALL INLETS TESTED

Five SWAIs were tested. Table 1 summarizes the overall features of each inlet. INLET A was constructed as a sharp-edge orifice (fig. 3a). INLET B was a spring-adjusted inlet (fig. 3b). INLET C was a counter-weighted baffle inlet as shown in figure 3c and utilized an adjustable deflecting baffle that re-directed the entering airjet. The deflecting baffle was fixed at 45° for all these experiments for test purposes only. INLET D was a self-adjusting inlet using a PVC plastic baffle as shown in figure 3d and

Table 1. Overall characteristics of each inlet investigated

| Inlet | Maximum Air Path Opening (cm × cm) | Inlet Baffle Width (cm) | Baffle Adjust Mechanism | Exterior Weather Housing | Deflecting Baffle | Baffle Hinge Location |
|-------|------------------------------------|-------------------------|-------------------------|--------------------------|-------------------|-----------------------|
| A | 10.2 × 30.5 | 30.5 | N.A.* | No | No | N.A. |
| B | 26.0 × 57.2 | 54.0 | Spring | Yes | No | Bottom |
| C | 26.8 × 53 | 53.0 | Counter-weight | Yes | Yes | Top |
| D | 13.3 × 52.7 | 51.0 | Baffle weight | No | No | Both |
| E | 35.6 × 57.2 | 55.0 | Baffle weight | Yes | Yes | Top |

* Not applicable.

INLET E was a weighted baffle inlet with a deflecting baffle as shown in figure 3e. The deflecting baffle for INLET E was fixed at 45°. The inlets were centered on one sidewall as shown in figure 1. For all SWAIs the distance from the top of the wall-inlet housing to the ceiling was fixed at 18 cm (7 in.).

Inlets B to E, representing the commercially available inlets, were not adjusted to any manufactured recommended levels. The baffle control mechanisms for Inlets B and C were fixed to a medium setting, representing the case of on-farm use with no manufacture setup procedures. The purpose of this research was not to compare performance among manufacturers, it was to evaluate a wide spectrum of inlet control methods. Inlet performance will vary as baffle control mechanisms are adjusted.

EXPERIMENTAL DESIGN

AIRJET SPREAD AND ENTRAINMENT RATIO

Airjet spread and entrainment ratio are two important parameters that describe air distribution from an inlet. The experimental grid described previously was used to determine horizontal airjet spread (θ_H) and entrainment ratio (β). Three pressure differentials, 12.4 Pa (0.05 in. H₂O), 24.8 Pa (0.10 in. H₂O), and 37.3 Pa (0.15 in. H₂O), were tested. Two replications of each treatment combination were tested with averages presented for analysis.

For each axial location in the chamber, airflow rate of the airjet was calculated by using two-dimensional numerical integration. This procedure was accomplished by

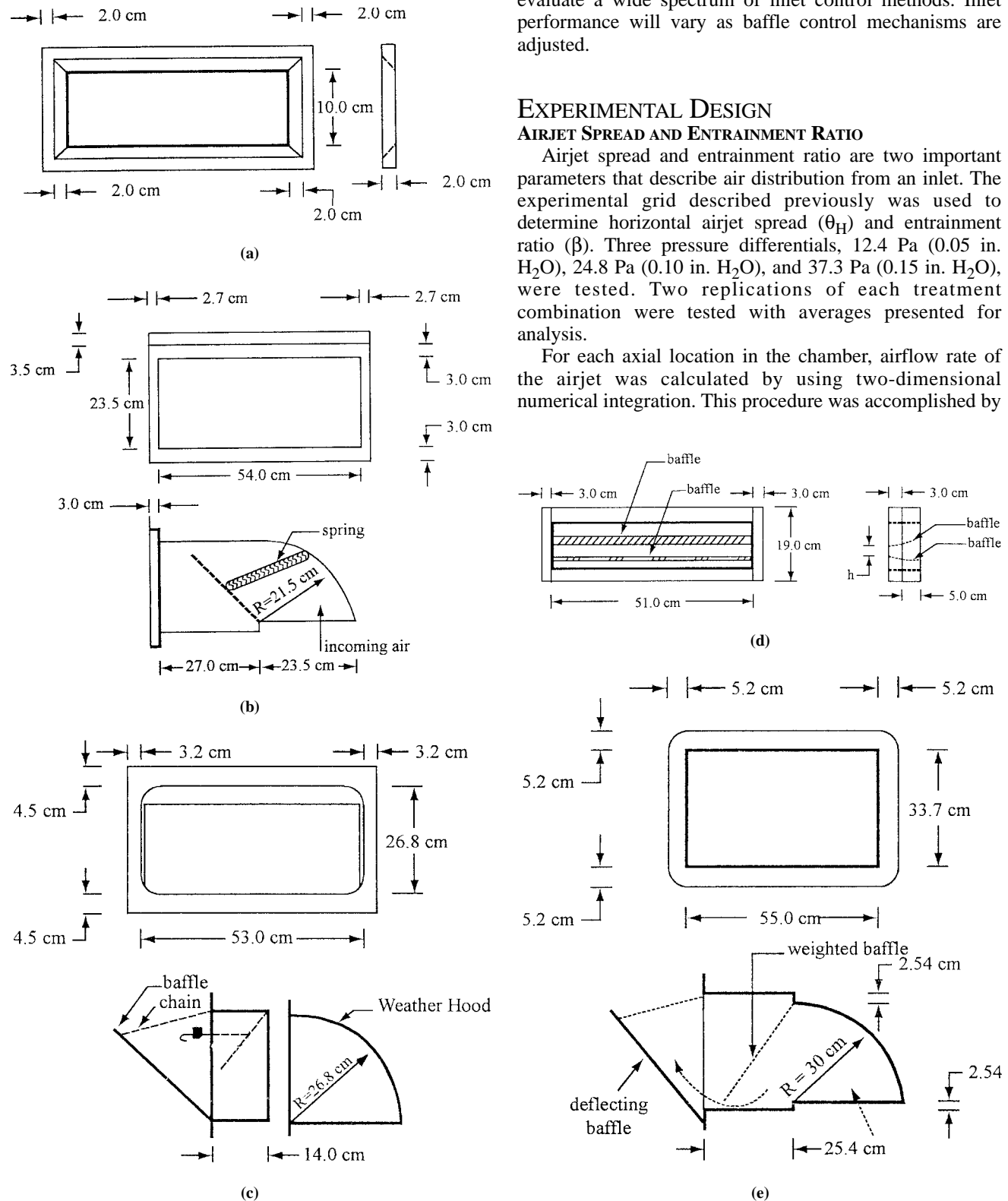

Figure 3—Wall inlets tested.

Table 2. Inlet airflow rate (m³/s) as a function of static pressure difference (Pa)

| Inlet | S.P. (Pa) | | |
|-------|-----------|-------|-------|
| | 12.4 | 24.8 | 37.3 |
| A | 0.091 | 0.125 | 0.153 |
| B | 0.057 | 0.212 | 0.313 |
| C | 0.065 | 0.176 | 0.219 |
| D | 0.049 | 0.174 | 0.256 |
| E | 0.035 | 0.115 | 0.222 |

a knowledge of the sensor location (x, y, z) and corresponding airspeed measurement. The local airflow rate at each measurement point was calculated as:

$$Q(x) = \frac{(V1 + V2 + V3 + V4)}{4} (Z_2 - Z_1) (Y_2 - Y_1) \quad (1)$$

where

- Q(x) = local volumetric airflow rate (m³/s)
- V = velocities associated with adjacent grid points (m/s)
- Z = transverse coordinates of local area (m)
- Y = vertical coordinates of local area (m)

The total airflow rate at each axial location from the inlet was determined by summing each local airflow rate determined with equation 1. Entrainment ratio (β) as a function of axial distance from the inlet was then calculated as:

$$\beta(x) = \frac{Q(x)}{Q_{inlet}} \quad (2)$$

where Q inlet is given in table 2. Inlet airflow (Q inlet) was determined from a previous research project (Oberreuter, 1995).

Horizontal airjet spread angle (θ_H) was determined to be the average transverse distance ($Z_{0.5}$) from the inlet edge ($z = W/2$) to a point at an axial location of $x = 76$ cm where airflow velocity was reduced to 0.50 m/s (see fig. 9). Equation 3 describes the relation:

$$\theta_H = 2.0 \tan \left(\frac{Z}{76} \right) \quad (3)$$

where

- θ_H = horizontal airjet spread angle
- Z = ($Z_{0.5} - 0.5 \times W$) (cm)
- W = inlet baffle width (cm) (see table 1)

AXIAL VELOCITY DECAY AND ANIMAL-LEVEL AIRSPEED

The maximum centerline velocity was defined as the maximum velocity in the airjet at selected axial locations from the inlet on the inlet center line. The maximum centerline velocity was determined by collecting velocity data at vertical locations 2 (y1), 7 (y2), 13 (y3), and 22 cm (y4) from the ceiling and 12 axial locations from the inlet. The 12 axial locations were 35, 46, 69, 115, 161, 207, 297, 365, 433, 500, 566, and 633 cm from the inlet end wall. Thus, at each axial location, the maximum velocity from y1, y2, y3, or y4 was determined and labeled as the "maximum centerline velocity" for that axial location.

Animal-level velocity (V_{AOZ}) was determined simultaneously with the axial velocity decay data described previously. Due to axial positioning differences on the automated positioning system, V_{AOZ} values were offset axially by 60 cm (see fig. 2).

TEST RESULTS AND DISCUSSION

HORIZONTAL AIRJET SPREAD ANGLE (θ_H)

Horizontal airjet spread for INLET C was the largest of all sidewall inlets tested ranging from a low of 34° at 12.4 Pa to a high of 92° at 37.3 Pa (table 3). As shown in figure 3c, air flowed through the bottom of the inlet housing, then deflected at a 45° angle to the chamber ceiling. This abrupt deflection forced air to flow out the sides of the inlet in the horizontal, or z-direction, causing a large θ_H , especially at higher static pressures. For a rectangular opening, the reported horizontal airjet spread is roughly 22° at 12.4 Pa. (Awbi, 1991). INLET A, representing the rectangular inlet, had an average measured θ_H of 20°, 25°, and 33° for 12.4, 24.8, and 37.3 Pa, respectively. INLETS B, C, and E exceeded these levels by a substantial amount, especially at 24.8 and 37.3 Pa operating pressures where θ_H levels ranged from 61 to 92°. These larger horizontal spread values were most likely the result of either the deflecting baffle or air leakage through the inlet baffle sides, as was probably the case for INLET E.

AXIAL VELOCITY DECAY (V_x)

Axial velocity decay results are shown in figures 4b to 8b for INLETS A to E, respectively. At an operating static pressure of 12.4 Pa, INLETS B and E had airjet characteristics indicating that these inlets failed to open properly at this pressure. With increasing static pressure, INLETS B and E opened, improving airjet behavior. As expected, all inlets demonstrated improved axial velocity levels with increasing static pressure. INLETS C and E demonstrated the desirable effect of deflecting baffles, where, as shown in figures 6b and 8b, the maximum airjet velocity was located some distance downstream. INLETS B to E had very low axial velocity levels at 12.4 Pa operating pressure.

Table 3. Average horizontal airjet spread (θ_H), airjet throw (X_t), maximum entrainment ratio (β_{max}), and average V_{AOZ} , maximum V_{AOZ} , and V_{AOZ} standard deviation (S.D.) for each inlet at each operating static pressure (S.P.)

| Inlet | S.P. (Pa) | θ_H (°) | X_t (cm) | β_{max} | V_{AOZ} (cm/s) | (S.D.) (cm/s) | $V_{AOZ,max}$ (cm/s) |
|-------|-----------|----------------|------------|---------------|------------------|---------------|----------------------|
| A | 12.4 | 19.9 | 700.0 | 11.0 | 7 | (2) | 11 |
| | 24.8 | 25.0 | > 762.0 | 10.8 | 12 | (2) | 16 |
| | 37.3 | 32.8 | > 762.0 | 11.2 | 13 | (3) | 18 |
| B | 12.4 | 15.2 | < 35.0 | 5.0 | < 2 | -- | < 2 |
| | 24.8 | 62.0 | 748.4 | 6.2 | 12 | (3) | 17 |
| | 37.3 | 67.4 | > 762.0 | 6.0 | 18 | (2) | 20 |
| C | 12.4 | 34.4 | 307.0 | 8.1 | 4 | (2) | 7 |
| | 24.8 | 75.1 | 325.0 | 3.8 | 4 | (2) | 7.5 |
| | 37.3 | 91.8 | 413.4 | 3.8 | 5 | (2) | 7 |
| D | 12.4 | 7.4 | 278.4 | 9.9 | 2 | (2) | 5 |
| | 24.8 | 17.0 | 611.5 | 8.5 | 15 | (2) | 18 |
| | 37.3 | 55.3 | > 762.0 | 7.5 | 17 | (2) | 20.5 |
| E | 12.4 | 2.0 | 131.7 | 9.4 | < 2 | -- | < 2 |
| | 24.8 | 61.4 | 318.4 | 7.4 | 3 | (2) | 6 |
| | 37.3 | 89.2 | 550.0 | 5.3 | 8 | (1) | 11 |

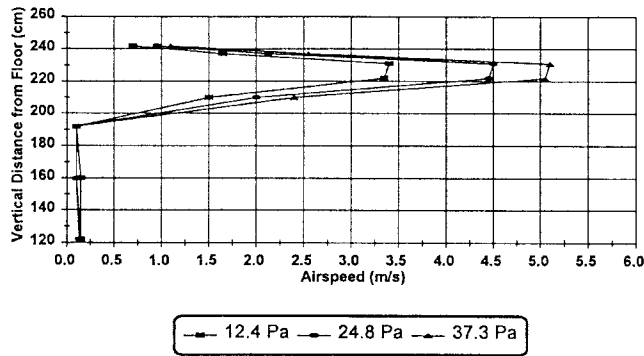

(a)

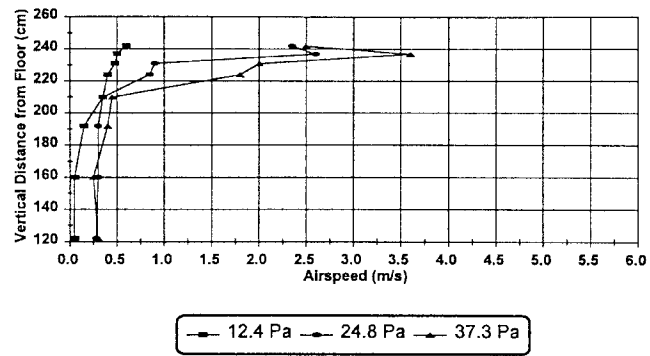

(a)

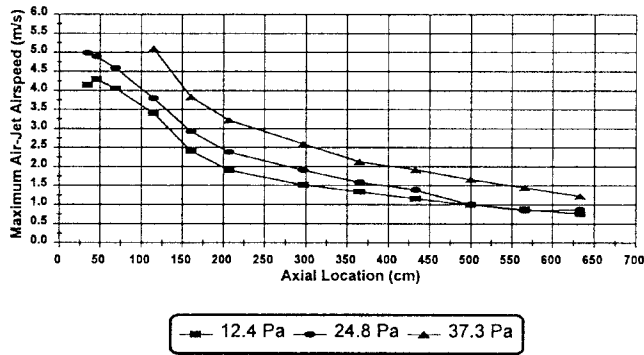

(b)

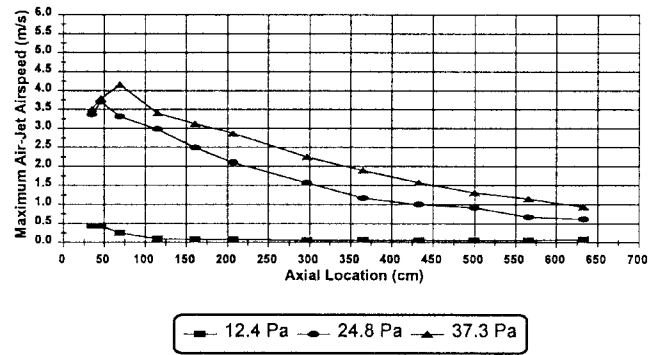

(b)

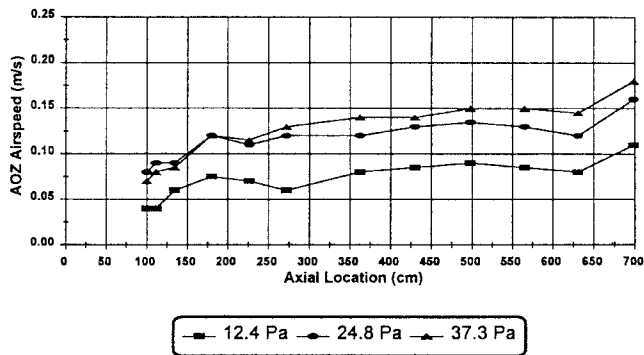

(c)

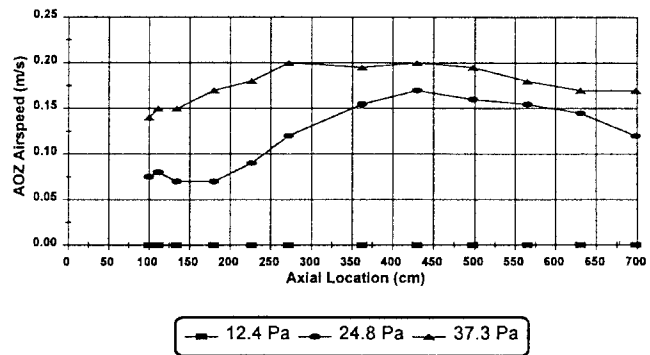

(c)

Figure 4—Inlet A airjet characteristics of (a) vertical profile at $x = 76$ cm, (b) axial velocity decay, and (c) V_{AOZ} as a function of inlet pressure difference.

Figure 5—Inlet B airjet characteristics of (a) vertical profile at $x = 76$ cm, (b) axial velocity decay, and (c) V_{AOZ} as a function of inlet pressure difference.

AIRJET THROW (X_t)

Airjet throw was defined as the axial distance from the sidewall to where the maximum center-line velocity reached 0.50 m/s (ASHRAE, 1997), and relates directly to the width of building that can be ventilated. As shown in table 3, when the static pressure was 12.4 Pa, INLET B had an immeasurable airjet throw ($X_t < 35$ cm), and INLET A had the longest airjet throw ($X_t = 700$ cm). None of the four commercial wall inlets met the Midwest Plan Service guidelines of $X_t \geq 550$ cm at 12.4 Pa (MWPS, 1990).

ENTRAINMENT RATIO (β)

Entrainment ratio (β) is the ratio of local to inlet volumetric airflow rate. The initial or entering volumetric

airflow rate for each inlet is given in table 2. Table 3 summarizes the measured peak entrainment ratios for each inlet at 12.4, 24.8, and 37.3 Pa. INLETs A, D, and E had similar β_{max} levels ranging from 11.0 to 9.4, respectively, for an operating pressure of 12.4 Pa. INLET B had a very low β_{max} level averaging about 5.7. INLETs C, D, and E demonstrated a reduced β_{max} level as operating pressure increased. This occurrence was the combined result of a large θ_H level and the inability of the measurement system to capture the entire flow net from the inlet.

ANIMAL-LEVEL VELOCITY (V_{AOZ})

Figures 4c to 8c summarize axial distribution of V_{AOZ} for each inlet at 12.4, 24.8, and 37.2 Pa. For all inlets

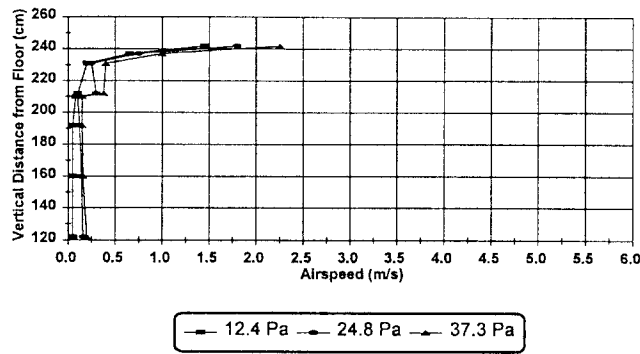

(a)

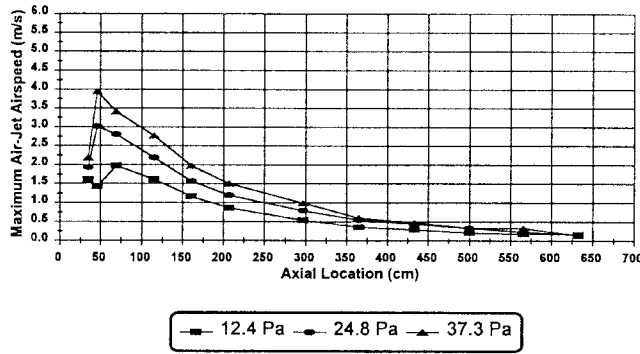

(b)

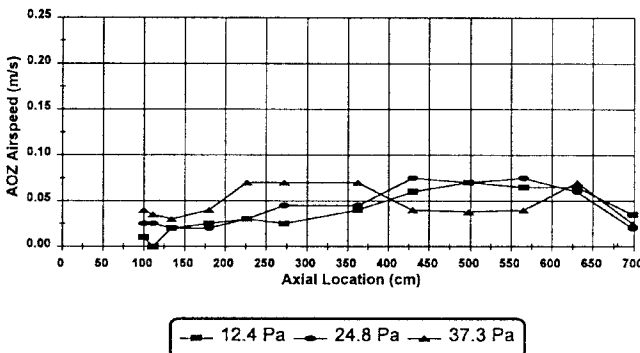

(c)

Figure 6—Inlet C airjet characteristics of (a) vertical profile at $x = 76$ cm, (b) axial velocity decay, and (c) V_{AOZ} as a function of inlet pressure difference.

tested, the maximum centerline velocity in the animal occupied zone never exceeded 0.25 m/s and was fairly constant across axial location. The average, standard deviation, and maximum V_{AOZ} are summarized in table 3.

PERFORMANCE CRITERIA

Evaluating the overall performance of each SWAI tested was a difficult task. Each inlet had at least one area in which it performed well. A standardized procedure is proposed to quantify overall performance. Of the variables investigated for this research project, airjet throw (X_t), transverse airjet spread angle (θ_H), entrainment ratio (β), and animal-level velocity (V_{AOZ}) were used to assess

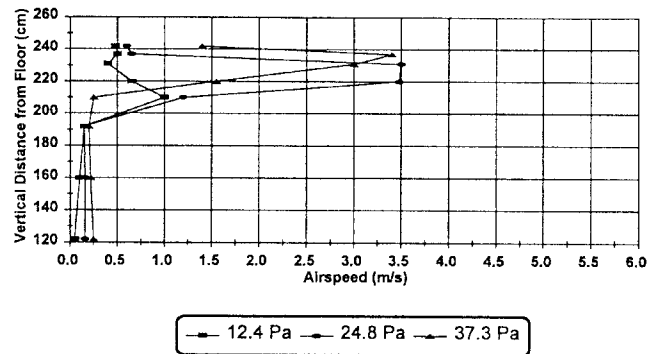

(a)

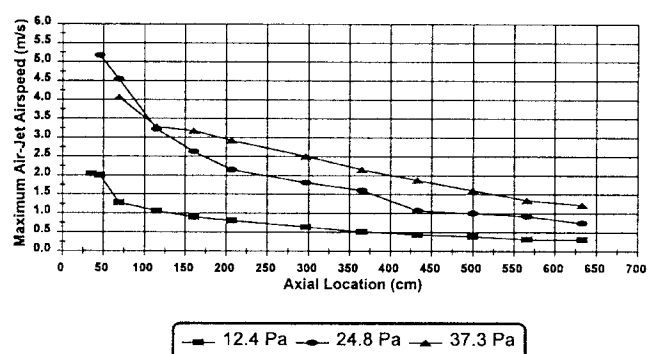

(b)

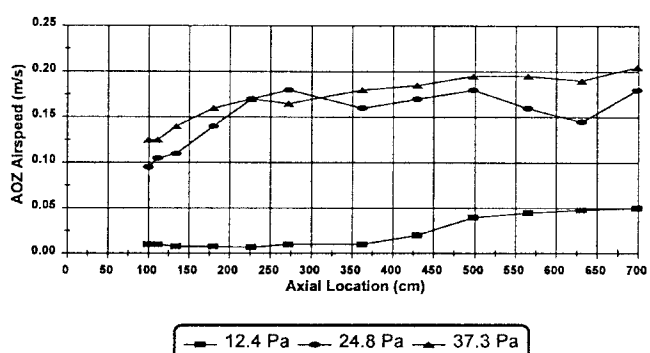

(c)

Figure 7—Inlet D air-jet characteristics of (a) vertical profile at $x = 76$ cm, (b) axial velocity decay, and (c) V_{AOZ} as a function of inlet pressure difference.

overall SWAI performance. X_t and θ_H relate directly to axial and transverse spacing of inlets; β gives a good indication of recirculation established by the inlet and therefore the dilution potential; and V_{AOZ} defines, to some degree, comfort conditions at animal level. All four variables were decided as important indicators. Future work may show that other variables are more descriptive. The overall objective was to establish a criteria which simultaneously incorporated these four variables.

AIRJET-AFFECTED HORIZONTAL AREA (A_H)

The airjet, as it penetrates the building, will directly affect an area determined by the airjet throw (X_T) and horizontal airjet spread (θ_H). The airjet-affected horizontal

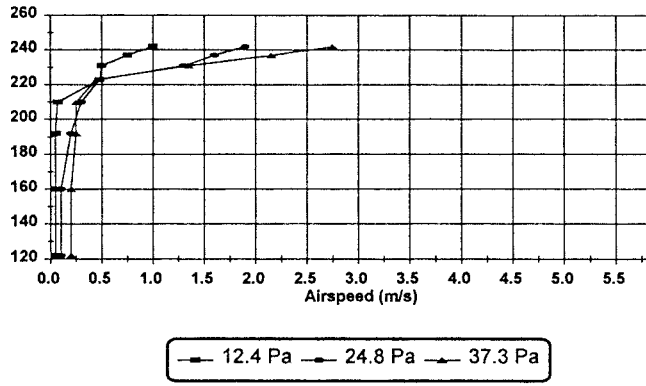

(a)

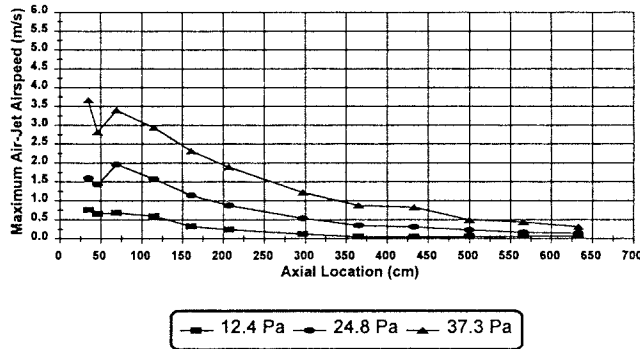

(b)

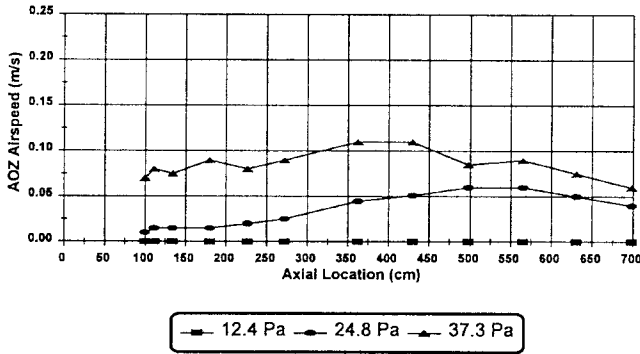

(c)

Figure 8—Inlet E airjet characteristics of (a) vertical profile at $x = 76$ cm, (b) axial velocity decay, and (c) V_{AOZ} as a function of inlet pressure difference.

area (A_H) was defined as shown in figure 9 and estimated geometrically by using:

$$A_H = X_T^2 \tan\left(\frac{\theta_H}{2}\right) + W X_T \quad (4)$$

where

- A_H = airjet-affected horizontal area (cm^2)
- X_T = airjet throw (cm)
- θ_H = horizontal airjet spread ($^\circ$)
- W = SWAI width (cm) (see table 1)

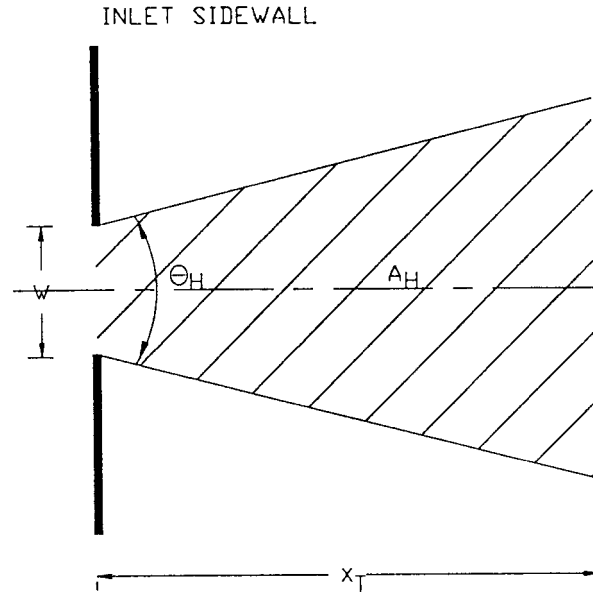

Figure 9—Top view of airjet-affected horizontal area, A_H .

An acceptable wall inlet in terms of X_T and θ_H was assumed as one which resulted in $X_T = 550$ cm and $\theta_H = 25^\circ$. An inlet's actual A_H was normalized to an "acceptable" inlet A_H rating as:

$$A'_H = \frac{A_H}{(550^2) \tan(12.5) + W(550)} \quad (5)$$

AIRJET THROW (X_T)

An acceptable inlet airjet throw was assumed to be a minimum of 550 cm. The inlet X_T was normalized as:

$$X'_t = \frac{X_t}{550} \quad (6)$$

ENTRAINMENT RATIO (β)

For airjet and room air mixing, a large entrainment ratio is desired. It was assumed that a good goal to achieve would be a minimum entrained flow of 10 times the initial volumetric flow rate. The inlet entrainment ratio was normalized as:

$$\beta' = \frac{\beta}{10.0} \quad (7)$$

ANIMAL-LEVEL VELOCITY (V_{AOZ})

The resulting maximum animal-occupied zone velocity ($V_{AOZ,max}$) was evaluated as well as the three previous airjet properties. It has been suggested (Ogilvie et al., 1996) that V_{AOZ} levels should be maintained between 0.10 and 0.40 m/s for winter ventilation rates. This suggestion was incorporated into the proposed criteria as follows:

If $0.10 \leq V_{AOZ,max} \leq 0.40$ m/s Then $V'_{AOZ,max} = 1.0$

If $V_{AOZ,max} < 0.10$ m/s Then $V'_{AOZ,max} = 0.0$

If $V_{AOZ,max} > 0.40$ m/s Then $V'_{AOZ,max} = 0.0$ (8)

However, this criteria is especially dependent upon animal species, maturity, and season. For example, mature pigs in the heat of summer would benefit from air speeds higher than 0.40 m/s. Likewise, small pigs in a wean-to-finish facility would be chilled at 0.40 m/s air speeds. More work is needed to better quantify this particular criteria; one that incorporates a weighting factor for pig age.

THE CRITERIA

Relations (4) to (8) represent normalized relations relative to the assumed desired SWAI properties. Each of the four relations were designed to be a value of 1.0 when yielding acceptable performance. Values less than 1.0 imply performance below desired levels. A summation of indicators yields:

$$\Sigma = r_1A'_H + r_2X'_t + r_3\beta' + r_4V'_{AOZ,max} \quad (9)$$

The weighting factors (r_i) represent potential weights applied to each performance criteria. For this evaluation, it was assumed that $r_i = 1.0$ (equal importance); thus an acceptable SWAI will have a $\Sigma \geq 4.0$.

Table 4 summarizes the criteria for each wall inlet studied at 12.4, 24.8, and 37.3 Pa, respectively. At 12.4 Pa, only INLET A exceeded the criteria level defined previously with a rating of 4.65. INLET B performed the poorest overall with a rating of 0.50; the result of an immeasurable airjet throw that caused a zero rating for A_H . INLETS C, D, and E performed below desired levels with ratings between 1.26 and 1.85.

Increasing the static pressure to 24.8 or 37.3 Pa greatly improved the overall performance, and hence rating, of each SWAI inlet. At 24.8 Pa, INLET B exceeded all inlets tested based on the criteria established. This is a complete reversal of the rating received at 12.4 Pa. The major contributor to this result was the exceptionally large A_H as shown in table 4. When the operating pressure was increased to 37.3 Pa, all inlets, with the exception of

Table 4. Summary performance criteria for each inlet

| Inlet | S.P. (Pa) | A_H (cm ²) | A'_H | X'_t | β' | V'_{AOZ} | Σ |
|-------|-----------|--------------------------|--------|--------|----------|------------|----------|
| A | 12.4 | 107,309. | 1.28 | 1.27 | 1.10 | 1.00 | 4.65 |
| | 24.8 | 152,040. | 1.81 | 1.39 | 1.09 | 1.00 | 5.29 |
| | 37.3 | 194,230. | 2.32 | 1.39 | 1.12 | 1.00 | 5.78 |
| B | 12.4 | 0. | 0. | 0. | 0.50 | 0. | 0.50 |
| | 24.8 | 376,957. | 3.90 | 1.36 | 0.63 | 1.00 | 6.89 |
| | 37.3 | 428,604. | 4.43 | 1.39 | 0.60 | 1.00 | 7.43 |
| C | 12.4 | 45,446. | 0.47 | 0.56 | 0.82 | 0. | 1.85 |
| | 24.8 | 98,421. | 1.02 | 0.59 | 0.36 | 0. | 1.97 |
| | 37.3 | 198,265. | 2.06 | 0.75 | 0.38 | 0. | 3.19 |
| D | 12.4 | 19,210. | 0.20 | 0.51 | 1.00 | 0. | 1.71 |
| | 24.8 | 87,071. | 0.92 | 1.11 | 0.84 | 1.00 | 3.87 |
| | 37.3 | 343,061. | 3.61 | 1.39 | 0.75 | 1.00 | 6.76 |
| E | 12.4 | 7,546. | 0.08 | 0.24 | 0.94 | 0. | 1.26 |
| | 24.8 | 77,706. | 0.80 | 0.58 | 0.74 | 0. | 2.12 |
| | 37.3 | 328,556. | 3.38 | 1.00 | 0.67 | 1.00 | 5.46 |

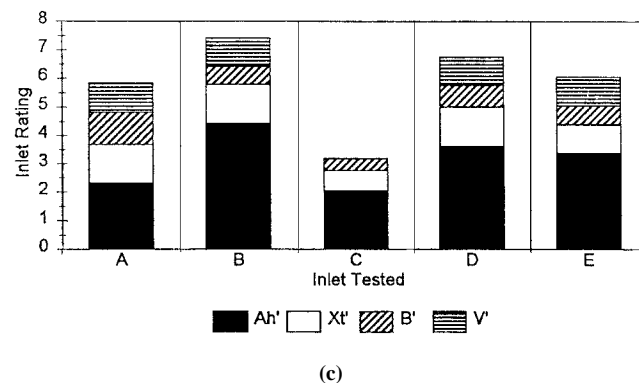
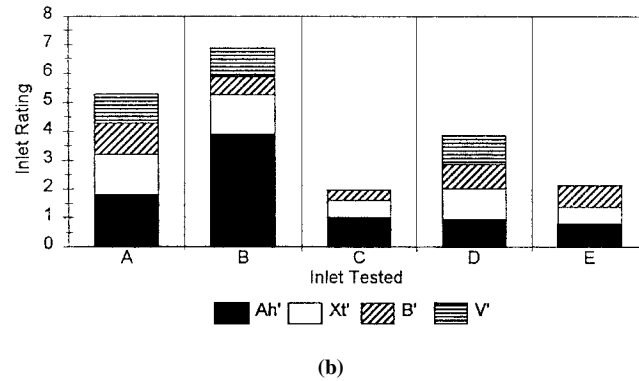
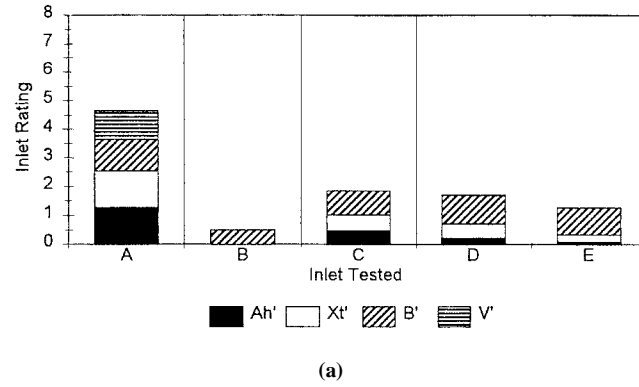

Figure 10—Inlet rating at SP levels of (a) 12.4, (b) 24.8, and (c) 37.3 Pascals (Pa).

INLET C, exceeded the proposed criteria rating of 4 (table 4) as summarized in figure 10.

SUMMARY AND CONCLUSIONS

Four commercial and one sharp-edged SWAI were tested for axial velocity decay, airjet throw, entrainment ratio, transverse airjet spread, and animal level velocity. Each SWAI was tested at three static pressure levels and two replications. All tests were conducted under similar isothermal conditions.

At current recommended building operating static pressures ($\Delta P = 12.4$ Pa), most of the four commercial SWAIs did not produce acceptable air distribution in the chamber. In general, a static pressure differential of 12.4 Pa was too small for most SWAIs to generate enough momentum energy to develop an effective inlet airjet.

Deflecting baffles, commonly attached to SWAIs, affected inlet performance in two main areas. The deflecting baffle forced fluid to disperse horizontally and along the ceiling as the airjet entered the building. This deflection decreased airjet throw in the building. Thus, a trade-off existed between horizontal and downstream areas serviced by an inlet.

A criteria was proposed to assess overall SWAI performance by using airjet throw, horizontal airjet spread, entrainment ratio, and velocity in the animal occupied zone. A parameter defined as the "airjet-affected horizontal area" was used to assess the combined influences of horizontal airjet spread and airjet throw; both are important parameters for SWAIs. The criteria linked inlet parameters to assess overall performance.

The results highlight the need for inlets that are self-adjusting and guaranteed to function properly at recommended operating pressures for the range of ventilation rates for which they are designed. Inlets that require manual adjustment often times are overlooked resulting in improper performance for a vast majority of the ventilation rates required. Inlets that require higher operating pressures for acceptable performance will overburden the fan system resulting in inefficient performance. Industries outside of agriculture provide fresh-air intakes that require little or no adjustments beyond the initial start-up procedures provided by the manufacturer. The agriculture industry should be moving as well to this policy. Producers should have available to them the predicted inlet performance during seasonal changes in ventilation rates. Inlet systems, much like fan systems of today, should be clearly identified for performance capabilities since this is the key item in the ventilation system defining proper air distribution and indoor air quality control.

REFERENCES

- ASAE Standards, 45th Ed. 1998. Proposed Standard X567. A standard for design and performance of mechanical livestock ventilation systems. In Standards Committee Review.
- ASHRAE. 1997. *Handbook of Fundamentals*. Atlanta, Ga.: American Society of Heating, Refrigerating and Air Conditioning Engineers, Inc.
- Awbi, H. B. 1991. *Ventilation of Buildings*. Book E & FN SPON. London, England: Chapman & Hall.
- Boon, C. R. 1978. Airflow patterns and temperature distribution in an experimental piggery. *J. Agric. Eng. Res.* 23: 129-139.
- Dhawan, R. 1993. Remote control of a data acquisition process. Unpub. M.S. thesis. Ames, Iowa: Iowa State University.
- Jin, Y., and J. R. Ogilvie. 1992. Airflow characteristics in the floor region of a slot ventilated room (isothermal). *Transactions of the ASAE* 3(2): 695-702.
- Kacker, S. C., and J. H. Whitelaw. 1971. The turbulence characteristics of two-dimensional wall jet and wall wake flows. *J. Applied Mechanics* 22: 239-255.
- Leonard, J. J., and J. B. McQuitty. 1987. Air mixing in a mechanically ventilated room. *Canadian Soc. Agric. Eng.* 30(1): 185-189.
- MWPS. 1990. Mechanical ventilating systems for livestock housing. MWPS-32. Ames, Iowa: MidWest Plan Service, Iowa State University.
- Oberreuter, M. E. 1995. Design and performance of automatic sidewall air inlets for livestock housing. Unpub. M.S. thesis. Ames, Iowa: Agricultural and Biosystems Engineering Dept., Iowa State University.
- Ogilvie, J. R., E. M. Barber, and J. M. Randall. 1990. Floor air speeds and inlet design in swine ventilation systems. *Transactions of the ASAE* 33(1): 255-259.
- Walker, J. N. 1977. Review of the theoretical relationships of isothermal ventilating airjets. *Transactions of the ASAE* 20(3): 517-522.
- Wu, C. G. 1994. Jet entrainment, jet spread, and jet decay from commercially available sidewall air inlets. Unpub. M.S. thesis. Ames, Iowa: Agriculture and Biosystems Engineering Dept., Iowa State University.

