

MEASUREMENT OF PARTICLE PARAMETERS IN THERMAL SPRAY SYSTEMS

J. R. Fincke, C. L. Jeffery, S. B. Englert

Idaho National Engineering Laboratory
EG&G Idaho, Inc.
Idaho Falls, ID 83415-2208

INTRODUCTION

Particle parameters are important in the optimization of plasma and flame spray processes that involve fine powders. Such processes include plasma and flame spraying, spheroidizing, and chemical processes in which the material is introduced in the form of fine powders or the final product is in the form of a fine powder, e.g. plasma synthesis of ceramics. To fully characterize the particle flow field, it is necessary to measure the particle size, velocity, and number density. In many cases, it is necessary to measure simultaneously several parameters that are strongly coupled such as particle size and temperature, or size and velocity. In this paper we will describe a laser based measurement technique for simultaneously obtaining the in-flight size, velocity, and temperature of small particles entrained in a flow field.

Particle size is determined from the absolute magnitude of scattered laser light, particle temperature is determined from a two-color pyrometer technique, and a dual crossed-beam laser Doppler velocimeter (LDV) technique is used to measure velocity. A multi-line Ar ion laser is used as the light source for velocity and sizing. The LDV measurement volume, consisting of the intersection of two 514 nm beams, is situated in the center of the larger diameter 488 nm laser beam. The intersection of the LDV measurement volume and the second beam comprises the particle size measurement volume. Simultaneously the light emitted by the hot, incandescent particle in two wavelength bands is observed; the particle temperature is derived from these two signals. The spatial resolution of $<1 \text{ mm}^3$ is such that distribution of particle size, velocity, and temperature can be mapped over an entire flow field. Typical data on a plasma spray system are presented.

PREVIOUS WORK

Particle size measurement techniques have been developed by many researchers. A variety of reviews have been published in the literature, for example, Hirleman [1] on laser-based single-particle counters and Durst [2] on combined measurement of particle size and velocity by a laser Doppler technique. The most popular technique, and one which avoids the ambiguities of the Doppler technique for widely varying particle sizes, is the measurement of the absolute magnitude of light

scattered by a particle [3-5]. If the light collection geometry is correctly chosen, then a monotonic relationship between scattered intensity and particle diameter exists. Two common geometries are near forward scattering [3] and 90° scattering [5].

The difficulty in applying the technique on a particle by particle basis lies in the so-called trajectory ambiguity. That is, a large particle crossing the edge of the control volume is confused with a smaller particle having a more median trajectory. Because of this ambiguity it is impossible to assign each signal a corresponding size, only the particle scattering probability density function may be obtained. If the assumption of trajectory equi-probability is made, then the particle size distribution may be obtained by a mathematical inversion scheme [3]. The necessity for inversion can be avoided by only recording signals from particles localized near the center of a gaussian laser beam [4] of a top-hat beam [6]. A typical technique is to locate a laser Doppler velocimeter measurement volume in the center of the sizing beam and to record size data upon observance of a valid Doppler burst.

A number of researchers have investigated techniques of obtaining in-flight temperature information on small particles. Gurevich and Shteinberg [7] described a two-color technique for measuring the temperature of burning droplets of liquid fuel. Later Kruszewska and Lesinski [8] reported the first application of an absolute radiance technique to the measurement of single-particle temperature in a plasma torch. The sample volume consisted of a chord through plasma. The technique was further developed by Vardelle et al. [9] and extended to a two-color technique by Mihsin et al. [10]. In related work, Jorgensen and Zuiderwyk [11] investigated a similar technique applied to individual combusting particles. Vardelle et al. [12] overcame the limitations of the chordal measurement by developing a coincidence technique. In this technique the plasma is viewed by two optical systems located at 90° to each other. Each system with its aperture forms a region in space where a particle, when present, will produce a signal in a detector. This intersection of these two regions forms a localized measurement volume. Recently an in-flight coincidence technique which integrates a particle temperature measure with the measurement of particle size has been demonstrated [13]. This technique uses a two-color pyrometric technique to determine temperature and the absolute magnitude of forward scattered laser light to determine particle size.

DESCRIPTION OF HARDWARE

Schematics of the optics appear in Figs. 1 and 2. The beam launching optics, Fig. 1, consist of two Brewster angle dispersing prisms which separate the individual colors in a multi-line 6 W argon ion laser beam. The blue 4880 Å beam is routed, via a 1500 mm focal length lens, and aperture/beam stop, to the measurement volume by a series of mirrors. The green 5145 Å beam is routed to the laser Doppler velocimeter optics. These optics consist of a polarization rotator, a beam splitter, a beam displacer to give the proper spacing for entry into a beam expanding telescope, and a 600 mm focal length focusing lens. The system is aligned in such a way that the LDV measurement volume (0.39 x 22 mm) is located in the center of the large (2 mm) blue sizing beam, Fig. 1. The effective length of the LDV measurement volume is further shortened to ~1 mm by the aperture P1 in the receiving optics. The localization of the LDV measurement volume in the center of the sizing beam and the requirement of coincidence between a particle size signal and Doppler burst avoids trajectory ambiguity problems.

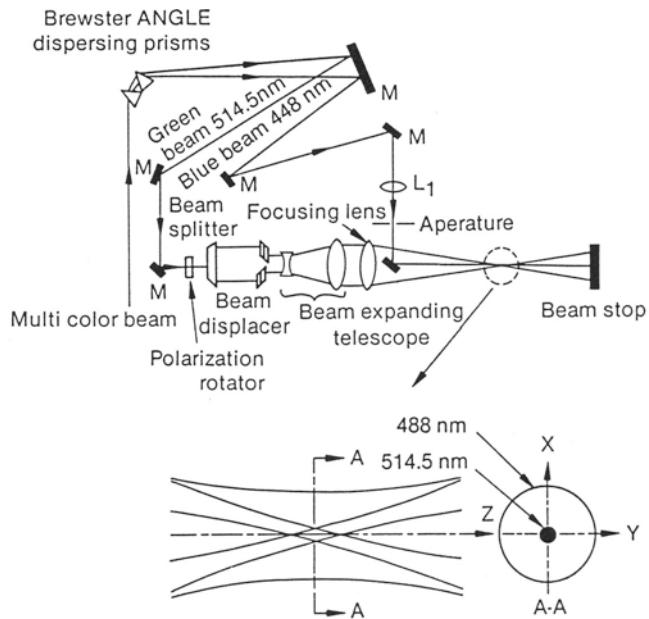

Fig. 1. Schematic of beam launching optics and measurement volume geometry.

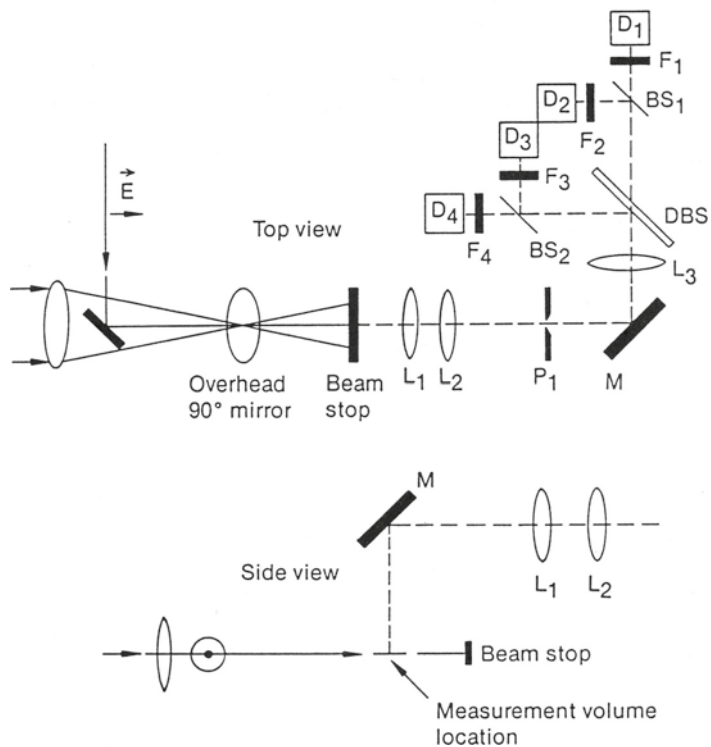

Fig. 2. Schematic of receiving optics.

The receiving optics are shown schematically in Fig. 2. Lens L_1 ($f = 350$ mm) is placed one focal length away from the measurement volume. Lens L_2 ($f = 250$ mm) forms the demagnified (1:0.71) image of the measurement volume on a 0.75 mm aperture, P_1 . The image of P_1 is transferred to the faces of detectors 1 through 4 by lens L_3 . A dichroic beam splitter (DBS) passes the light from the green and blue velocimetry and sizing beams and reflects the longer wavelength portion of the spectrum into the particle temperature detectors D_3 and D_4 through band pass filters. The filters used for pyrometry are 400 Å FWHM centered at 5500 Å and 8000 Å, respectively. The detectors used are RCA C31034 with GaAs photocathodes. The light passed by the dichroic enters the particle sizing and velocimetry detectors through laser line filters, 10 Å FWHM centered, at 4880 Å and 5145 Å, respectively.

While absolute radiance techniques have inherently smaller measurement uncertainties than two-color techniques, knowledge of the particle size and emissivity is required. The absolute radiance techniques also suffer from a trajectory ambiguity problem. That is, a small particle centered on the measurement volume may give the same signal as a large particle on the edge of the measurement volume. Additionally, in a system in which vaporization is taking place the particle size is continually changing. The two-color technique avoids this ambiguity by using a common aperture and taking the ratio of signals in each of two wavelength ranges. This ratio is a function of the relative sensitivities of the two detector systems, the ratio of surface emissivities, and the particle temperature.

The current pulse emitted by the photomultipliers upon observation of a particle is converted to a voltage pulse by 50 Ω input, DC, 150 MHz response, pulse amplifiers. Additional electronics are shown in Fig. 3. A TSI Model 1980 counter type signal processor is used to derive velocity data from individual Doppler bursts. The data-ready pulse gates a programmable clock (LeCroy 8501) which then controls four DSP Model 2824 digitizers. A DSP TRAQI Model 4012A system controller and 128K Model 5200 memodule complete the data recording system. Once the programmable clock is triggered a predetermined number of samples (generally twenty) are recorded by the individual digitizers. The sample rate is set according to the general characteristics of the wave forms generated by the passage of each individual particle. After acquisition of a predetermined number of particle waveforms, the data are transferred to a microcomputer for subsequent processing. The dynamic range of the particle size measurement is extended by the use of a home-built log amplifier circuit. This circuit provides approximately three decades of usable range.

CALIBRATION AND MEASUREMENT UNCERTAINTY

Calibration of the pyrometer system was performed using a tungsten ribbon lamp placed behind a chopper rotating at constant speed. The temperature of the tungsten ribbon was determined by a disappearing wire pyrometer. Using the calibration data, the constants A and B in Equation (1) were determined by a nonlinear curve fitting procedure, where R is the ratio of voltages from the two pyrometer channels, and ϵ_2/ϵ_1 is the ratio of emissivities:

$$T = \frac{A}{\ln(B(\epsilon_2/\epsilon_1)R)}$$

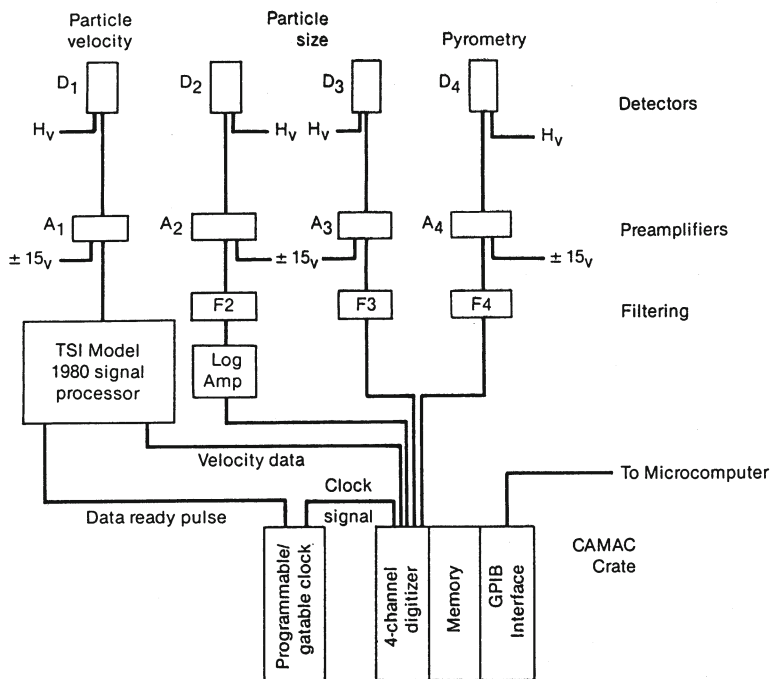

Fig. 3. Schematic of analog electronics and digital data acquisition.

The uncertainties in the determination of temperature arise from uncertainties in the coefficients A and B, the ratio of emissivities, and random fluctuations in the ratio of voltages, R. The propagation of these uncertainties into the determination of temperature may be estimated in the usual manner [14]. The resulting expression is:

$$\frac{\Delta T}{T} = \left(\left(\frac{T}{A} \right)^2 \left[\left(\frac{\Delta B}{B} \right)^2 + \left(\frac{\Delta R}{R} \right)^2 + \left(\frac{\Delta \epsilon_2 / \epsilon_1}{\epsilon_2 / \epsilon_1} \right)^2 \right] + \left(\frac{\Delta A}{A} \right)^2 \right)^{1/2} \quad (2)$$

The random error in R is evaluated from the calibration data and results in an uncertainty of 42 K. The uncertainties in the coefficients A and B are estimated from the statistics of the curve fit and are 3% and 8.1% respectively. The error due to the assumption of a gray body is 2% or less. This leads to an estimated one standard deviation uncertainty in temperature of 125 K at 2500 K. The major source of this uncertainty is random fluctuations and long-term drift in the photomultipliers.

Calibration of the particle size measurement system is performed against a Berglund-Liu vibrating orifice aerosol generator and against particles which have been sieved into narrow size cuts. A typical calibration curve appears in Fig. 4 and a typical particle size histogram appears in Fig. 5 for 66 μm particles. Also shown in Fig. 5 are 83.2 and 95 μm particles formed by agglomeration of two and three particles.

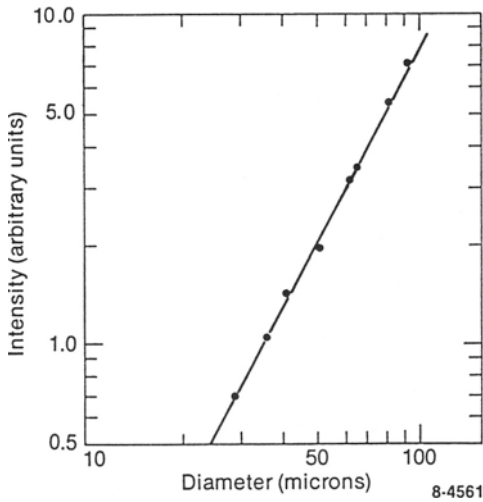

Fig. 4. Typical particle size calibration curve.

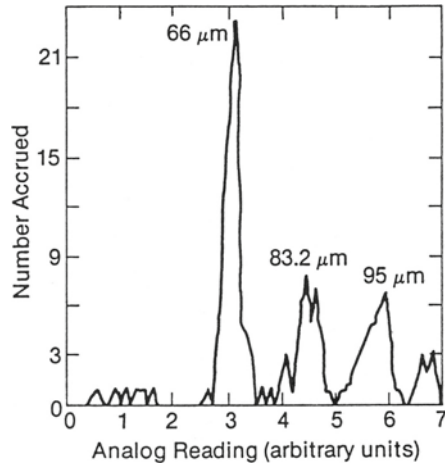

Fig. 5. Typical particle size calibration data using Berglund Liu vibrating orifice, principal particle size is 66 μm .

TYPICAL RESULTS

A representative sample of typical results will be presented. Fig. 6 is a comparison of centerline particle temperatures for 40 and 70 μm particles in a plasma spray torch. As expected, the smaller mean diameter particles are slightly hotter upon exiting the torch and cool more rapidly. A three-dimensional distribution of particle size and temperature appears in Fig. 7, illustrating the ability to cross-correlate size and temperature data. For the conditions tested, it is apparent that no simple functional relationship exists between particle size and temperature. It does, however, appear that the larger particles have a narrower temperature distribution than the smaller particles and a slightly lower mean temperature.

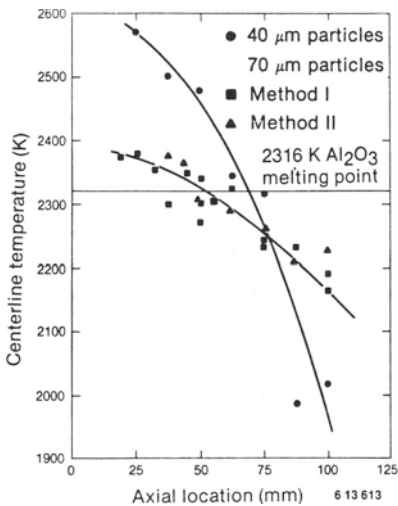

Fig. 6. Comparison of Centerline particle temperatures.

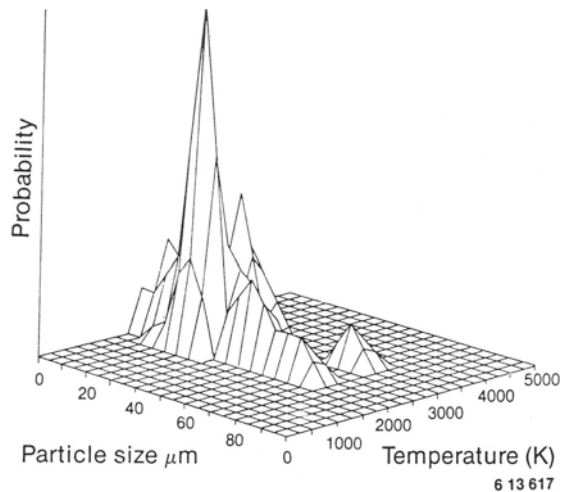

Fig. 7. Distribution of particle size and temperature.

ACKNOWLEDGMENT

This work was supported by the Division of Engineering, Mathematical and Geosciences, Office of Basic Energy Sciences, U.S. Department of Energy under Contract No. DE-AC07-76ID01570.

REFERENCES

1. Hirleman, E. E., *Optical Engineering* 19:854-860 (1980).
2. Durst, F., *Transactions of the ASME, Journal of Fluids Engineering* 104:284-296 (1982).
3. Holve, D. J., *Journal of Energy* 4:176-183 (1980).
4. Hess, C. F., *Applied Optics* 23:4375-4382 (1984).
5. Grehan, G., Govesbet, G. and Rabasse, C., *Applied Optics* 20:796-799 (1981).
6. Grehan, G. and Grovesbet, G., *Applied Optics* 25:3527-3538 (1986).
7. Gurevich, M. A. and Shteinberg, V. B., *Soviet Physics--Technical Physics* 3:368-375 (1958).
8. Kruszewska, B. and Lesinski, J., *Revue De Physique Appliquee* 12:1209-1211 (1977).
9. Vardelle, A., Baronnet, J. M., Vardelle, M., and Fauchais, P., *IEEE Transactions on Plasma Science*, PS-8:417-424 (1980).
10. Mihsin, J., Vardelle, M., Lesinski, J. and Fauchais, P., 7th International Symposium on Plasma Chemistry, Eindhoven, 1985, Vol. 3, pp. 724-729.
11. Jorgensen, F. R. A. and Zuiderwyk, M., *Journal of Physics E: Scientific Instrumentation*, 18:486-491 (1985).
12. Vardelle, M., Vardelle, A., Fauchais, P. and Boulos, M. I., *American Institute of Chemical Engineers Journal*, 29:236-243 (1983).
13. Fincke, J., Jeffery, C. L., and Englert, S. B., *Journal of Physics E: Scientific Instrumentation*, 21:367-370 (1988).
14. Kline, S. J. and McClintock, F. A., *Mechanical Engineering*, XX:3-8 (1953).