

DEVELOPMENT OF ADVANCED NDE ULTRASONIC EQUIPMENT

A.S. Birks and G.J. Posakony
Battelle Pacific Northwest Laboratories
Richland, WA 99352

ABSTRACT

Recent studies to determine the probability of detection of nondestructive examination methods by the Air Force indicate that these capabilities are severely limited. One of the factors contributing to the insufficiency of ultrasonic testing is related to a general lack of versatility and capability of commercial ultrasonic equipment. Inadequate instrument reliability, inconsistent components including transducers, and uncertain calibration standards further compromise the potential utility of this method.

Battelle Pacific Northwest Laboratories, under the sponsorship of the Manufacturing Technology Division of the Air Force Materials Laboratory, is developing an advanced ultrasonic nondestructive testing system directed at resolving these deficiencies. As a result, this program will establish a modular ultrasonic system specification that will prevent near term obsolescence by permitting the addition of new technology such as ARPA developments in the form of additional or replacement modules.

This paper will describe the Phase I and II tasks and objectives which are planned to establish an equipment specification, demonstrate initial prototype systems, and provide a procurement specification and technical manuals. Progress to date will be summarized.

INTRODUCTION

Recent studies¹ by the Air Force to determine the probability of detection of service induced flaws suggests that the capabilities of the ultrasonic examination method is limited to relatively large flaws. A current program² to determine acceptable performance ranges of transducers indicates that these components are highly variable and are suspected of being a major contributor to the unreliability of the examination method. In concert with similar on-going programs to provide more reliable NDE equipment to the USAF field and depot inspection activities and to make this equipment available to the manufacturers of engine/airframe components, a Manufacturing Technology Division program has been initiated under AFSC Contract F33615-78-C-5032 to establish specifications for more reliable, advanced ultrasonic NDE equipment.

The program will utilize current state-of-art opportunities as well as advanced concepts to attain the required performance improvements. The equipment will be established in a modular configuration that will permit future concepts to be added as they are developed and thereby prevent near term obsolescence. The advanced equipment concept is shown in Fig. 1. The functional areas to be addressed in this program includes the basic pulser-receiver elements used in the contemporary pulse-echo technique, the transducers, coaxial cable, electronic "gating" and recording methods, packaging, and system manuals.

Program Objectives - Specific areas of improvement have been identified as a result of reviewing previously conducted studies, surveys of USAFNDI shops and discussions with airframe and engine manufacturers. Typical areas of concern resulting from the survey of AFNDI shops are shown in Fig. 2. Specific areas of the instrumentation portion of the system where improvements will be made are:

1. Optimize pulser/driver
2. Establish transducer performance specs

3. Improve receiver noise figures, gain and bandwidth
4. Improve RF detector sensitivity and linearity
5. Optimize video display
6. Improve gating and recording
7. Optimize packaging for field use
8. Standardization of controls
9. Provide simplified calibration
10. Insure computer interfaceability

Improved technical training and operating maintenance manuals will be developed for the advanced ultrasonic equipment. These manuals will emphasize operation and performance clarity.

The ultrasonic system will then be documented as a final production procurement specification.

Current Activity - Several project teams have been making measurements and collecting data needed to establish performance specifications exemplifying these improvements. Specific areas of study include:

Evaluation of Current Equipment - One task group is evaluating current commercial UT equipment representative of that now in use by the Air Force and their suppliers. Seven instruments manufactured by four commercial UT equipment manufacturers have been selected for these tests. Each instrument will be evaluated at points in the system as shown in Fig. 3. A procedure has been developed to make these measurements in a specific and repeatable manner to provide accurate engineering data. The resulting data will be used to establish a baseline of current equipment performance. In addition, the information will provide a basis for the development of new specifications for the advanced ultrasonic equipment. The procedures used will be further utilized to evaluate the performance of newly manufactured equipment

TABLE 1.

TEST POINT	PARAMETERS							OTHER PERTINENT DATA		
	DAMPING CONTROL SETTING	LOAD	CENTER FREQUENCY (MHz)	-6 dB POINT (MHz)	+6 dB POINT (MHz)	OUTPUT VOLTS	DAMPING HALF CYCLES	RISE TIME 10% - 90% (NS)	DURATION 50% (NS)	
A EXCITATION PULSE	MIN	TRANSDUCER	7.0	1.0	7.0	—	—	80	300	
	MAX	TRANSDUCER	8.8	0.5	7.8	—	—	80	40	
B GENERATED ACOUSTIC ENERGY	MIN	TRANSDUCER	3.0	1.0	6.0	0.530	3			
	MAX	TRANSDUCER	6.26	4.5	7.0	0.280	4			
C RECEIVED SIGNAL	MIN	TRANSDUCER	6.0	2.25	8.0	0.130	8	42		
	MAX	TRANSDUCER	7.0	8.8	7.8	0.038	8	54		
D AMPLIFIED ACOUSTIC SIGNAL	MIN	TRANSDUCER	6.0	4.25	7.0	—	6			
	MAX	TRANSDUCER	8.8	6.0	7.2	—	3			

*LOAD IS A 12.8 mm (0.5 in) DIAMETER, UNTUNED LEAD METABORATE TRANSDUCER CONNECTED WITH A SIX FOOT (LONG 60) RG 86 COAXIAL CABLE

TEST OF INSTRUMENT AT 5.0 mhz

SURVEY OF AF BASES

COMMENT/SUGGESTION	KELLEY	DOVER	TRAVIS	MCLELLAN
PHYSICAL FACTORS				
LARGE SCOPE				
ADDITIONAL ALARM				
RAILS ON CABINET				
EXPLOSION-PROOF				
CONNECTOR INTEGRAL WITH S. U.				
ACCESS TO CONNECTORS				
LESS WEIGHT				
TILT ADJUST				
CABLE WIND-UP				
REMOTE CRT WITH SWEEP/GAIN CONTROLS AND GATE LIGHT				
DRIIP-PROOF				
CRT HOOD				
ELECTRONIC FACTORS				
HIGHER GAIN				
BRIGHT SCOPE				
BATTERY PROBLEMS				
NON-INTERCHANGEABLE				
TOO MANY CABLES ON ADAPTOR				
REMAINING TIME INDICATOR				
COMPUTERIZE CALIBRATION AND TECHNIQUE				
CHART OF EXAMINATIONS FOR PERMANENT RECORD				
COUPLANT MONITOR (PCI)				
BUILT-IN STANDARD				
VIDEO STORAGE				
THICKNESS READOUT				
ZBY OPERATION				
MAINTENANCE FACTORS				
AUTOMATIC TROUBLE DETECTOR				
BATTERY RUNS DOWN				
CONTROLS WEAR OUT				
SOLDER JOINTS INTERMITTENT OR BROKEN				
LOOSE TRANSISTORS				
S. U. CABLES FAIL				
HUMAN FACTORS				
GOOD TRAINING MANUAL				
GAIN CONTROLS (NOT ATTENUATION)				
BETTER BLUEPRINT TRAINING				
IMPROVED PRACTICAL TRAINING				
ALARM TOO IRRITATING				
UNIFORM CONTROL IDENTIFICATION				
FEWER CONTROLS				

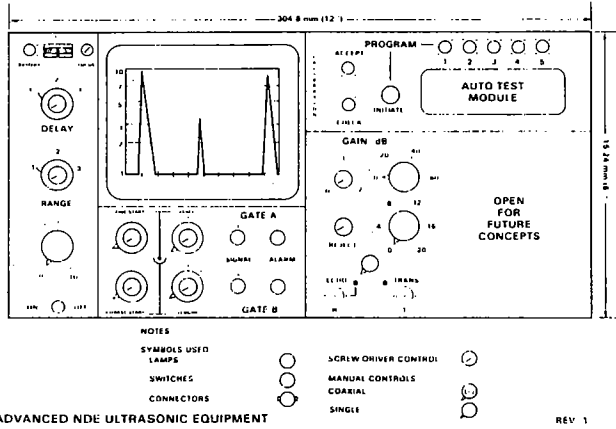

Figure 1. Concept of Advanced Ultrasonic System Control Panel

Figure 2. Current Problems and Recommendations for Advanced NDE Ultrasonic Equipment

and to assess the degree of performance deterioration of the production prototype equipment resulting from a full scale field evaluation.

Evaluation of Transducers - Transducer performance has been concurrently reviewed to determine the variabilities in relative insertion loss, electrical impedance, center frequency, bandwidth and damping.

Several prototypes have been manufactured utilizing current state-of-art developments. Transducers which have been effectively applied to turbine engine components manufactured in support of the near-net-shape program have provided excellent performance and appear to be prime candidates for the advanced systems. Others have been fabricated to arbitrary specifications to determine the parameters which must be specified to provide improved performance.

An intensive study has been conducted into the parameters of pulser/transducer impedance optimization in an effort to maximize acoustic output and minimize distortion. Several designs are now under study as possible candidates for the advanced equipment.

Calibrator Development - A method to permit the operator to conveniently and accurately evaluate the ultrasonic system's performance has been studied. The present concept will be developed at Battelle and incorporated as part of the system specification.

The calibrator envisioned would permit the transducer to be used for a specific application to be placed on the surface of a specifically designed test block. Sound transmitted into the block is detected by fixed wide band transducers located at the center of the incident sound beam. By selecting appropriate delays and gains, the incident pulse would be amplified, transmitted, and redirected back toward the transducer.

The returned pulse will then be viewed on the instrument's oscilloscope to determine if the system is operating within acceptable limits. The exact results of this test could be logged on test reports to indicate that the system had been checked and had maintained the correct level of operation through the test.

Breadboard Design - A breadboard demonstration system is concurrently being designed with the above activities. The breadboard will be built incorporating specific advancements to provide an interim model emulating the design concepts and performance established for the initial production prototype equipment. The breadboard system will

be used to demonstrate improvements of the advanced equipment to users and manufacturers that may be potential bidders for manufacture of six initial production prototype systems.

One of the features of the breadboard model shown in Fig. 4, is the use of a programmed standardization system. A microprocessor will adjust various system parameters to the requirements of a specific Technical Order (T.O.). These procedures describe the calibration adjustments required for testing a specific aircraft structural component. Specifically, the pulse transmission rate, receiver gain, sweep speed, gate interval and position, alarm and record levels will be controlled. To compensate for slight variations in transducers or electronic performance, a small amount of manual override over the nominal microprocessor selected adjustments will be provided. Similar instructions could be programmed for a variety of examinations providing subcomponents of the system are controlled by appropriate specifications.

New State-Of-Art Opportunities - One of the principal objectives of the advanced equipment program is to insure that the system will not be subject to near-term obsolescence. To attain this goal, the specifications must consider present and future applications in parameters describing the basic pulser/transducer/receiver, computer architecture and physical structure.

In response to this need, both current and new state-of-art concepts and opportunities are being evaluated. Those which have a good potential of upgrading ultrasonic equipment performance will be developed into breadboard models, as shown in Fig. 5, to determine the specific interface required for adaption. Areas such as digital signal processing, pattern recognition and signal improvement/noise suppression are typical candidates for future upgrading and are currently under study.

Progress to Date

Evaluation of Current Equipment - Data collected to date on the performance of current equipment indicates that:

1. A variety of pulse shapes are used by commercial equipment designers to excite the transducer to create the acoustic pulse burst. The most common pulse is a negative going pulse having a fast rise time and a gradual decay. In almost all cases, the pulser has been designed to work into a 50 Ω resistive load and little concern has been given to:
 - a. Matching the output impedance, consisting of the cable and transducer assembly, thereby eliminating or reducing standing waves and resulting distortions caused by reflections from the trans-

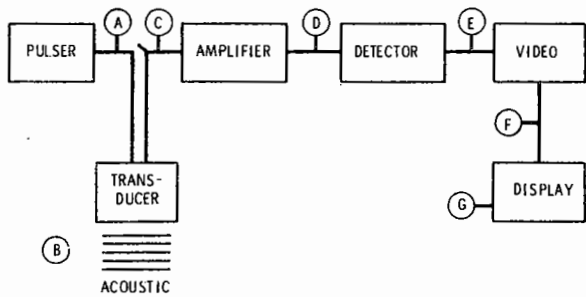

Figure 3. Ultrasonic Test Facility - Evaluating Advanced State-of-Art Concepts

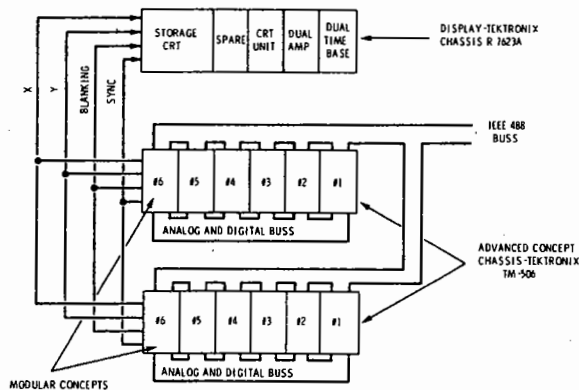

Figure 5. Ultrasonic Test Facility - Evaluating Advanced State-of-Art Concepts

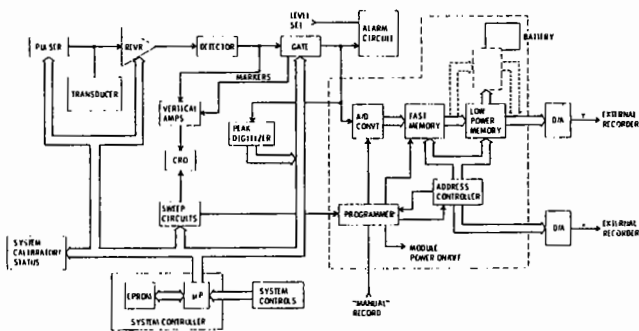

Figure 4. Advanced Ultrasonic Equipment - Breadboard Concept

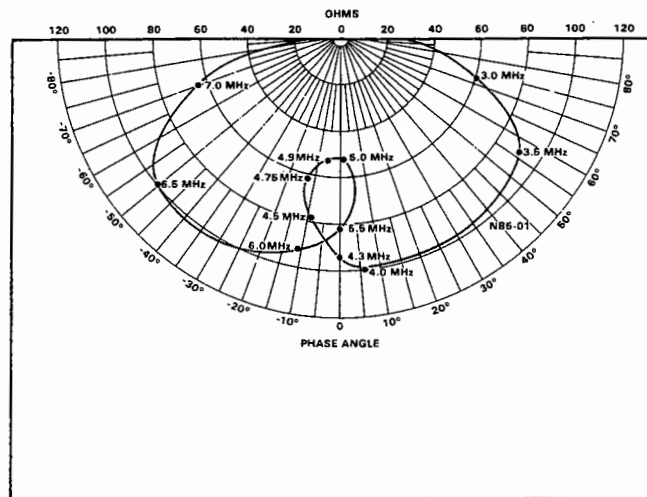

Figure 6. Transducer Complex Impedance as a Function of Frequency

ducer to cable mismatch.

- b. Properly terminating the input to effectively isolate the pulser impedance from the cable after the pulse has ceased
2. A test frequency shift has been measured on most equipment tested from point B to point D, Fig. 3. The frequency change measured on a typical instrument is shown in Table 1, where a variation of 3.0 MHz was observed as a result of merely manipulating the damping control from minimum to maximum setting. The most significant impact of this situation is that the actual center frequency and spectral content of the interrogating acoustic beam at point B varied from 3.0 MHz to 6.25 MHz, while the 6 dB bandwidth of the pulse changed from 1.0 to 6.0 MHz (min. damping) to 4.5 to 7.0 MHz (max. damping) as the signal passed through various stages of the instrument. If flaw characterization by pattern recognition or adaptive learning techniques are to be applied in the future, this uncontrolled variability must be controlled.
3. Commercial transducers evaluated to date appear to be of two basic types, highly damped with limited bandwidth or medium damped with tuned narrow band performance. Large impedance variations have been measured ranging from a few ohms to over 1000 ohms. The phase angle of the impedance can range from highly capacitive to inductive depending on the transducer design. Typical impedance plots in the form of a Smith chart are shown in Fig. 6. Actual frequency of operation is an approximation that nominally indicated, while bandwidths vary widely.

Transducers for future equipment will have to perform in a more predictable manner. However, the method and procedure of measuring the performance of transducers must be simultaneously developed to provide a common ground for evaluation of specified performance. An arbitrary procedure is being established as part of this study.

SUMMARY

The need to resolve the unpredictable performance of ultrasonic nondestructive testing equipment has been treated by the user as a specific and monotonic value in determining examination repeatability, sensitivity and detectability. Reliable flaw characterization using current commercial equipment appears to be unattainable unless tighter equipment specifications are invoked.

The specific contributors to unacceptable

performance are not obvious and perhaps this is the reason they have been retained in current equipment designs. The results of evaluating current commercial equipment indicates that the following areas are the most serious:

1. The availability of transducers that have unspecified wide variations in impedance values and phase angles.
2. The presence of uncalibrated and non-uniform controls which when reset create unpredictable testing parameters.
3. The creation of harmonics and phase distortions by improperly terminating cables and transducer loads.
4. The use of random lengths and types of coaxial cables.
5. Saturation in the receiver amplifier creating response variations that are difficult to relate to the causative source.
6. Noise inherent to the equipment design or other sources within the system that requires the use of "reject" or other noise reduction schemes.

The current program will provide significantly advanced NDE ultrasonic equipment, correctly designed for the user and manufactured to perform in an accurate and predictable manner. The implementation of this equipment by the Air Force and its suppliers will result in improved probability of detection of defects by the ultrasonic nondestructive examination method.

REFERENCES

1. W.H. Lewis, Lockheed Georgia Company, "Non-destructive Inspection Reliability Program"-Workshop Notes, USAF-AFLC Contract F41608-73-D-2850-0038, August, 1978.
2. V.D. Smith, C.M. Teller, R.K. Swanson, Southwest Research Institute, "Engineering Services to Determine Acceptance Levels of Ultrasonic Transducers for Nondestructive Testing", Final Engineering Report, USAF Contract F41608-77-C-1381, June, 1978.

SUMMARY DISCUSSION
(A. S. Birks)

Don Thompson (Science Center): Could you describe your calibrator again?

Al Birks: The calibrator we have developed at this point is a delay line, a block of solid piece of material, on which the transducer selected for a particular application would be placed. The sound beam would propagate through the block where the signal would be detected by a wide bandwidth transducer located on the opposite side. The signal would go through an amplifier and a delay line, whose amplification and delay time would be set in accordance with the required transducer. This is required to compensate for the beam geometry which is dependent on the frequency and size of the transducer. This signal is then repropagated back toward the transducer. The returning signal will then be amplified by the instrument's receiver--now you're back into the main instrument--and displayed on the oscilloscope screen. The program could be set up to call for a certain amplitude of signal. The presence of this appropriate signal, as required by the program, would be evaluated by a decision algorithm in the program and advise the technician to proceed with his test. It's kind of a check-out. It's not a true calibration.

Chris Fortunko (Science Center): Could you tell us what the improvements will be to the transmitter and circuitry in this instrument over the current instrumentation?

Al Birks: The improvements are multifold. First of all, we are looking at this present time at a spike pulse, which appears to be a very good selection. We have also looked at other forms of excitation, mainly a square wave, which appears to have very good possibilities. It looks like there may be approximately five db more gain available here over the spike pulse, but it may require quite a bit of temporal adjustment to attain this gain.

Chris Fortunko: The problem with the spike pulse is that it has a lot of energy to get the high frequency. The way you generate it now is by means of an avalanche device, such as a transistor or SCR, where biasing is very sensitive to thermal variations and load characteristics.

Al Birks: You mean like the impedance? That's another problem. The impedance of the cable and terminating load of the transducer is quite a factor in the system. A mismatch introduces quite a bit of standing wave distortion. We're looking at the impedance-matching problems both at the output of the pulse, the receiver input isolation, and transducer load to reduce distortion in the reflected wave coming back from the transducer.

Bob Addison (Science Center): Just a point of clarification. When you were measuring the peak of the frequency response for those variety of pulses, what measurement was that? I wasn't quite clear what you were measuring.

Al Birks: You mean the amplitude?

Bob Addison: You were measuring the peak amp. What frequency did it peak out? The center frequency? The first pulser characteristics? Then you have two dampening control settings, one is two and one is 5.8. What were you looking at there? I just wasn't sure. What are you measuring?

Al Birks: We are measuring the center frequency.

Bob Addison: The center frequency of what?

Al Birks: The electrical pulse which is applied to the crystal or the load. This is the spectrum of the pulse that is applied to the transducer and the maximum response of that spectrum has been labeled "Peak Frequency".

Bob Addison: Fine.

Al Birks: At this time we do not know what good this information is going to be to us, but, obviously, if you don't have the frequency contained in the electrical pulse that is activating the transducer, it's rather difficult to expect to get the acoustic energy at that frequency out later. That's what I mean, this specific interrelationship has not yet been developed--it has been quite interesting observing these variations which form a base line and a basis for preliminary specifications. We will have to convert these specifications into

(continued)

A. Birks (continued discussion)

a production procurement document for the Air Force and procure improved equipment. Therefore, we have got to get a thorough understanding of how current equipment performs.

Unidentified Speaker: Did this instrument have a spike pulse on the transmitter, or was it a switch sort of a thing that went down sharply and then came back?

Al Birks: It was spiked.

Unidentified Speaker: Avalanche-type pulse?

Al Birks: I believe it was, yes.

Roy Buckrop (U.S. Army Armament Matl. Readiness Command): Al, you said you might talk about a logarithmic readout as compared to a linear. Is this a move and an attempt to be able to discriminate more finitely between the background and the usable signal? I'm referring back to our nonmetallic inclusion application where we used computer banks in order to provide signal discrimination out of the "grass" or background noise signals. Will a logarithm help you do this?

Al Birks: It really won't help you. It will amplify the low level signals and actually make your noise a more prominent feature of the display. A problem in the Air Force operation is that they use a lot of "rejects" to remove these unwanted signals. I've seen some operators use an undesirable amount of "rejects" where the dial would be turned to the 75 percent "ON" position. You know, with all the concern about vertical linearity and other instrument performance, we created a monster here where gain and distortion are running rampant without much concern of the compromises to reproducibility or detectability.

Roy Buckrop: So you're still going to make the discriminating factor operator oriented, not trying to put anything in the instrument's gain to remove the operator's characteristics and provide a more finite discrimination of signal information as compared to the background noise? Is the gating going to be adjusted any closer to that signal-to-noise relationship?

Al Birks: Roy, we hope that by making the signal a less-distorted signal and balancing all of the electronics throughout the system, we will get a much cleaner signal. Hopefully then the noise will be minimized and the "noise" that remains is truly representative of acoustic information rather than electronic distortion.

#